

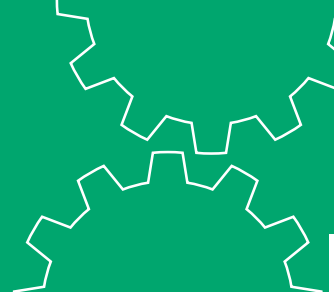

# Worm Gears



- Spur Gears
- Helical Gears
- Internal Gears
- Racks
- CP Racks & Pinions
- Miter Gears
- Bevel Gears
- Screw Gears
- Worm Gears**
- Gearboxes
- Other Products

<b>KWGD/L/KWGDLS</b> Duplex Worms <b>NEW</b> <b>S</b>  Material: SCM440 m1.5-6 Page 406	<b>AGDL</b> Duplex Worm Wheels Reduction Ratio 20-60 <b>NEW</b> <b>M</b> <b>S</b>  Material: CAC702(A&BC2) m1.5-6 Page 406	<b>KWG</b> Ground Worm Shafts  Material: SCM440 m0.5-6 Page 416	<b>AG</b> Worm Wheels Reduction Ratio 10-60 <b>J</b>  Material: CAC702(A&BC2) m0.5-1.5 Page 416	<b>AGF</b> Worm Wheels Reduction Ratio 10-60  Material: CAC702(A & BC2) m2-6 Page 420	<b>SWG</b> Ground Worms  Material: S45C m1-6 Page 426	<b>AG</b> Worm Wheels Reduction Ratio 10-60 <b>J</b> <b>M</b> <b>S</b>  Material: CAC702(A&BC2) m1-6 Page 426	<b>SW</b> Worms <b>NEW</b> <b>J</b> <b>M</b> <b>S</b>  Material: S45C m0.5-10 Page 434
<b>BG</b> Worm Wheels Reduction Ratio 10-60 <b>J</b> <b>M</b>  Material: CAC502(PBC2) m0.5-6 Page 434	<b>CG</b> Worm Wheels Reduction Ratio 10-12 <b>NEW</b> <b>J</b> <b>S</b> <b>M</b>  Material: FC200 m1-10 Page 436	<b>SUW</b> Stainless Steel Worms  Material: SUS303 m0.5-3 Page 454	<b>PG</b> Worm Wheels Reduction Ratio 10-60 <b>J</b>  Material: MC901 m0.5-3 Page 454				

**M** Includes Made to Order

## Catalog Number of KHK Stock Gears

The Catalog Number for KHK stock gears is based on the simple formula listed below. Please order KHK gears by specifying the Catalog Numbers.

(Example) Worm Gear Pair

Worms

**K W G DL 2 - R1**

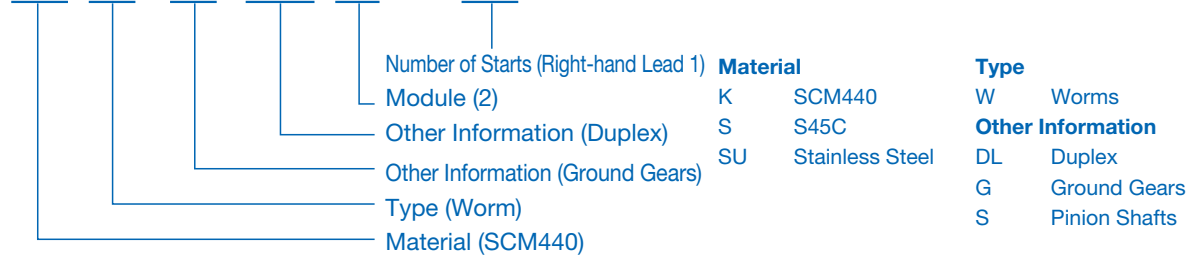

Worm Wheels

**A G DL 2 - 20 R1**

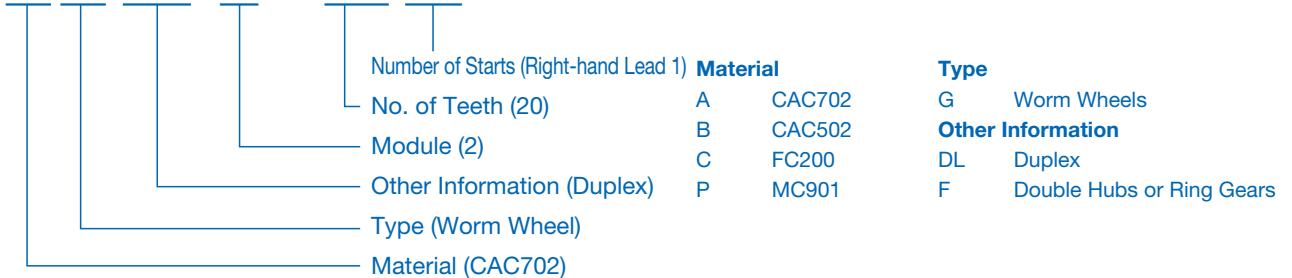



## Features



KHK stock worm gears are available in modules 0.5 to 6, reduction ratios of 1/10 to 1/120, and a wide range of materials and shapes. Duplex worm gears with adjustable backlash and highly accurate rotation are also available. The following table lists the main features.

Type	Catalog Number	Module	Number of Starts or Reduction Ratio	Material <small>Old JIS in parentheses</small>	Heat treatment	Tooth Surface Finish	Precision Grade <small>KHK W 001 KHK W 002 Note 2</small>	Features	
Duplex Worm Gears	Worms	<b>KWGDL</b>	2~4	Single Start	SCM440	Thermal refined, gear teeth induction hardened	Ground	1	Duplex worms that have been tempered, hardened and ground that has excellent accuracy, strength and abrasion resistance. Secondary operations can be given except for the teeth. Moving it in axial direction will adjust the backlash.
	Worms	<b>KWGDL S</b>	1.5~6	Single Start	SCM440	Thermal refined, gear teeth induction hardened	Ground	1	Duplex worms with shafts that have been tempered, hardened and ground that has excellent accuracy, strength and abrasion resistance. Secondary operations can be given except for the teeth. Moving it in axial direction will adjust the backlash.
	Wheels	<b>AGDL</b>	1.5~6	20~60	CAC702 (A & BC2)	—	Cut	1	Duplex worm wheels made of aluminum bronze with excellent accuracy and a good balance between machinability and wear resistance. Used in combination with KWGDL or KWGDL S.
Worm Gears	Worms	<b>KWG</b>	0.5~6	Single or Double Start	SCM440	Thermal refined, gear teeth induction hardened	Ground	2	Worms with shafts that have been tempered, hardened and ground that has excellent accuracy, strength and abrasion resistance. Secondary operations can be performed except for the teeth.
	Wheels	<b>AGF</b> NOTE 1	2~6	10~60	CAC702 (A & BC2)	—	Cut	2	Worm wheels made of aluminum bronze with a good balance between machinability and wear resistance. Used in combination with KWG.
	Worms	<b>SWG</b>	1~6	Single or Double Start	S45C	Gear teeth induction hardened	Ground	2	Worms that have been hardened and ground with a good balance of accuracy, wear resistance and cost. Secondary operations are possible except for the teeth.
	Wheels	<b>AG</b> NOTE 1	0.5~6	10~60	CAC702 (A & BC2)	—	Cut	2	Worm wheels made of aluminum bronze with a good balance between machinability and wear resistance. Used in combination with SWG. Note 1
	Worms	<b>SW</b>	0.5~10	Single or Double Start	S45C	—	Cut (Rolling)	4	Many lineups are available at a low price and excellent usability.
	Worms	<b>SUW</b>	0.5~3	Single or Double Start	SUS303	—	Cut	4	Stainless steel worms with rust resistance.
	Wheels	<b>BG</b>	0.5~6	10~60	CAC502 (PBC2)	—	Cut	4	Worm wheels made of phosphorus bronze with excellent wear resistance. Used in combination with SW and SUW.
	Wheels	<b>CG</b>	1~10	10~120	FC200	—	Cut	4	Cast iron worm wheels that are inexpensive and suitable for light loads. Used in combination with SW and SUW.
	Wheels	<b>PG</b>	0.5~3	10~60	MC901	—	Cut	5	Worm wheels made of MC nylon. Can be used with no lubrication. Used in combination with SW and SUW.

[Note 1] FC200 is the material for the hubs of AGF and AG worm wheels. The AG worm wheels are normally combined with the SWG worms, but are also compatible with the KWG worms with module 1.5 and below.

[Note 2] The precision grade of KHK stock worm gears controls the product quality based on the KHK standards. Please see "Precision of Worm Gears" on Page 400 in the Selection Hints section for details.

## High-precision ground gear worms are available.

We use screw grinding machines manufactured by DRAKE, USA, to manufacture high-precision ground worms of module 0.5 to 8.



CNC Screw Grinding Machine (TE-LM200)

Worm ground gear machining range	
Maximum gear accuracy	KHK Grade 1
Maximum module	m8
Maximum nominal lead angle	±35°
Maximum outer diameter	φ 200mm
Maximum length	330mm

## Application Examples



Worm gears are used in a wide range of fields, such as positioning mechanisms and reversing mechanisms.

### ■ Wiper Drive Device



Image: Provided by PK Design

Worm gear used for the oscillating mechanism of wipers

### ■ Yaesu Steam Kettle



SW worm and CG worm wheel used for rotating large pans

### ■ Masdac Food Filling Device



KWGD Duplex Worm Wheels and AGDL Worm Wheels used for indexing and driving, for accurate filling of a fixed amount of ingredients

### ■ Gonio Stage Design Example

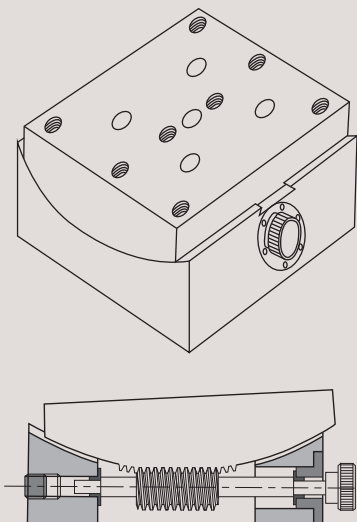

Worm gear used for rotating tables (design example)

### ■ Worm Jack

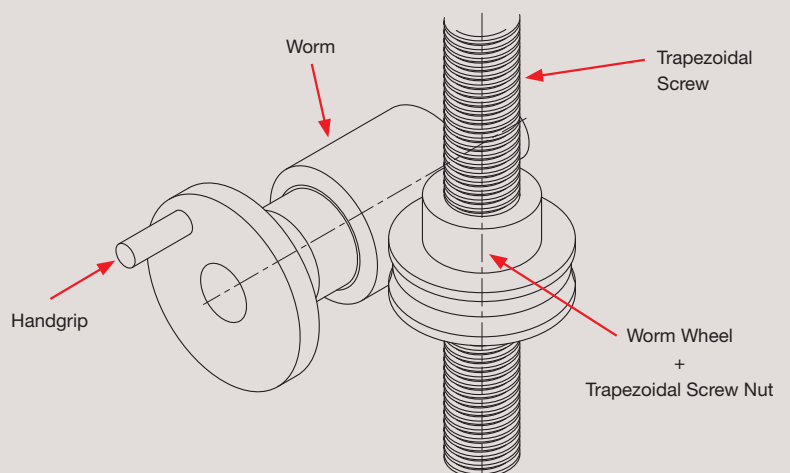



## Selection Hints



Please select the most suitable products by carefully considering the characteristics of items and contents of the product tables. It is also important to read all applicable "CAUTION" notes shown below before the final selection.

### 1. Caution in Selecting the Mating Gears

Worm gears are available in right-hand helix and left-hand helix. Worms and worm wheels of the same helix direction are combined. However, combination may not be possible due to the difference in the number of starts of the worm and the difference in pitch being normal and transverse (axial direction). Below is the Mating Helical Gear Selection Chart for KHK worm gears.

#### Mating Worm Wheel Selection Chart

Worms		KWGDL KWGDLS	KWG		SWG		SW				SUW	
Mating Wheel Note 1	Hand Number of Starts	R1	R1	R2	R1	R2	R1	R2	L1	L2	R1	R2
AGDL	R1	○										
AG0.5~1.5 AGF	R1		○									
	R2			○								
AG	R1				○							
	R2					○						
BG	R1						○					○
	R2							○				
	L1								○			
	L2									○		
CG	R1							○				○
	R2								○			
	L1									○		
	L2										○	
PG	R1						○					○
	R2							○				

[Note 1] The mating wheel must have the same module as the worm.

### Helix direction of worm gears

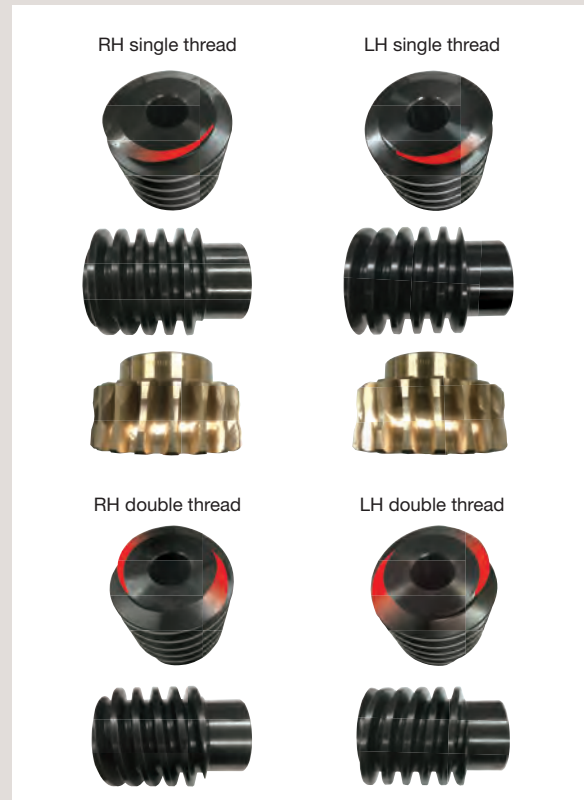

### 2. Caution in Selecting Gears Based on Gear Strength

The gear strength values shown in the product pages were computed by assuming the application environment in the table below. Therefore, they should be used as reference only. We recommend that each user computes their own values by applying the actual usage conditions.

#### Calculation of Surface Durability

#### Calculation of Bending Strength of Gears

Item	Catalog Number	KWGDL/KWGDLS/AGDL KWG/AGF, SWG/AG	SW/BG	SW/CG	SUW/PG
Formula	NOTE 1	Formula of cylindrical worm gear strength (JGMA405-01)			The Lewis formula
Lubricating Oil		Lubricating oil with appropriate viscosity that contains extreme pressure additive for gears			Allowable bending stress (kgf/mm <sup>2</sup> )  1.15 (40°C with No Lubrication)
Lubrication Method		Oil Bath Lubrication (Oil Bath)			
Startup Status		The starting torque is 200% or less of the rated torque, and the number of starts per hour is under 2.			
Expected Service Life		26,000 hours			
Impact from motor		Uniform load			
Impact from load		Uniform load			
Allowable Stress Coefficient Sclim		0.67	0.70	0.42	

[NOTE 1] The gear strength formula is based on JGMA (Japanese Gear Manufacturers Association) specifications, "MC Nylon Technical Data" by Mitsubishi Chemical Advanced Materials. The units for the rotational speed (rpm) and the stress (kgf/mm<sup>2</sup>) are adjusted to the units needed in the formula.

When selecting KHK standard gears, glance over the Product Precautions on page 402 and Cautions on Performing Secondary Operations on each page.

- Products not listed in this catalog or materials, modules, number of teeth and the like not listed in the dimensional tables can be manufactured as custom items. Please see Page 26 for more details about custom-made orders.
- The color and shape of the product images listed on the dimension table page of each product may differ from the actual product. Be sure to confirm the shape in the dimension table before selection.
- The details (specifications, dimensions, etc.) listed in the catalog may be changed without prior notice. Changes are announced on the KHK website.

Website URL : <https://khkgears.net/new/>

Overseas Sales Department: Phone : +81-48-254-1744 Fax: +81-48-254-1765 E-mail: [info@khkgears.net](mailto:info@khkgears.net)

# The most important factor in selecting gears is the gear strength.

## Step 1

Use the calculation of load torque applied to the gear and the sliding speed to determine the worm gear suitable for the purpose.

### Maximum allowable sliding speed due to friction

The maximum allowable sliding speed of each worm gear is shown in the table below. Sliding speed should be calculated when making a selection.

Sliding speed  $v_s$  (m/s)

$$v_s = \frac{dn}{19100 \cos \gamma}$$

$d$  : Worm pitch dia.  
 $n$  : Worm rotational speed  
 $\gamma$  : Worm nominal lead angle

Catalog Number	Maximum allowable sliding speed (m/s)
<b>AGDL</b>	* 15
<b>AGF</b>	* 15
<b>AG</b>	* 15
<b>BG</b>	* 10
<b>CG</b>	* 2.5
<b>PG</b>	1 (No Lubrication)

\* From JGMA405-01

### Surface durability

Calculated values of the strength at which the worm wheel teeth do not wear due to surface fatigue damage. If the tooth surface is not sufficiently lubricated, the surface may be damaged even if the load is less than the tooth surface durability.

## Step 2

Select provisionally from the allowable torque table in this catalog based on the load torque.

### For provisional selection from this catalog

Catalog Number	Reduction ratio	Transverse module	No. of teeth	No. of starts	Lead angle	Direction	Allowable torque (N·m)						Backlash (mm)	
							30	100	300	600	900	1200		1800
AG0.5-20R1	20	20	1	3°11'	R	9.5	0.52	0.44	0.36	0.30	0.26	0.24	0.21	0.02~0.12
AG0.5-20R2	10	20	2	6°20'	R	9.5	0.51	0.42	0.33	0.27	0.24	0.22	0.19	
AG0.5-30R1	30	30	1	3°11'	R	12	1.09	0.94	0.77	0.65	0.58	0.53	0.48	
AG0.5-40R1	40	40	1	3°11'	R	14.5	1.86	1.60	1.34	1.15	1.02	0.94	0.84	
AG0.5-50R1	50	50	1	3°11'	R	17	2.82	2.42	2.05	1.77	1.58	1.46	1.30	
AG0.5-60R1	60	60	1	3°11'	R	19.5	3.94	3.41	2.89	2.50	2.26	2.08	1.87	
AG0.8-20R1	20	20	1	3°49'	R	4	1.78	1.50	1.21	1.00	0.88	0.82	0.71	0.02~0.12
AG0.8-20R2	10	20	2	7°36'	R	4	1.76	1.44	1.11	0.91	0.80	0.74	0.63	
AG0.8-30R1	30	30	1	3°49'	R	8	3.77	3.21	2.62	2.20	1.96	1.81	1.61	
AG0.8-30R2	15	30	2	7°36'	R	8	3.75	3.14	2.46	2.02	1.80	1.65	1.45	
AG0.8-40R1	40	40	1	3°49'	R	2	6.45	5.49	4.55	3.87	3.46	3.19	2.83	
AG0.8-50R1	50	50	1	3°49'	R	86	9.75	8.31	6.94	5.94	5.34	4.96	4.38	
AG0.8-60R1	60	60	1	3°49'	R	30	13.6	11.7	9.77	8.39	7.63	7.05	6.27	

## Step 3

Calculate the strength under the actual usage conditions.

Calculate the strength formally using the various gear strength formulas. We recommend using the simple strength calculation available on our website.

### Use the strength calculation function on our website.



### 3. Cautions on Selecting Racks By Precision

The precision standards of KHK stock worm gears are established by us. Check the precision table below.

#### ① Worm Precision (KHK W 001)

For the pitch error and lead error of the worm, the allowable values of 1 to 4 grades are set for each module with reference to the JIS standards. The lead error is the allowable value of the tooth trace error in one lead.

#### ■ Worm Precision KHK W 001 (Unit: $\mu\text{m}$ )

Grade	Error	Module				
		Over m0.4 to 1	Over m1 to 1.6	Over m1.6 to 2.5	Over m2.5 to 4	Over m4 to 6
1	Pitch Error	8	12	16	20	25
	Lead Error	7	9	11	13	16
2	Pitch Error	12	16	20	24	29
	Lead Error	15	18	21	25	28
3	Pitch Error	16	23	30	37	50
	Lead Error	20	23	27	33	37
4	Pitch Error	20	30	40	50	70
	Lead Error	30	32	38	46	52

#### ② Worm Wheel Accuracy (KHK W 002)

Our precision grades for pitch errors are established by referring to old JIS Standards. The precision grades are set from 1 to 5, in accordance with the tolerance of a single pitch error (S.P.E.), adjacent tooth-to-tooth error (T.T.E.), and the total composite error (T.C.E.) for each module and pitch diameter.

#### ■ Worm Wheel Accuracy KHK W 002

Unit:  $\mu\text{m}$

Grade	Error	Over m0.4 to 1					Over m1 to 1.6					Over m1.6 to 2.5					Over m2.5 to 4					Over m4 to 6				
		Pitch dia. (mm)																								
		6 to 12	12 to 25	25 to 50	51 to 100	100 to 200	12 to 25	25 to 50	51 to 100	100 to 200	200 to 400	12 to 25	25 to 50	51 to 100	100 to 200	200 to 400	25 to 50	51 to 100	100 to 200	200 to 400	400 to 800	25 to 50	51 to 100	100 to 200	200 to 400	400 to 800
1	Single Pitch Error	5	6	7	7	9	6	7	8	9	10	7	7	8	9	11	8	9	10	11	13	9	10	11	13	14
	Total Pitch Error	21	24	26	30	34	25	28	31	35	41	27	30	33	37	43	33	36	40	46	53	37	40	45	50	57
2	Single Pitch Error	8	8	9	10	12	9	10	11	12	14	9	10	12	13	15	11	13	14	16	18	13	14	16	18	20
	Total Pitch Error	30	33	37	42	48	35	39	44	50	57	38	42	46	52	60	46	51	57	64	74	52	57	63	71	80
3	Single Pitch Error	11	12	13	15	17	12	14	16	18	20	13	15	16	19	21	16	18	20	23	26	19	20	22	25	29
	Total Pitch Error	43	47	53	60	68	50	55	62	71	81	53	59	66	74	85	65	72	81	91	105	74	81	90	100	115
4	Single Pitch Error	15	17	19	21	24	18	19	22	25	29	19	21	23	26	30	23	25	28	32	37	26	28	32	35	40
	Total Pitch Error	60	66	74	83	95	70	77	87	99	115	75	83	92	105	120	91	100	115	130	145	105	115	125	140	160
5	Single Pitch Error	21	24	26	30	34	25	28	31	35	41	27	30	33	37	43	33	36	40	46	53	37	40	45	50	57
	Total Pitch Error	86	94	105	120	135	100	110	125	140	165	105	120	130	150	170	130	145	160	185	210	150	160	180	200	230

#### ③ Total Length Tolerance for Worm Gears

#### ■ Total Length Tolerance for Worms

Series	Total Length (mm)	Tolerance
KWGDL	Uniform	0 -0.10
	100 or less	0 -0.15
SWG SW SUW	Over 100 200 or less	0 -0.20
	Uniform	Normal Tolerance

#### ■ Total Length Tolerance for Worm Wheels

Total Length (mm)	Tolerance
30 or less	0 -0.10
31 to 100	0 -0.15
Over 100	0 -0.20

[NOTE] PG Plastic Wheels are excluded.

## 4. Cautions in Selecting Worm Gears Based on Efficiency

The transmission efficiency of worm gears varies slightly depending on the assembled state, lubricating oil and the like, but the transmission efficiency (excludes bearing loss and loss of lubricating oil due to stirring) of worm wheels when driven from the worm is approximately 30% to 90%. The transmission efficiency table of the KHK stock worm gears is shown below (reference values).

### ① Efficiency of Various Worms

#### ■ KWGDL/KWGDLS/AGDL Worm Gear Efficiency (%)

(rpm = Worm Rotational Speed)

Worm Rotational Speed Catalog Number	100	300	600	900	1200	1800
<b>KWGDLS1.5-R1</b>	35	42	47	51	53	57
<b>KWGD2-R1</b>	38	45	51	55	56	61
<b>KWGD2.5-R1</b>	40	48	54	57	60	63
<b>KWGD3-R1</b>	41	49	55	58	62	65
<b>KWGD3.5-R1</b>	42	50	56	61	62	65
<b>KWGD4-R1</b>	42	51	56	61	63	67

#### ■ KWG/AG/AGF Worm Gear Efficiency (%)

(rpm = Worm Rotational Speed)

Worm Rotational Speed Catalog Number	100	300	600	900	1200	1800
<b>KWG0.5-R1</b>	30	34	38	41	43	46
<b>KWG0.8-R1</b>	35	40	44	47	49	53
<b>KWG1-R1</b>	34	40	45	48	51	54
<b>KWG1.5-R1</b>	35	42	47	51	53	57
<b>KWG2-R1</b>	45	51	56	60	62	65
<b>KWG2.5-R1</b>	44	51	57	61	62	67
<b>KWG3-R1</b>	44	52	58	61	64	67
<b>KWG4-R1</b>	50	58	64	66	70	72
<b>KWG5-R1</b>	51	60	66	69	71	73
<b>KWG6-R1</b>	53	61	66	70	72	75
<b>KWG0.5-R2</b>	46	50	54	58	60	63
<b>KWG0.8-R2</b>	51	56	61	64	66	69
<b>KWG1-R2</b>	51	56	62	64	67	70
<b>KWG1.5-R2</b>	52	59	64	67	69	73
<b>KWG2-R2</b>	61	67	71	74	76	78
<b>KWG2.5-R2</b>	60	67	72	75	76	80
<b>KWG3-R2</b>	61	68	73	75	78	80
<b>KWG4-R2</b>	66	73	77	79	82	84

#### ■ SWG/AG Worm Gear Efficiency (%)

(rpm = Worm Rotational Speed)

Worm Rotational Speed Catalog Number	100	300	600	900	1200	1800
<b>SWG1-R1</b>	34	40	45	48	51	54
<b>SWG1.5-R1</b>	35	42	47	51	53	57
<b>SWG2-R1</b>	38	45	51	55	56	61
<b>SWG2.5-R1</b>	40	48	54	57	60	63
<b>SWG3-R1</b>	41	49	55	58	62	65
<b>SWG4-R1</b>	42	51	56	61	63	67
<b>SWG5-R1</b>	46	54	60	64	66	70
<b>SWG6-R1</b>	48	57	64	66	68	73
<b>SWG1-R2</b>	51	56	62	64	67	70
<b>SWG1.5-R2</b>	52	59	64	67	69	73
<b>SWG2-R2</b>	55	62	67	70	72	75
<b>SWG2.5-R2</b>	57	64	69	72	75	77
<b>SWG3-R2</b>	58	66	71	73	76	78
<b>SWG4-R2</b>	59	67	72	75	77	80
<b>SWG5-R2</b>	62	70	75	78	79	82
<b>SWG6-R2</b>	65	72	77	80	81	84

#### ■ SW, SUW/CG, BG, PG Worm Gear Efficiency

The values shown in the table below are estimates and may vary slightly according to conditions such as assembled state, load, lubrication and rotation speed.

Catalog Number	Number of Starts	Efficiency (%)
<b>SW/SUW</b>	1 Start	30~50%
	2 Starts	50~60%

### ② Self-locking of worm gears

The state of the worm not being able to be rotated from the worm wheel is called self-locking. Self-locking happens due to the worm gear's material, lead angle, machining accuracy, bearing type, lubricating oil, etc.

There are various factors, so self-lock is not always determined only by the lead angle, but usually a single-start worm self-locks at a lead angle of 4° or less. If complete reverse prevention is required, use another braking mechanism or the like in combination.

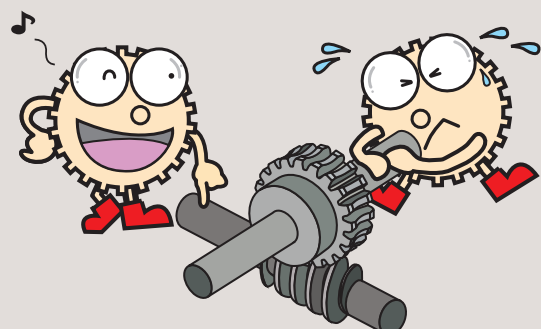



## Product Precautions



### Worm Common Notes

#### [Caution on Product Characteristics]

- (1) These worm gears produce axial thrust forces. Please see page 404 for more details.
- (2) Keyways are made according to JIS B1301 standards, Js9 tolerance. Also note that keyway tooth position alignment is not performed.
- (3) For products having a tapped hole, a set screw is included.
- (4) For bores of  $\phi$  4 or below, the bore tolerance is H8. As well, the tolerance is H8 for  $\phi$  5 or  $\phi$  6 bores with hole length (total length) 3x the bore or more.
- (5) For hole lengths 3.5x the bore or more, the hole center is out of H7 tolerance.

#### [J Series]

- (1) Black oxide is not re-applied to parts undergoing secondary operations.

### Worm Wheel Common Notes

#### [Caution on Product Characteristics]

- (1) The allowable torque shown in the table are calculated values according to the assumed usage conditions. Please see page 398 for more details.
- (2) Variations in temperature or humidity can cause dimensional changes in plastic gears, including tooth diameter, bore, and backlash. The accuracy and tolerances shown in the catalog are values obtained when machining is performed.
- (3) For bores of  $\phi$  4 or below, the bore tolerance is H8. As well, the tolerance is H8 for  $\phi$  5 or  $\phi$  6 bores with hole length (total length) 3x the bore or more.
- (4) These worm gears produce axial thrust forces. Please see page 404 for more details.
- (5) Some products have a slight gap in the casted section, but this does not affect the holding strength.
- (6) Keyways are made according to JIS B1301 standards, Js9 tolerance. Also note that keyway tooth position alignment is not performed.
- (7) For products having a tapped hole, a set screw is included.
- (8) FC200's tensile strength ( $200\text{N}/\text{mm}^2$ ) is derived from test specimens and does not represent that of the boss.

#### [Caution on Secondary Operations]

- (1) Because it affects the cast portion, there is no additional modification other than to the boss part.
- (2) As the worm wheel is casted, bubbles may form inside the material.  
If the air bubbles found in secondary operations are problematic, contact the supplier.

#### [J Series]

- (1) Certain products which would otherwise have a very long tapped hole are counterbored. For details, please see the KHK website.
- (2) For bores over  $\phi$  50, the bore tolerance is H8.

## Tapped Holes in Semi-Custom Standard Products

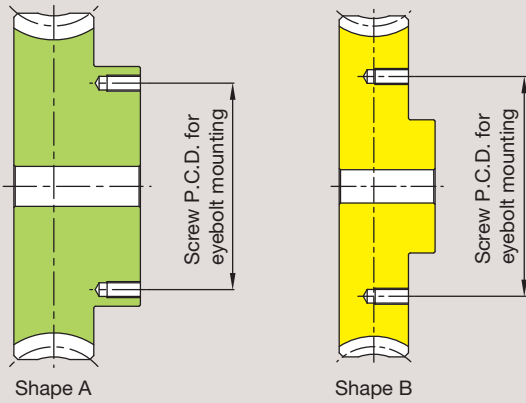

Catalog Number	Shape	Screw P.C.D. for eyebolt mounting
AGDL5-50R1S	A	205
AGDL5-60R1S	A	255
AGDL6-40R1S	A	195
AGDL6-50R1S	A	255
AGDL6-60R1S	A	315

Catalog Number	Shape	Screw P.C.D. for eyebolt mounting
CG5-50L1S	B	155
CG5-60L1S	B	165
CG6-40L1S	B	165
CG6-50L1S	B	165
CG6-60L1S	B	185
CG8-30R1S	A	155
CG8-40R1S	A	195
CG8-50R1S	A	215
CG10-20R1S	A	140
CG10-30R1S	A	215
CG10-40R1S	A	255



## Application Hints



In order to use KHK stock worm gears safely, carefully read the Application Hints before proceeding.

If there are questions or you require clarifications, please contact our technical department or your nearest distributor. E-mail: info@khkgears.net

Please read "Cautions on Performing Secondary Operations" below when performing modifications and/or secondary operations for safety concerns.

### 1. Cautions on Handling

- ① KHK products are packaged one by one to prevent scratches and dents, but if you find issues such as rust, scratches, or dents when the product is removed from the box after purchase, please contact the supplier.
- ② Depending on the handling method, the product may become deformed or damaged. Resin gears and ring gears deform particularly easily, so please handle with care.

### 2. Caution on Performing Secondary Operations

- ① Gears are machined based on the ground section of the hole or shaft. If machining, it is important to pay special attention to locating the center in order to avoid runout. (Fig.1)  
If it is too difficult to do for small bores, the alternative is to use one spot on the bore and the runout of the hub end surface.

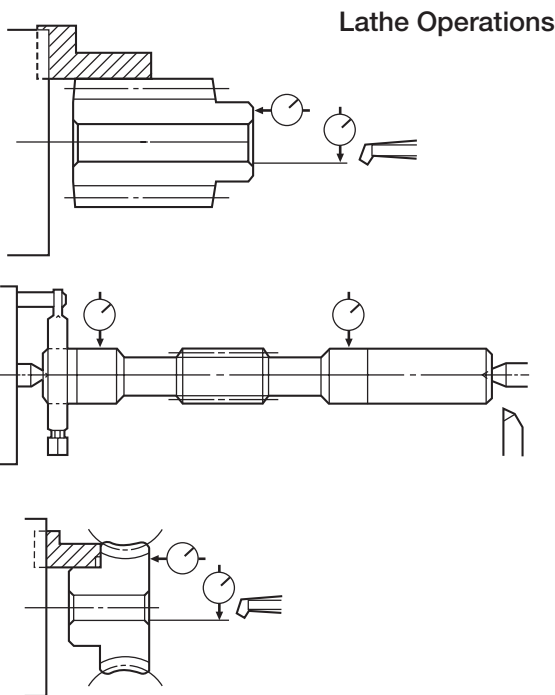

If reworking using scroll chucks, we recommend the use of new or rebores jaws for improved precision.

Fig. 1

- ② If enlarging the bore diameter, the wall strength of the hub must be higher than that of the gear teeth. The maximum bore size should be 60% to 70% of the hub diameter (or tooth root diameter), and 50% to 60% for keyway applied modifications. Also, because the cast FC200 hub is weaker and more brittle than other steels, we recommend using a maximum bore diameter about 10% smaller.
- ③ As the worm wheel is casted, bubbles may form inside the material. If the air bubbles found in secondary operations are problematic, contact the supplier.

### 3. Points of Caution during Assembly

- ① The recommended center distance tolerance of KHK stock worm gears is H7 for ground gears and H8 for cut gears. The amount of backlash is given in the product table for each gear.
- ② The mounting reference surface of the worm wheel is as shown in the figure below.  
Assemble the worm wheel so that the center of the worm shaft is at the center of its tooth width.

Mounting Reference Surface

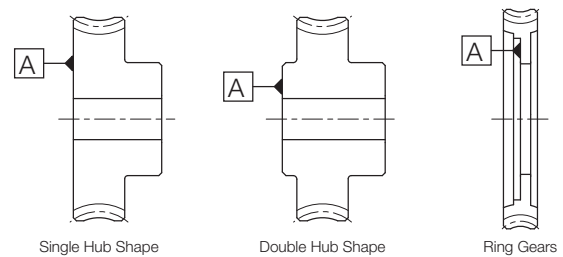

- ③ As the tooth trace of worm gears is spiraled, axial thrust force is generated. Also, the directions of thrust change with the hand of helix and the direction of rotation. This is illustrated below. The bearings must be selected properly to be able to handle these thrust forces. For details, use gear calculation software GCSW.

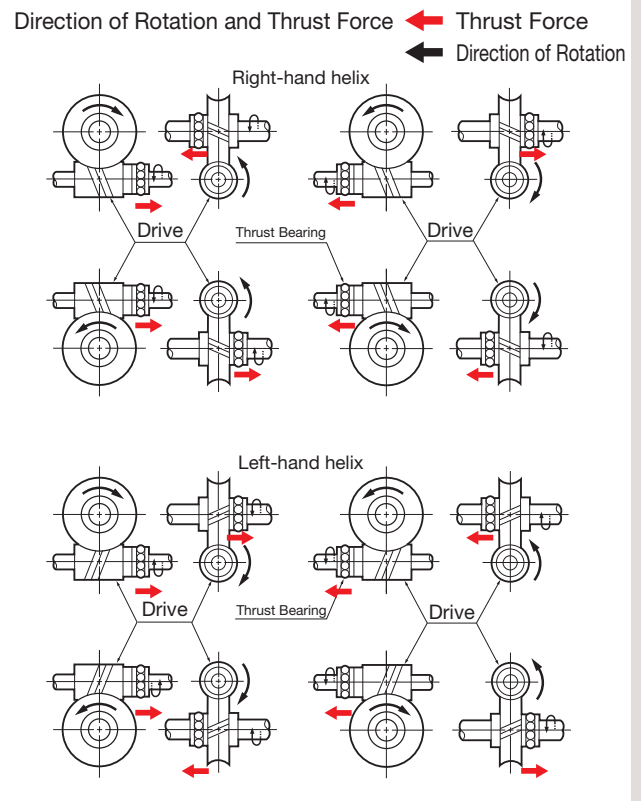

- ④ The worm may move due to a large thrust force that acts on the worm if it is not sufficiently attached to the shaft. Use a stepped shaft to secure the worm and shaft, and be careful not to loosen the bearing.

## 4. Confirming the installation

The wear of a worm gear is greatly affected by the quality of assembly. When assembling, confirm the following items for tooth contact and the like before use.

- The shaft angle tolerance between the worm shaft and worm wheel shaft is  $90^\circ \pm 1'$ .

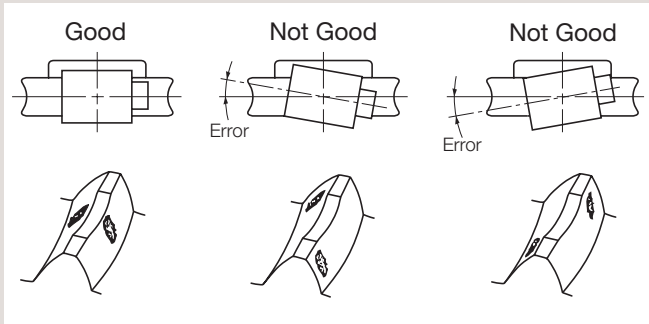

- The tolerance between the center of the worm shaft and center of the worm wheel tooth width is  $\pm 0.2$  mm.

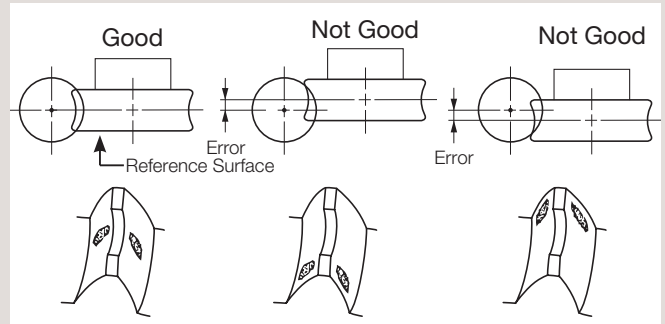

- The center distance tolerance recommended by the worm gear assembly distance is Ground Worm Gears...H7 Cut Worm Gears...H8.

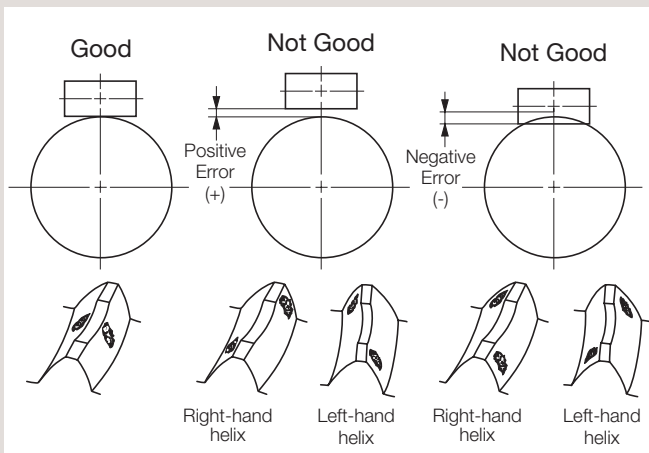

- The tolerance between the center of the worm wheel shaft and center of the worm tooth width is  $\pm 2$ mm.

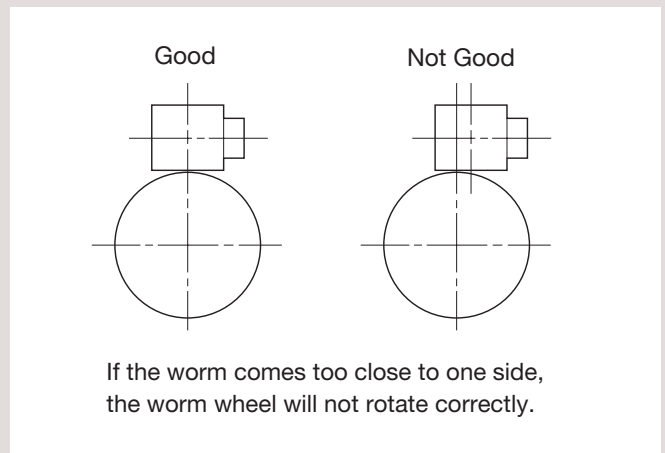

## 5. Cautions on Starting

- ① Check the following items before starting.
  - Are the gears installed securely?
  - Is there uneven tooth contact?
  - Is there adequate backlash? (Be sure to avoid zero-backlash.)
  - Has proper lubrication been supplied?
- ② If gears are exposed, be sure to attach a safety cover to ensure safety. Also, be careful not to touch rotating gears.
- ③ If there is any abnormality such as noise or vibration during startup, stop the operation immediately and check the assembly condition such as tooth contact, eccentricity and looseness.

KHK considers safety a priority in the use of our products.

When handling, adding secondary operations, assembling, and operating KHK products, please be aware of the following issues in order to prevent accidents.

### **Warning: Precautions for preventing physical and property damage**

1. When using KHK products, follow relevant safety regulations (Occupational Safety and Health Regulations, etc.).
2. Pay attention to the following items when installing, removing, or performing maintenance and inspection of the product.
  - ① Turn off the power switch.
  - ② Do not reach or crawl under the product.
  - ③ Wear appropriate clothing and protective equipment for the work.

### **Caution: Cautions in Preventing Accidents**

1. Before using a KHK product, read the precautions in the catalog carefully in order to use it correctly.
2. Avoid use in environments that may adversely affect the product.
3. Our products are manufactured under a superior quality control system based on the ISO9001 quality management system; if you notice any malfunctions upon purchasing a product, please contact the supplier.



## Description of duplex worm gears

The usual method of adjusting the backlash of a worm gear assembly is to modify the center distance. Once assembled, such adjustment requires a major rework of the gearbox housing. The use of duplex worm gears allows the backlash adjustment to be made by axially shifting the worm. This simplifies greatly the assembly and maintenance operations. Because of the unique characteristics of the product, please take time to study its construction and proper use.

## Backlash adjustment mechanism and method of adjustment

The dual-lead worm is formed to give a difference between the right tooth surface and left tooth surface so that it provides a unique tooth profile in which the tooth thickness varies continuously, corresponding with the lead difference. (Fig.1)

The worm gear is also formed in its right and left tooth surface. When such a worm and worm gear are set up at a constant assembly distance and the worm is moved in the axial direction, the tooth thickness of the worm in mesh with the worm gear changes making backlash adjustment possible.

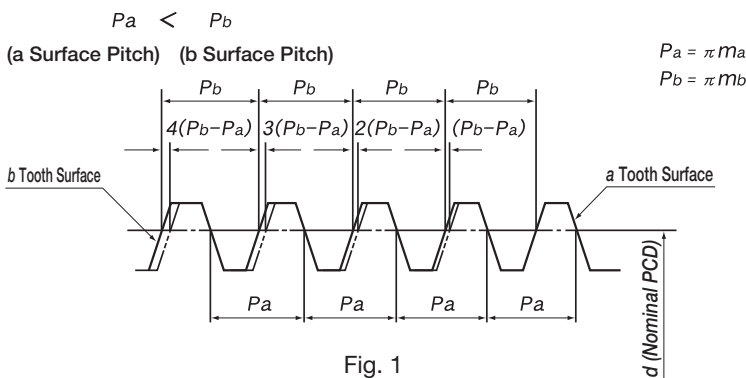

[CAUTION] The amount of change in backlash ( $\Delta j$  mm) in relation to the axial movement of the duplex worm shaft ( $V$  mm) can be calculated from the formula below.

$$\Delta j = 2V \frac{m_b - m_a}{m_a + m_b}$$

Where

$m_a$  = Nominal Axial Module - (0.01 × Nominal Axial Module)

$m_b$  = Nominal Axial Module + (0.01 × Nominal Axial Module)



An arrow marking on the outer circumference of the hub of the KHK duplex worm indicates the direction of assembly as well as acts as a direction for the backlash adjustment. When the worm is held with arrow mark pointing right, the tooth thickness is thinner on the right and thicker on the left. Therefore, moving the worm to the right causes the thicker teeth to come into actual engagement with the worm gear, thereby reducing the backlash. (Fig.2)

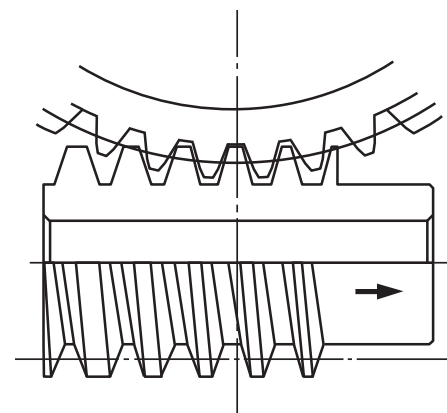

Moving the worm in the direction of the arrow diminishes the backlash.

Fig. 2

[CAUTION] The KHK duplex worm is designed so that, for all modules, the backlash reduces by 0.02 mm when the worm is shifted 1 mm.

## Application Examples

\* The illustration is a design example, not a design for machinery or a device in actual use.

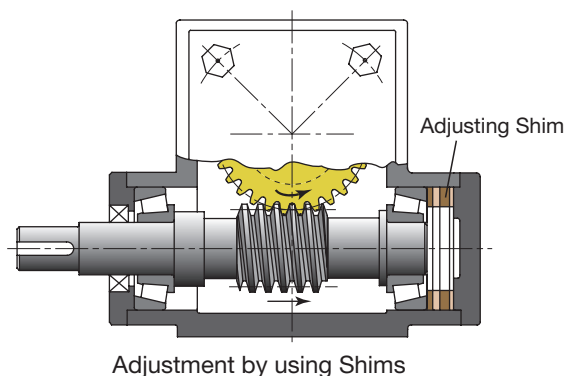
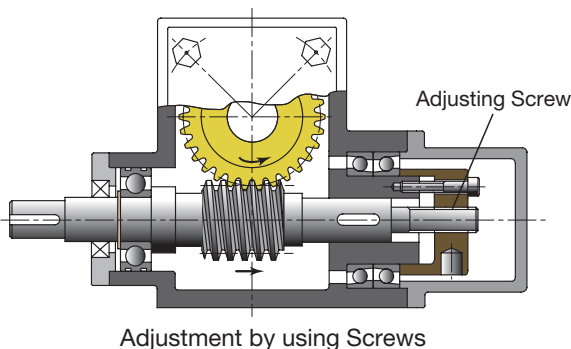

## Points of caution during assembly

KHK duplex worm gears differ in module between the right and left tooth surface and, therefore, you must orient the worm and worm wheel properly. Please carefully verify the following two aspects before proceeding with assembly.

### 1. Verifying the orientation of assembly

An arrow indicating the orientation of assembly is stamped on both the duplex worm and worm wheel. When assembling the worm and worm wheel, check the worm wheel of the arrow mark on the front such that the direction of arrow mark on the worm coincides with that on the worm wheel. Incorrect assembly results in difficulty of assembly and improper gear engagement. (Fig.3)

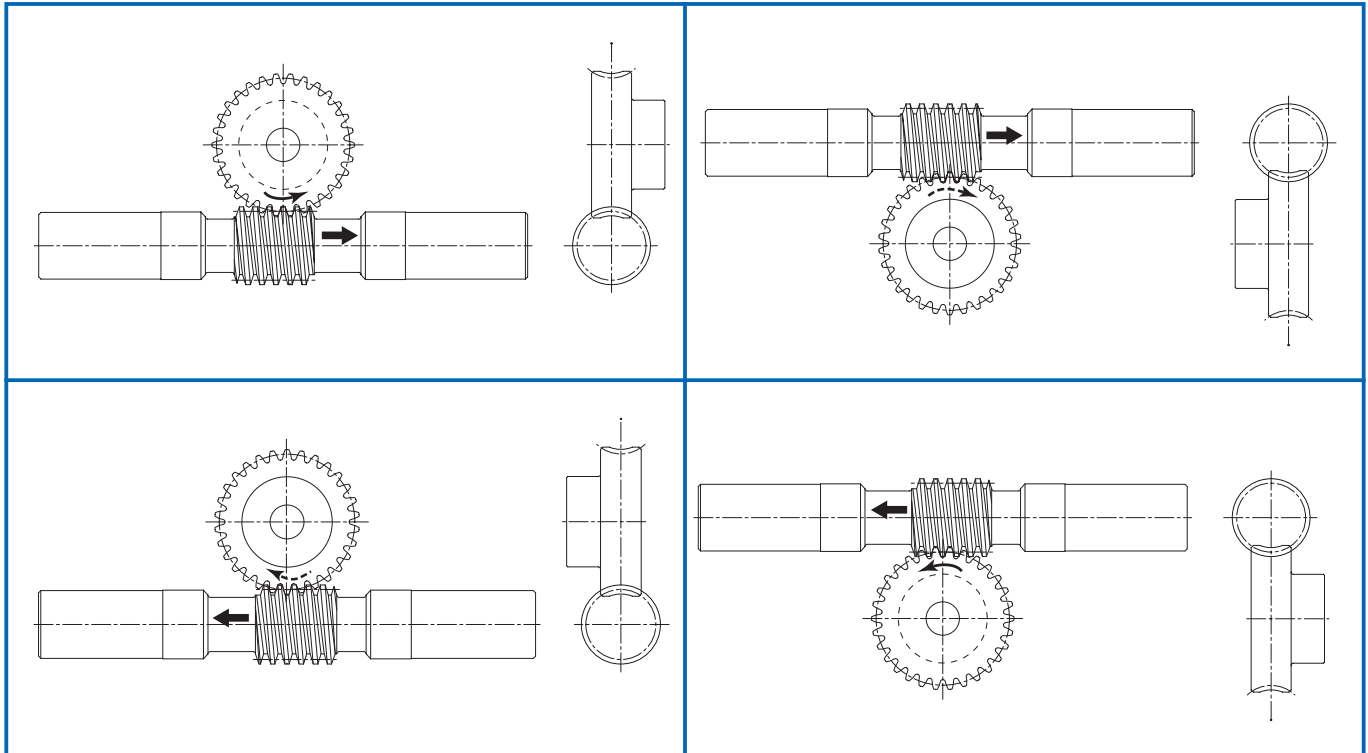

Arrow mark indicates the correct orientation of two gears when assembled. As shown, the two arrows must point in the same direction.

Fig. 3

### 2. Verifying the reference position

A V-groove (60°, 0.3 mm deep line) on tip peripheral of the duplex worm tooth marks the reference tooth. The gear set is designated to have a backlash of nearly zero (tolerance:  $\pm 0.045$ ) when the reference tooth is positioned in alignment with the center of rotation of the worm wheel with the center distance set at the value "a". (Fig.4)

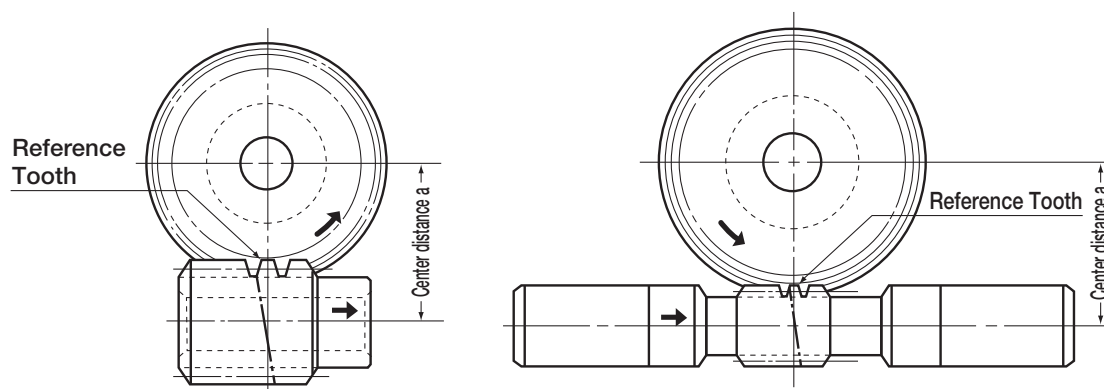

Fig. 4



Spur  
Gears

Helical  
Gears

Internal  
Gears

Racks

CP Racks &  
Pinions

Miter  
Gears

Bevel  
Gears

Screw  
Gears

Worm  
Gears

Gearboxes

Other  
Products



Specifications	
Precision grade	KHK W 001 grade 1
Reference section of gear	Axial direction
Gear teeth	Standard full depth
Normal pressure angle	17°30'
Material	SCM440
Heat treatment	Thermal refined, gear teeth induction hardened*
Tooth hardness	50 to 60HRC
Surface treatment	Black oxide coated except for ground part

\* Due to the gear teeth being induction hardened, no secondary operations can be performed on tooth areas including the bottom land (approx. 2 to 3 mm).

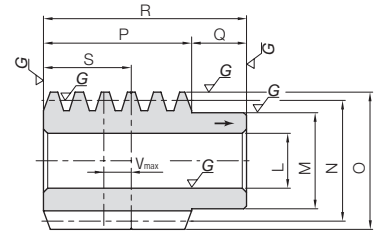

W4

Catalog Number	Nominal axial module	Number of Starts	Nominal lead angle	Direction of helix	Shape	Bore	Hub dia.	Pitch dia.	Outside dia.	Face width	Hub width	Total length
						L <sub>H7</sub>	M	N	O	P	Q	R
<b>KWGD2-R1</b>	<b>m2</b>	1	3°41'	R	W4	14	25	31	35	36	14	50

Catalog Number	Nominal axial module	Number of Starts	Nominal lead angle	Direction of helix	Shape	Total Length	Shaft length (L)	Neck length (left)	Face width	Neck length (right)	Shaft length (R)	Pitch dia.
						J	K	L	M	N	O	P
<b>KWGDLS1.5-R1</b>	<b>m1.5</b>	1	3°26'	R	W6	190	66	12	28	18	66	25
<b>KWGDLS2-R1</b>	<b>m2</b>	1	3°41'	R	W6	220	75	13	36	21	75	31

[Caution on Product Characteristics] ① When adjusting the worm to reduce the backlash, V<sub>max</sub> is the maximum amount of distance that you may shift it without causing problems with the gear mesh. V<sub>max</sub> is not the recommended value to use for adjustment during assembly.



CP Racks &  
Pinions

Miter  
Gears

Bevel  
Gears

Screw  
Gears

Worm  
Gears

Gearboxes

Other  
Products



Specifications	
Precision grade	KHK W 002 grade 1
Reference section of gear	Rotating plane
Gear teeth	Standard full depth
Normal pressure angle	17°30'
Material	CAC702 (old JIS A & BC2)
Heat Treatment	—
Tooth hardness	—

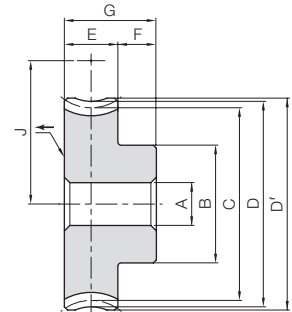

H1

Catalog Number	Reduction ratio	Nominal transverse module	No. of teeth	Lead angle	Direction of helix	Shape	Bore	Hub dia.	Pitch dia.	Throat dia.	Outside dia.	Face width	Hub width
							A <sub>H7</sub>	B	C	D	D'	E	F
<b>AGDL1.5-20R1</b>	20	<b>m1.5</b>	20	3°26'	R	H1	8	22	30	33	34.5	14	10
<b>AGDL1.5-30R1</b>	30		10				30	45	48	49.5			
<b>AGDL1.5-40R1</b>	40		12				35	60	63	64.5			
<b>AGDL1.5-50R1</b>	50		12				45	75	78	79.5			
<b>AGDL1.5-60R1</b>	60		12				50	90	93	94.5			
<b>AGDL2-20R1</b>	20	<b>m2</b>	20	3°41'	R	H1	12	33	40	44	46	18	15
<b>AGDL2-30R1</b>	30		15				40	60	64	66			
<b>AGDL2-40R1</b>	40		15				45	80	84	86			
<b>AGDL2-50R1</b>	50		15				50	100	104	106			
<b>AGDL2-60R1</b>	60		15				60	120	124	126			

[Caution on Product Characteristics] ① For duplex worm gears, mount the worm and wheel with the arrows pointing in the same direction. The arrows on the wheels indicate the direction of assembly and do not determine the direction of rotation. See assembly instructions on page 404.



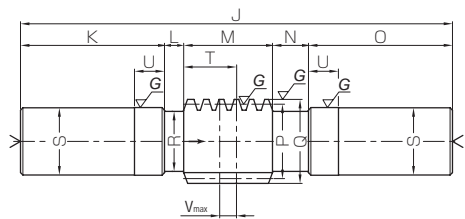

W6

Position of reference tooth	Max. allowable shift	Weight (kg)	Catalog Number
S	Vmax		
22	8	0.21	<b>KWGDLS2-R1</b>

Outside dia.	Neck dia.	Shaft dia.	Position of reference tooth	Grinding length of shaft	Max. allowable shift	Weight (kg)	Catalog Number
Q	R	S	T	U	Vmax		
28	21	26.2	17	20	6	0.74	<b>KWGDLS1.5-R1</b>
35	24	30.2	22	20	8	1.17	<b>KWGDLS2-R1</b>

Duplex Worm Wheels



Total length	Web thickness	Web O.D.	Mounting distance	Allowable torque (N·m) <small>NOTE 1</small>							Backlash (mm)	Weight (kg)	Catalog Number	
				30 <sub>rpm</sub>	100 <sub>rpm</sub>	300 <sub>rpm</sub>	600 <sub>rpm</sub>	900 <sub>rpm</sub>	1200 <sub>rpm</sub>	1800 <sub>rpm</sub>				
24	—	—	27.5	9.84	8.18	6.40	5.30	4.68	4.25	3.68	0±0.045	0.10	<b>AGDL1.5-20R1</b>	
			35	20.8	17.5	13.9	11.7	10.4	9.40	8.28			0.22	<b>AGDL1.5-30R1</b>
			42.5	35.6	30.0	24.2	20.6	18.3	16.6	14.6			0.37	<b>AGDL1.5-40R1</b>
			50	53.8	45.4	36.9	31.6	28.3	25.8	22.6			0.59	<b>AGDL1.5-50R1</b>
			57.5	75.3	63.8	51.9	44.7	40.4	36.7	32.4			0.83	<b>AGDL1.5-60R1</b>
33	—	—	35.5	21.0	17.5	13.6	11.2	9.84	8.94	7.75	0±0.045	0.26	<b>AGDL2-20R1</b>	
			45.5	44.3	37.3	29.6	24.8	21.9	19.8	17.4			0.51	<b>AGDL2-30R1</b>
			55.5	75.8	64.0	51.4	43.6	38.5	34.9	30.7			0.86	<b>AGDL2-40R1</b>
			65.5	115	96.8	78.4	66.9	59.5	54.2	47.6			1.30	<b>AGDL2-50R1</b>
			75.5	160	136	110	94.6	84.9	77.2	68.1			1.88	<b>AGDL2-60R1</b>

[NOTE 1] Allowable torque based on worm speed (rpm).



Spur Gears

Helical Gears

Internal Gears

Racks

CP Racks & Pinions

Miter Gears

Bevel Gears

Screw Gears

Worm Gears

Gearboxes

Other Products



Specifications	
Precision grade	KHK W 001 grade 1
Reference section of gear	Axial direction
Gear teeth	Standard full depth
Normal pressure angle	17°30'
Material	SCM440
Heat treatment	Thermal refined, gear teeth induction hardened*
Tooth hardness	50 to 60HRC
Surface treatment	Black oxide coated except for ground part

\* Due to the gear teeth being induction hardened, no secondary operations can be performed on tooth areas including the bottom land (approx. 2 to 3 mm).

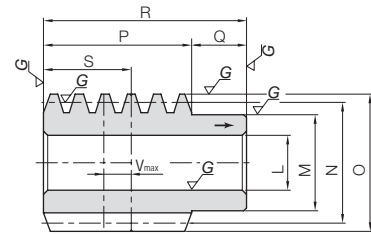

**W4**

Catalog Number	Nominal axial module	Number of Starts	Nominal lead angle	Direction of helix	Shape	Bore	Hub dia.	Pitch dia.	Outside dia.	Face width	Hub width	Total length
						L <sub>H7</sub>	M	N	O	P	Q	R
<b>KWGD2.5-R1</b>	<b>m2.5</b>	1	3°52'	R	W4	18	30	37	42	48	17	65
<b>KWGD3-R1</b>	<b>m3</b>	1	3°54'	R	W4	20	35	44	50	54	20	74

Catalog Number	Nominal axial module	Number of Starts	Nominal lead angle	Direction of helix	Shape	Total Length	Shaft length (L)	Neck length (left)	Face width	Neck length (right)	Shaft length (R)	Pitch dia.
						J	K	L	M	N	O	P
<b>KWGDLS2.5-R1</b>	<b>m2.5</b>	1	3°52'	R	W6	260	85	16	48	26	85	37
<b>KWGDLS3-R1</b>	<b>m3</b>	1	3°54'	R	W6	300	100	18	54	28	100	44

[Caution on Product Characteristics] ① When adjusting the worm to reduce the backlash, V<sub>max</sub> is the maximum amount of distance that you may shift it without causing problems with the gear mesh. V<sub>max</sub> is not the recommended value to use for adjustment during assembly.



Spur Gears

Helical Gears

Internal Gears

Racks

CP Racks & Pinions

Miter Gears

Bevel Gears

Screw Gears

Worm Gears

Gearboxes

Other Products



Specifications	
Precision grade	KHK W 002 grade 1
Reference section of gear	Rotating plane
Gear teeth	Standard full depth
Normal pressure angle	17°30'
Material	CAC702 (old JIS A & BC2)
Heat Treatment	—
Tooth hardness	—

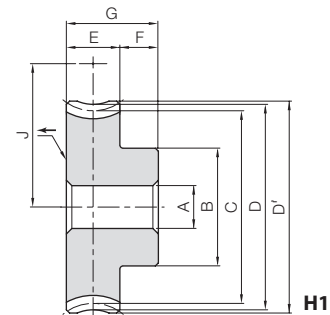

**H1**

Catalog Number	Reduction ratio	Nominal transverse module	No. of teeth	Lead angle	Direction of helix	Shape	Bore	Hub dia.	Pitch dia.	Throat dia.	Outside dia.	Face width	Hub width
							A <sub>H7</sub>	B	C	D	D'	E	F
<b>AGDL2.5-36R1</b>	36	<b>m2.5</b>	36	3°52'	R	H1	15	45	90	95	97.5	22	15
<b>AGDL2.5-40R1</b>	40		45			100		105	107.5				
<b>AGDL2.5-50R1</b>	50		60			125		130	132.5				
<b>AGDL2.5-60R1</b>	60		80			150		155	157.5				
<b>AGDL3-30R1</b>	30	<b>m3</b>	30	3°54'	R	H1	20	55	90	96	99	28	17
<b>AGDL3-36R1</b>	36		60			108		114	117				
<b>AGDL3-40R1</b>	40		60			120		126	129				
<b>AGDL3-50R1</b>	50		70			150		156	159				
<b>AGDL3-60R1</b>	60		80			180		186	189				

[Caution on Product Characteristics] ① For duplex worm gears, mount the worm and wheel with the arrows pointing in the same direction. The arrows on the wheels indicate the direction of assembly and do not determine the direction of rotation. See assembly instructions on page 404.



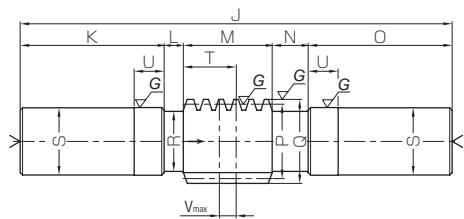

W6

Position of reference tooth	Max. allowable shift	Weight (kg)	Catalog Number
S	Vmax		
29	10	0.37	<b>KWGDLS2.5-R1</b>
32	10	0.61	<b>KWGDLS3-R1</b>

Outside dia.	Neck dia.	Shaft dia.	Position of reference tooth	Grinding length of shaft	Max. allowable shift	Weight (kg)	Catalog Number
Q	R	S	T	U	Vmax		
42	30	36.2	29	25	10	2.00	<b>KWGDLS2.5-R1</b>
50	34	40.2	32	25	10	2.95	<b>KWGDLS3-R1</b>

Duplex Worm Wheels

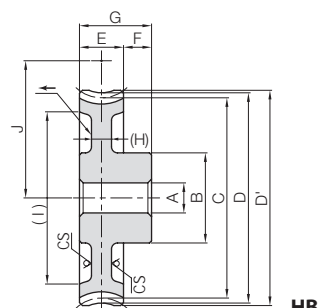

HB

\* CS has a forged finish surface.



Total length	Web thickness	Web O.D.	Mounting distance	Allowable torque (N·m) <small>NOTE 1</small>								Backlash (mm)	Weight (kg)	Catalog Number
				30 rpm	100 rpm	300 rpm	600 rpm	900 rpm	1200 rpm	1800 rpm				
37	—	—	63.5	113	94.5	75.5	63.8	56.0	51.0	44.3	0±0.045	1.25	<b>AGDL2.5-36R1</b>	
	(10)	(86)	68.5	138	115	92.4	78.3	68.8	62.7	54.4			1.14	<b>AGDL2.5-40R1</b>
	(12)	(108)	81	208	174	141	120	106	97.3	84.3			1.93	<b>AGDL2.5-50R1</b>
	(12)	(133)	93.5	291	245	198	170	152	139	121			2.90	<b>AGDL2.5-60R1</b>
45	—	—	67	137	114	90.0	74.7	65.5	59.5	51.2	0±0.045	1.65	<b>AGDL3-30R1</b>	
	—	—	76	193	160	128	107	93.8	85.6	73.4			2.32	<b>AGDL3-36R1</b>
	(14)	(106)	82	235	195	157	131	115	105	90.1			2.19	<b>AGDL3-40R1</b>
	(14)	(134)	97	355	295	239	202	178	163	140			3.26	<b>AGDL3-50R1</b>
	(14)	(164)	112	497	415	336	285	254	233	200			4.48	<b>AGDL3-60R1</b>

[NOTE 1] Allowable torque based on worm speed (rpm).

- Spur Gears
- Helical Gears
- Internal Gears
- Racks
- CP Racks & Pinions
- Miter Gears
- Bevel Gears
- Screw Gears
- Worm Gears
- Gearboxes
- Other Products



Spur Gears

Helical Gears

Internal Gears

Racks

CP Racks & Pinions

Miter Gears

Bevel Gears

Screw Gears

Worm Gears

Gearboxes

Other Products



Specifications	
Precision grade	KHK W 001 grade 1
Reference section of gear	Axial direction
Gear teeth	Standard full depth
Normal pressure angle	17°30'
Material	SCM440
Heat treatment	Thermal refined, gear teeth induction hardened*
Tooth hardness	50 to 60HRC
Surface treatment	Black oxide coated except for ground part

\* Due to the gear teeth being induction hardened, no secondary operations can be performed on tooth areas including the bottom land (approx. 2 to 3 mm).

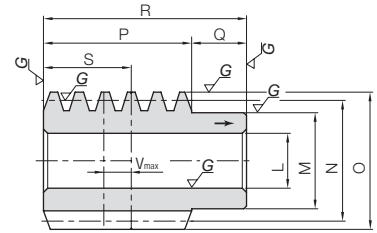

W4

Catalog Number	Nominal axial module	Number of Starts	Nominal lead angle	Direction of helix	Shape	Bore	Hub dia.	Pitch dia.	Outside dia.	Face width	Hub width	Total length
						L <sub>H7</sub>	M	N	O	P	Q	R
<b>KWGL3.5-R1</b>	<b>m3.5</b>	1	3°47'	R	W4	24	44	53	60	62	23	85
<b>KWGL4-R1</b>	<b>m4</b>	1	3°41'	R	W4	28	50	62	70	74	26	100

Catalog Number	Nominal axial module	Number of Starts	Nominal lead angle	Direction of helix	Shape	Total Length	Shaft length (L)	Neck length (left)	Face width	Neck length (right)	Shaft length (R)	Pitch dia.
						J	K	L	M	N	O	P
<b>KWGLS3.5-R1</b>	<b>m3.5</b>	1	3°47'	R	W6	330	110	18	62	30	110	53
<b>KWGLS4-R1</b>	<b>m4</b>	1	3°41'	R	W6	360	120	16	74	30	120	62

[Caution on Product Characteristics] ① When adjusting the worm to reduce the backlash, V<sub>max</sub> is the maximum amount of distance that you may shift it without causing problems with the gear mesh. V<sub>max</sub> is not the recommended value to use for adjustment during assembly.



Spur Gears

Helical Gears

Internal Gears

Racks

CP Racks & Pinions

Miter Gears

Bevel Gears

Screw Gears

Worm Gears

Gearboxes

Other Products



Specifications	
Precision grade	KHK W 002 grade 1
Reference section of gear	Rotating plane
Gear teeth	Standard full depth
Normal pressure angle	17°30'
Material	CAC702 (old JIS A & BC2) *
Heat treatment	—
Tooth hardness	—

\*The hub material of H5 is S45C.

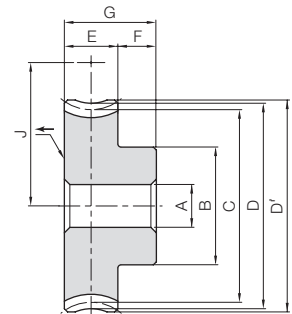

H1

Catalog Number	Reduction ratio	Nominal transverse module	No. of teeth	Lead angle	Direction of helix	Shape	Bore	Hub dia.	Pitch dia.	Throat dia.	Outside dia.	Face width	Hub width
							A <sub>H7</sub>	B	C	D	D'	E	F
<b>AGDL3.5-30R1</b>	30	<b>m3.5</b>	30	3°47'	R	H1	20	60	105	112	115.5	32	18
<b>AGDL3.5-40R1 (Made to Order)</b>	40	<b>m3.5</b>	40	3°47'	R	HB	20	70	140	147	150.5	32	18
<b>AGDL3.5-50R1</b>	50	<b>m3.5</b>	50	3°47'	R	HB	20	80	175	182	185.5	32	18
<b>AGDL3.5-60R1</b>	60	<b>m3.5</b>	60	3°47'	R	HB	20	90	210	217	220.5	32	18
<b>AGDL4-30R1 (Made to Order)</b>	30	<b>m4</b>	30	3°41'	R	HB	20	65	120	128	132	35	20
<b>AGDL4-36R1 (Made to Order)</b>	36	<b>m4</b>	36	3°41'	R	HB	20	75	144	152	156	35	20
<b>AGDL4-40R1</b>	40	<b>m4</b>	40	3°41'	R	HB	20	75	160	168	172	35	20
<b>AGDL4-50R1</b>	50	<b>m4</b>	50	3°41'	R	HB	20	90	200	208	212	35	20
<b>AGDL4-60R1</b>	60	<b>m4</b>	60	3°41'	R	H5	30	120	240	248	252	35	20

[Caution on Product Characteristics] ① For duplex worm gears, mount the worm and wheel with the arrows pointing in the same direction. The arrows on the wheels indicate the direction of assembly and do not determine the direction of rotation. See assembly instructions on page 404.

[Precautions for Made to Order Products] ① Prices and lead times for Made to Order products require separate estimates. Contact your dealer.



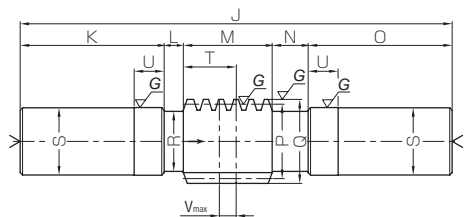

W6

Position of reference tooth	Max. allowable shift	Weight (kg)	Catalog Number
S	Vmax		
37	12	1.05	<b>KWGDLS3.5-R1</b>
44	14	1.67	<b>KWGDLS4-R1</b>

Outside dia.	Neck dia.	Shaft dia.	Position of reference tooth	Grinding length of shaft	Max. allowable shift	Weight (kg)	Catalog Number
Q	R	S	T	U	Vmax		
60	42	48.2	37	25	12	4.72	<b>KWGDLS3.5-R1</b>
70	50	56.2	44	25	14	7.10	<b>KWGDLS4-R1</b>

Duplex Worm Wheels

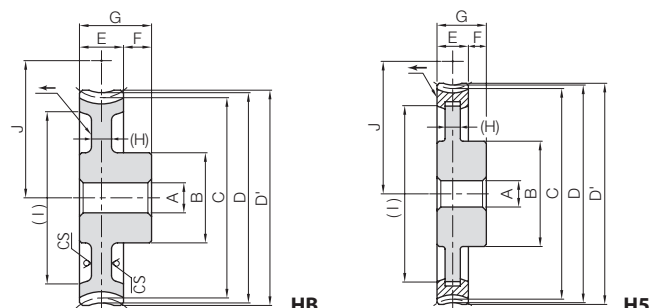

\* CS has a forged finish surface.



Total length	Web thickness	Web O.D.	Mounting distance	Allowable torque (N·m) <small>NOTE 1</small>							Backlash (mm)	Weight (kg)	Catalog Number
				30 <sub>rpm</sub>	100 <sub>rpm</sub>	300 <sub>rpm</sub>	600 <sub>rpm</sub>	900 <sub>rpm</sub>	1200 <sub>rpm</sub>	1800 <sub>rpm</sub>			
50	—	—	79	208	172	136	111	98.1	88.3	75.7	0±0.045	2.51	<b>AGDL3.5-30R1</b>
50	(15)	(124)	96.5	356	295	236	196	173	156	133	0±0.045	3.34	<b>AGDL3.5-40R1 (Made to Order)</b>
50	(16)	(155)	114	538	446	360	301	267	243	207	0±0.045	5.02	<b>AGDL3.5-50R1</b>
	(16)	(189)	131.5	753	627	506	425	381	345	296		6.87	<b>AGDL3.5-60R1</b>
55	(17)	(99)	91	284	234	184	150	132	118	101	0±0.045	3.01	<b>AGDL4-30R1 (Made to Order)</b>
	(17)	(121)	103	400	329	262	215	190	170	144		4.18	<b>AGDL4-36R1 (Made to Order)</b>
55	(17)	(137)	111	486	400	320	264	233	208	177	0±0.045	4.78	<b>AGDL4-40R1</b>
	(17)	(177)	131	735	605	488	405	361	324	275		7.07	<b>AGDL4-50R1</b>
	(17)	(200)	151	1030	851	687	572	515	461	393		11.5	<b>AGDL4-60R1</b>

[NOTE 1] Allowable torque based on worm speed (rpm).



Specifications	
Precision grade	KHK W 001 grade 1
Reference section of gear	Axial direction
Gear teeth	Standard full depth
Normal pressure angle	17°30'
Material	SCM440
Heat treatment	Thermal refined, gear teeth induction hardened*
Tooth hardness	50 to 60HRC
Surface treatment	—

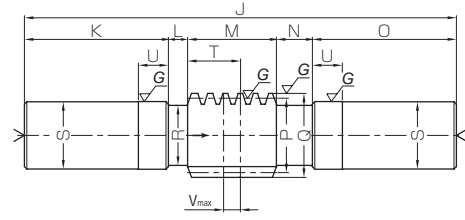

W6

\* Due to the gear teeth being induction hardened, no secondary operations can be performed on tooth areas including the bottom land (approx. 2 to 3 mm).

Catalog Number	Nominal axial module	Number of Starts	Nominal lead angle	Direction of helix	Shape	Total Length	Shaft length (L)	Neck length (left)	Face width	Neck length (right)	Shaft length (R)	Pitch dia.
						J	K	L	M	N	O	P
<b>KWGDLS5-R1S</b>	<b>m5</b>	1	4°05'	R	W6	400	130	17	90	33	130	70
<b>KWGDLS6-R1S</b>	<b>m6</b>	1	4°17'	R	W6	400	120	18	105	37	120	80

- [Caution on Product Characteristics] ① When adjusting the worm to reduce the backlash, Vmax is the maximum amount of distance that you may shift it without causing problems with the gear mesh. Vmax is not the recommended value to use for adjustment during assembly.
- ② Products with S at the end of the catalog number are semi-custom stock products. See page 42 for lead times and allowable order quantities. See page 44 for other precautions.

Spur Gears  
Helical Gears  
Internal Gears  
Racks  
CP Racks & Pinions  
Miter Gears  
Bevel Gears  
Screw Gears  
Worm Gears  
Gearboxes  
Other Products



Specifications	
Precision grade	KHK W 002 grade 1
Reference section of gear	Rotating plane
Gear teeth	Standard full depth
Normal pressure angle	17°30'
Material	CAC702 (old JIS A & BC2)
Heat treatment	—
Tooth hardness	—

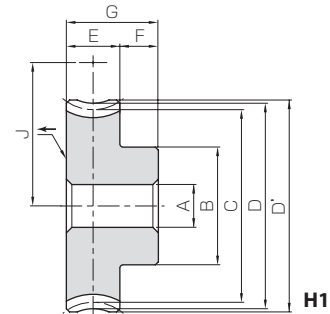

Catalog Number	Reduction ratio	Nominal transverse module	No. of teeth	Lead angle	Direction of helix	Shape	Bore	Hub dia.	Pitch dia.	Throat dia.	Outside dia.	Face width	Hub width
							AH7	B	C	D	D'	E	F
<b>AGDL5-20R1S</b>	20	<b>m5</b>	20	4°05'	R	H1	25	70	100	110	115	42	23
<b>AGDL5-30R1S</b>	30		25				80	150	160	165	23		
<b>AGDL5-40R1S</b>	40		25				90	200	210	215	5		
<b>AGDL5-50R1S</b>	50		150				230	250	260	265	5		
<b>AGDL5-60R1S</b>	60		200				280	300	310	315	5		
<b>AGDL6-20R1S</b>	20	<b>m6</b>	20	4°17'	R	H1	30	85	120	132	138	46	24
<b>AGDL6-30R1S</b>	30		30				90	180	192	198	24		
<b>AGDL6-40R1S</b>	40		130				220	240	252	258	5		
<b>AGDL6-50R1S</b>	50		190				280	300	312	318	5		
<b>AGDL6-60R1S</b>	60		250				340	360	372	378	5		

- [Caution on Product Characteristics] ① For duplex worm gears, mount the worm and wheel with the arrows pointing in the same direction. The arrows on the wheels indicate the direction of assembly and do not determine the direction of rotation. See assembly instructions on page 404.
- ② Products with S at the end of the catalog number are semi-custom stock products. See page 42 for lead times and allowable order quantities. See page 44 for other precautions.
- ③ For S semi-custom standard products weighing 15 kg or more, eyebolt screw threads (2-M12 depth 25 mm) are machined around the outside of the hub side surface. Details of the PCD of the screw threads are located on page 51.



Outside dia.	Neck dia.	Shaft dia.	Position of reference tooth	Grinding length of shaft	Max. allowable shift	Weight (kg)	Catalog Number	
Q	R	S	T	U	Vmax			
80	54	60	53	30	16	9.39	<a href="#">KWGDL55-R1S</a>	Ⓢ
92	60	70	62	30	20	12.6	<a href="#">KWGDL56-R1S</a>	Ⓢ

Duplex Worm Wheels



Total length	Mounting distance	Allowable torque (N·m) <small>NOTE 1</small>								Backlash (mm)	Weight (kg)	Catalog Number	
		30 <sub>rpm</sub>	100 <sub>rpm</sub>	300 <sub>rpm</sub>	600 <sub>rpm</sub>	900 <sub>rpm</sub>	1200 <sub>rpm</sub>	1800 <sub>rpm</sub>					
65	85	243	195	152	122	106	94.8	78.6	0±0.045	3.17	<a href="#">AGDL5-20R1S</a>	Ⓢ	
65	110	513	418	330	269	236	210	177		6.62	<a href="#">AGDL5-30R1S</a>	Ⓢ	
65	135	878	716	573	473	415	370	311		11.4	<a href="#">AGDL5-40R1S</a>	Ⓢ	
47	160	1330	1080	875	726	641	575	482		11.5	<a href="#">AGDL5-50R1S</a>	Ⓢ	
47	185	1860	1520	1230	1030	915	819	690		14.3	<a href="#">AGDL5-60R1S</a>	Ⓢ	
70	100	362	290	225	180	155	139	115	0±0.045	4.93	<a href="#">AGDL6-20R1S</a>	Ⓢ	
70	130	766	619	488	398	345	307	258		10.2	<a href="#">AGDL6-30R1S</a>	Ⓢ	
51	160	1310	1060	848	700	607	543	453		12.7	<a href="#">AGDL6-40R1S</a>	Ⓢ	
51	190	1980	1610	1290	1070	938	843	703		16.8	<a href="#">AGDL6-50R1S</a>	Ⓢ	
51	220	2770	2260	1820	1520	1340	1200	1010		20.9	<a href="#">AGDL6-60R1S</a>	Ⓢ	

[NOTE 1] Allowable torque based on worm speed (rpm).



# Ground Worm Shafts

Spur Gears

Helical Gears

Internal Gears

Racks

CP Racks & Pinions

Miter Gears

Bevel Gears

Screw Gears

Worm Gears

Gearboxes

Other Products



Specifications	
Precision grade	KHK W 001 grade 2
Reference section of gear	Axial direction
Gear teeth	Standard full depth
Normal pressure angle	20°
Material	SCM440
Heat treatment	Thermal refined, gear teeth induction hardened*
Tooth hardness	50 to 60HRC

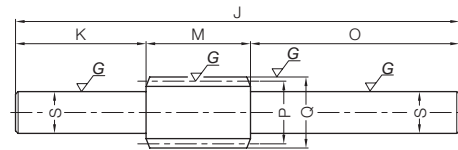

W5

\* Due to the gear teeth being induction hardened, no secondary operations can be performed on tooth areas including the bottom land (approx. 2 to 3 mm).

Catalog Number	Axial module	Number of Starts	Nominal lead angle	Direction of helix	Shape	Total Length	Shaft length (L)	Neck length (left)	Face width	Neck length (right)	Shaft length (R)	Pitch dia.
						J	K	L	M	N	O	P
KWG0.5-R1 KWG0.5-R2	<b>m0.5</b>	1 2	3°11' 6°20'	R	W5	65	19	—	12	—	34	9
KWG0.8-R1 KWG0.8-R2	<b>m0.8</b>	1 2	3°49' 7°36'	R	W5	85	25	—	20	—	40	12



# Worm Wheels

Miter Gears

Bevel Gears

Screw Gears

Worm Gears

Gearboxes

Other Products



Specifications	
Precision grade	KHK W 002 grade 2
Reference section of gear	Rotating plane
Gear teeth	Standard full depth
Normal pressure angle	20°
Material	CAC702 (old JIS A & BC2)
Heat Treatment	—
Tooth hardness	—

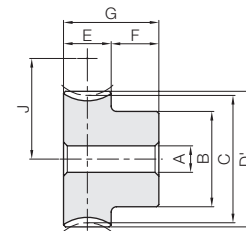

HA

Catalog Number	Reduction ratio	Transverse module	No. of teeth	No. of starts of mating worm	Lead angle	Direction of helix	Shape	Bore	Hub dia.	Pitch dia.	Throat dia.	Outside dia.	Face width	Hub width
								AH7	B	C	D	D'	E	F
AG0.5-20R1	20	<b>m0.5</b>	20	1	3°11'	R	HA	4	9	10	—	11	5	7
AG0.5-20R2	10		4	9	10			11						
AG0.5-30R1	30		4	12	15			16						
AG0.5-40R1	40		5	15	20			21						
AG0.5-50R1	50		5	20	25			26						
AG0.5-60R1	60		5	25	30			31						
AG0.8-20R1	20	<b>m0.8</b>	20	1	3°49'	R	HA	5	12	16	—	17.6	8	8
AG0.8-20R2	10		5	12	16			17.6						
AG0.8-30R1	30		5	18	24			25.6						
AG0.8-30R2	15		5	18	24			25.6						
AG0.8-40R1	40		6	20	32			33.6						
AG0.8-50R1	50		8	25	40			41.6						
AG0.8-60R1	60		8	25	48			49.6						



Outside dia.	Neck dia.	Shaft dia.	Grinding length of shaft	Weight (kg)	Catalog Number
Q	R	S <sub>H7</sub>	U		
10	—	6	—	0.018	<b>KWG0.5-R1</b> <b>KWG0.5-R2</b>
13.6	—	8	—	0.043	<b>KWG0.8-R1</b> <b>KWG0.8-R2</b>

Worm Wheels

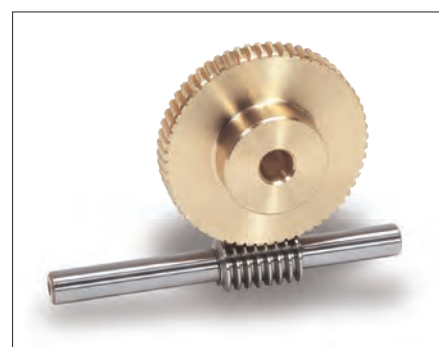

Total length	Web thickness	Web O.D.	Mounting distance	Allowable torque (N·m) <small>NOTE 1</small>							Backlash (mm)	Weight (kg)	Catalog Number				
				30 rpm	100 rpm	300 rpm	600 rpm	900 rpm	1200 rpm	1800 rpm							
G	(H)	(I)	J														
12	—	—	9.5	0.52	0.44	0.36	0.30	0.26	0.24	0.21	0.02~0.12	0.0056	<b>AG0.5-20R1</b> <b>AG0.5-20R2</b> <b>AG0.5-30R1</b> <b>AG0.5-40R1</b> <b>AG0.5-50R1</b> <b>AG0.5-60R1</b>				
			9.5	0.51	0.42	0.33	0.27	0.24	0.22	0.19		0.0056					
			12	1.09	0.94	0.77	0.65	0.58	0.53	0.48		0.012					
			14.5	1.86	1.60	1.34	1.15	1.02	0.94	0.84		0.020					
			17	2.82	2.42	2.05	1.77	1.58	1.46	1.30		0.035					
			19.5	3.94	3.41	2.89	2.50	2.26	2.08	1.87	0.053						
16	—	—	14	1.78	1.50	1.21	1.00	0.88	0.82	0.71	0.02~0.12	0.018	<b>AG0.8-20R1</b> <b>AG0.8-20R2</b> <b>AG0.8-30R1</b> <b>AG0.8-30R2</b> <b>AG0.8-40R1</b>				
			14	1.76	1.44	1.11	0.91	0.80	0.74	0.63		0.018					
			18	3.77	3.21	2.62	2.20	1.96	1.81	1.61		0.043					
			18	3.75	3.14	2.46	2.02	1.80	1.65	1.45		0.043					
			22	6.45	5.49	4.55	3.87	3.46	3.19	2.83		0.068					
						26	9.75	8.31	6.94	5.94		5.34		4.96	4.38	0.10	<b>AG0.8-50R1</b>
						30	13.6	11.7	9.77	8.39		7.63		7.05	6.27	0.14	<b>AG0.8-60R1</b>

[NOTE 1] Allowable torque based on worm speed (rpm).

Spur Gears

Helical Gears

Internal Gears

Racks

CP Racks & Pinions

Miter Gears

Bevel Gears

Screw Gears

Worm Gears

Gearboxes

Other Products



# Ground Worm Shafts

Spur Gears

Helical Gears

Internal Gears

Racks

CP Racks & Pinions

Miter Gears

Bevel Gears

Screw Gears

Worm Gears

Gearboxes

Other Products



Specifications	
Precision grade	KHK W 001 grade 2
Reference section of gear	Axial direction
Gear teeth	Standard full depth
Normal pressure angle	20°
Material	SCM440
Heat treatment	Thermal refined, gear teeth induction hardened*
Tooth hardness	50 to 60HRC
Surface treatment	Black oxide coated except for ground part

\* Due to the gear teeth being induction hardened, no secondary operations can be performed on tooth areas including the bottom land (approx. 2 to 3 mm).

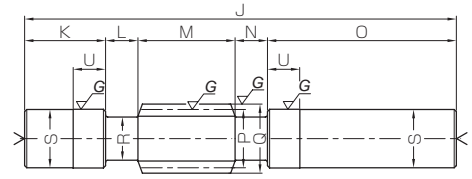

W6

Catalog Number	Axial module	Number of Starts	Nominal lead angle	Direction of helix	Shape	Total Length	Shaft length (L)	Neck length (left)	Face width	Neck length (right)	Shaft length (R)	Pitch dia.
						J	K	L	M	N	O	P
KWG1-R1 KWG1-R2	<b>m1</b>	1 2	3°35' 7°08'	R	W6	140	35	10	30	10	55	16
KWG1.5-R1 KWG1.5-R2	<b>m1.5</b>	1 2	3°26' 6°51'	R	W6	190	50	15	40	15	70	25



# Worm Wheels



Specifications	
Precision grade	KHK W 002 grade 2*
Reference section of gear	Rotating plane
Gear teeth	Standard full depth
Normal pressure angle	20°
Material	CAC702 (old JIS A & BC2)
Heat Treatment	—
Tooth hardness	—

\* The precision grade of J Series products is equivalent to the value shown in the table.

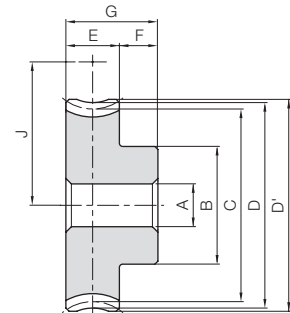

A <sub>H7</sub>	Bore
B	Hub dia.
C	Pitch dia.
D	Throat dia.
D'	Outside dia.
E	Face width
F	Hub width
G	Total length
J	Mounting distance

H1

Catalog Number	Reduction ratio	No. of teeth	No. of starts of mating worm	Lead angle helix direction	Shape	A <sub>H7</sub>	B	C	D	D'	E	F	G	J	Allowable torque (N·m) <small>NOTE 1</small>							Backlash (mm)	Weight (kg)												
															30 rpm	100 rpm	300 rpm	600 rpm	900 rpm	1200 rpm	1800 rpm														
<b>AG1-20R1</b>	20	20	1	3°35'	R H1	6	16	20	22	23	10	10	20	18	3.35	2.79	2.23	1.83	1.63	1.50	1.30	0.04~0.14	0.038												
<b>AG1-20R2</b>	10	20	2	7°08'											3.31	2.69	2.06	1.68	1.48	1.35	1.15														
<b>AG1-30R1</b>	30	30	1	3°35'											6	20	30	32	33	23	7.08			5.98	4.84	4.05	3.63	3.31	2.92						
<b>AG1-30R2</b>	15	30	2	7°08'											6	20	30	32	33	23	7.03			5.84	4.56	3.72	3.33	3.03	2.63						
<b>AG1-40R1</b>	40	40	1	3°35'											8	26	40	42	43	28	12.1			10.2	8.43	7.12	6.38	5.86	5.13						
<b>AG1-50R1</b>	50	50	1	3°35'											8	30	50	52	53	33	18.3			15.5	12.9	10.9	9.87	9.09	7.95						
<b>AG1-60R1</b>	60	60	1	3°35'											10	35	60	62	63	38	25.6			21.8	18.1	15.4	14.1	12.9	11.4						
<b>AG1.5-20R1</b>	20	20	1	3°26'											R H1	8	22	30	33	34.5	14			10	24	27.5	9.84	8.18	6.40	5.30	4.68	4.25	3.68	0.04~0.14	0.10
<b>AG1.5-20R2</b>	10	20	2	6°51'																							9.72	7.87	5.92	4.87	4.25	3.83	3.27		
<b>AG1.5-30R1</b>	30	30	1	3°26'																							10	30	45	48	49.5	35	20.8		
<b>AG1.5-30R2</b>	15	30	2	6°51'	10	30	45	48	49.5	35	20.7	17.1	13.1	10.8								9.56	8.58				7.46								
<b>AG1.5-40R1</b>	40	40	1	3°26'	12	35	60	63	64.5	42.5	35.6	30.0	24.2	20.6								18.3	16.6				14.6								
<b>AG1.5-50R1</b>	50	50	1	3°26'	12	45	75	78	79.5	50	53.8	45.4	36.9	31.6								28.3	25.8				22.6								
<b>AG1.5-60R1</b>	60	60	1	3°26'	12	50	90	93	94.5	57.5	75.3	63.8	51.9	44.7								40.4	36.7				32.4								

[NOTE 1] Allowable torque based on worm speed (rpm).



Outside dia.	Neck dia.	Shaft dia.	Grinding length of shaft	Weight (kg)	Catalog Number
Q	R	S	U		
18	13	18.2	20	0.25	<b>KWG1-R1</b> <b>KWG1-R2</b>
28	21	26.2	20	0.74	<b>KWG1.5-R1</b> <b>KWG1.5-R2</b>

Worm Wheels

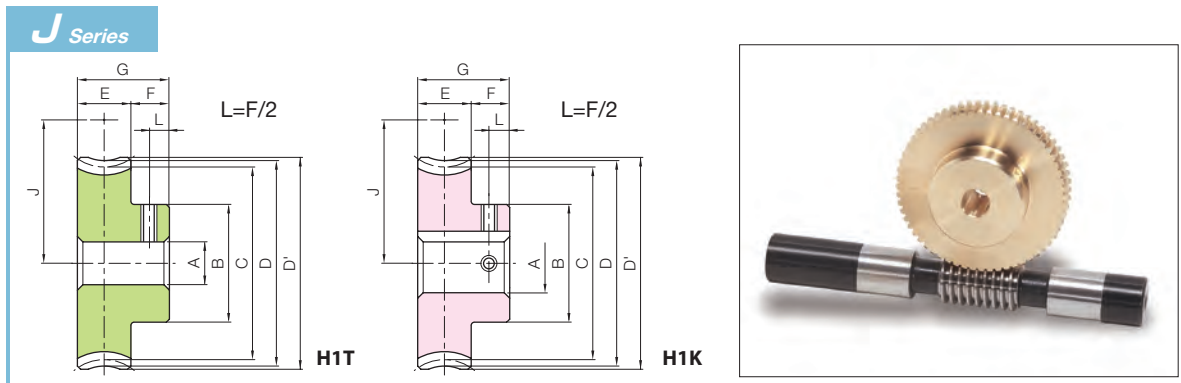

To order J Series products, please specify: **Catalog No. + J + BORE.**

Bore H7	* The product shapes of J Series items are identified by background color.														
	6	8	10	12	14	15	16	17	18	19	20	22	25	28	30
Keyway J <sub>s9</sub>	—		4x1.8			5x2.3			6x2.8			8x3.3			
Screw size	—		4x1.8			5x2.3			6x2.8			8x3.3			
Catalog Number	M4	M5	M4			M5			M6						
AG1-20R1 J BORE															
AG1-20R2 J BORE															
AG1-30R1 J BORE															
AG1-30R2 J BORE															
AG1-40R1 J BORE															
AG1-50R1 J BORE															
AG1-60R1 J BORE															
AG1.5-20R1 J BORE															
AG1.5-20R2 J BORE															
AG1.5-30R1 J BORE															
AG1.5-30R2 J BORE															
AG1.5-40R1 J BORE															
AG1.5-50R1 J BORE															
AG1.5-60R1 J BORE															

[Caution on J series] ① Cancellation is not possible for made-to-order products. See page 42 for lead times and allowable order quantities. See page 44 for other precautions.

Spur Gears

Helical Gears

Internal Gears

Racks

CP Racks & Pinions

Miter Gears

Bevel Gears

Screw Gears

Worm Gears

Gearboxes

Other Products



# Ground Worm Shafts

Spur Gears

Helical Gears

Internal Gears

Racks

CP Racks & Pinions

Miter Gears

Bevel Gears

Screw Gears

Worm Gears

Gearboxes

Other Products



Specifications	
Precision grade	KHK W 001 grade 2
Reference section of gear	Axial direction
Gear teeth	Standard full depth
Normal pressure angle	20°
Material	SCM440
Heat treatment	Thermal refined, gear teeth induction hardened*
Tooth hardness	50 to 60HRC
Surface treatment	Black oxide coated except for ground part

\* Due to the gear teeth being induction hardened, no secondary operations can be performed on tooth areas including the bottom land (approx. 2 to 3 mm).

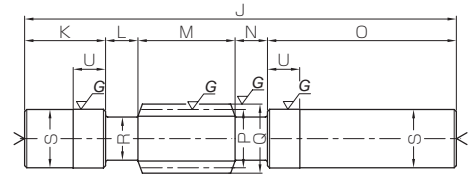

W6

Catalog Number	Axial module	Number of Starts	Nominal lead angle	Direction of helix	Shape	Total Length	Shaft length (L)	Neck length (left)	Face width	Neck length (right)	Shaft length (R)	Pitch dia.
						J	K	L	M	N	O	P
KWG2-R1 KWG2-R2	<b>m2</b>	1 2	5°12' 10°18'	R	W6	200	35	25	40	25	75	22
KWG2.5-R1 KWG2.5-R2	<b>m2.5</b>	1 2	4°46' 9°28'	R	W6	250	50	27	46	27	100	30



# Worm Wheels



Specifications	
Precision grade	KHK W 002 grade 2
Reference section of gear	Rotating plane
Gear teeth	Standard full depth
Normal pressure angle	20°
Material	CAC702 (old JIS A & BC2) *
Heat treatment	—
Tooth hardness	—

\* The hub material of H8 and H9 is FC200.

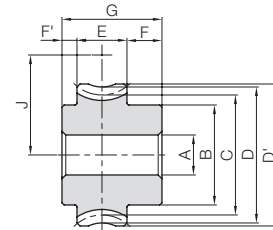

H6

Catalog Number	Reduction ratio	Transverse module	No. of teeth	No. of starts of mating worm	Profile shift coefficient	Lead angle	Direction of helix	Shape	Bore	Hub dia.	Pitch dia.	Throat dia.	Outside dia.	Face width	Hub width (right)	Hub width (left)
									A <sub>H7</sub>	B	C	D	D'	E	F	F'
AGF2-20R1	20	<b>m2</b>	20	1	-0.5	5°12'	R	H6	12	32	40	42	44	18	12	5
AGF2-20R2	10		20	2	-0.5	10°18'										
AGF2-30R1	30		30	1	-0.5	5°12'										
AGF2-30R2	15		30	2	-0.5	10°18'										
AGF2-36R1	36		36	1	0	5°12'										
AGF2-40R1	40		40	1	-0.5	5°12'										
AGF2-50R1	50	50	1	-0.5	5°12'	H9										
AGF2-60R1	60	60	1	-0.5	5°12'	H9										
AGF2.5-20R1	20	<b>m2.5</b>	20	1	0	4°46'	R	H6	12	35	50	55	57.5	20	15	5
AGF2.5-20R2	10		20	2		9°28'										
AGF2.5-30R1	30		30	1		4°46'										
AGF2.5-30R2	15		30	2		9°28'										
AGF2.5-40R1	40		40	1		4°46'										
AGF2.5-50R1	50		50	1		4°46'										
AGF2.5-60R1	60	60	1	4°46'	H9											



\* For products not categorized in our KHK Stock Gear series, custom gear production services with short lead times are available. Please see Page 26 for more details about custom-made orders.

Outside dia.	Neck dia.	Shaft dia.	Grinding length of shaft	Weight (kg)	Catalog Number
Q	R	S	U		
26	17	25.2	20	0.64	<b>KWG2-R1</b> <b>KWG2-R2</b>
35	23	30.2	20	1.27	<b>KWG2.5-R1</b> <b>KWG2.5-R2</b>

Worm Wheels

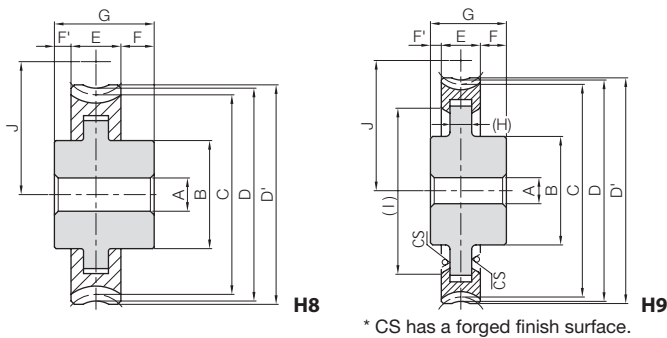

Total length	Web thickness	Web O.D.	Mounting distance	Allowable torque (N·m) <small>NOTE 1</small>							Backlash (mm)	Weight (kg)	Catalog Number
				30 rpm	100 rpm	300 rpm	600 rpm	900 rpm	1200 rpm	1800 rpm			
G	(H)	(I)	J										
35	—	—	30	19.4	16.1	12.8	10.5	9.30	8.49	7.31	0.06~0.16	0.25	<b>AGF2-20R1</b>
			30	19.9	16.1	12.2	9.99	8.75	7.92	6.74		0.25	<b>AGF2-20R2</b>
			40	41.1	34.5	27.7	23.2	20.7	18.8	16.4		0.51	<b>AGF2-30R1</b>
			40	42.3	35.0	27.0	22.1	19.9	17.7	15.4		0.51	<b>AGF2-30R2</b>
			47	57.8	48.6	39.3	33.2	29.6	27.0	23.6		0.73	<b>AGF2-36R1</b>
	50	70.3	59.2	48.1	40.7	36.4	33.2	28.9	0.85	<b>AGF2-40R1</b>			
40	—	—	60	106	89.5	73.4	62.5	56.2	51.5	44.9	0.06~0.16	1.14	<b>AGF2-50R1</b>
			70	149	126	103	88.4	80.3	73.3	64.2		1.51	<b>AGF2-60R1</b>
			40	35.1	29.0	22.6	18.6	16.3	14.8	12.8		0.44	<b>AGF2.5-20R1</b>
			40	34.6	27.9	20.9	17.1	14.8	13.4	11.3		0.44	<b>AGF2.5-20R2</b>
			52.5	74.1	62.0	49.1	41.2	36.7	32.8	28.7		0.87	<b>AGF2.5-30R1</b>
	52.5	73.6	60.6	46.2	37.8	33.2	29.9	25.8	0.87	<b>AGF2.5-30R2</b>			
40	(13)	(100)	65	127	106	85.4	72.4	63.7	57.9	50.5	0.06~0.16	1.42	<b>AGF2.5-40R1</b>
			77.5	192	161	130	111	98.4	90.0	78.3		1.92	<b>AGF2.5-50R1</b>
			90	268	226	183	157	141	128	112		2.59	<b>AGF2.5-60R1</b>

[NOTE 1] Allowable torque based on worm speed (rpm).



# Ground Worm Shafts

- Spur Gears
- Helical Gears
- Internal Gears
- Racks
- CP Racks & Pinions
- Miter Gears
- Bevel Gears
- Screw Gears
- Worm Gears
- Gearboxes
- Other Products



Specifications	
Precision grade	KHK W 001 grade 2
Reference section of gear	Axial direction
Gear teeth	Standard full depth
Normal pressure angle	20°
Material	SCM440
Heat treatment	Thermal refined, gear teeth induction hardened*
Tooth hardness	50 to 60HRC
Surface treatment	Black oxide coated except for ground part

\* Due to the gear teeth being induction hardened, no secondary operations can be performed on tooth areas including the bottom land (approx. 2 to 3 mm).

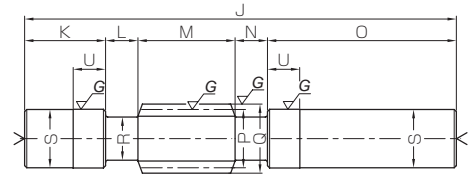

W6

Catalog Number	Axial module	Number of Starts	Nominal lead angle	Direction of helix	Shape	Total Length	Shaft length (L)	Neck length (left)	Face width	Neck length (right)	Shaft length (R)	Pitch dia.
						J	K	L	M	N	O	P
KWG3-R1 KWG3-R2	<b>m3</b>	1 2	4°31' 8°58'	R	W6	300	55	30	60	30	125	38
KWG4-R1 KWG4-R2	<b>m4</b>	1 2	5°43' 11°19'	R	W6	360	70	32.5	75	32.5	150	40



# Worm Wheels



Specifications	
Precision grade	KHK W 002 grade 2
Reference section of gear	Rotating plane
Gear teeth	Standard full depth
Normal pressure angle	20°
Material	CAC702 (old JIS A ̢ BC2) *
Heat treatment	—
Tooth hardness	—

\* The hub material of H8 and H9 is FC200.

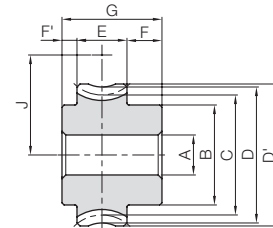

H6

Catalog Number	Reduction ratio	Transverse module	No. of teeth	No. of starts of mating worm	Profile shift coefficient	Lead angle	Direction of helix	Shape	Bore	Hub dia.	Pitch dia.	Throat dia.	Outside dia.	Face width	Hub width (right)	Hub width (left)										
									A <sub>H7</sub>	B	C	D	D'	E	F	F'										
AGF3-20R1 AGF3-20R2 AGF3-25R1 AGF3-30R1 AGF3-40R1	20 10 25 30 40	<b>m3</b>	20 20 25 30 40	1 2 1 1 1	+0.333 +0.333 0 +0.333 +0.333	4°31' 8°58' 4°31' 4°31' 4°31'	R	H6 H6 H6 H8 H8	20	50 50 55 55 65	60 60 75 90 120	68 68 81 98 128	71 71 84 101 131	25	17.5	7.5										
AGF3-50R1 AGF3-60R1	50 60		50 60	1	+0.333	4°31'				H9 H9	75 80	150 180	158 188				161 191									
AGF4-20R1 AGF4-20R2 AGF4-25R1 AGF4-30R1 AGF4-30R2	20 10 25 30 15		<b>m4</b>	20 20 25 30 30	1 2 1 1 2	— — — 0 0				5°43' 11°19' 5°43' 5°43' 11°19'	R	H6 H6 H6 H8 H8	20				60 60 65 65 65	80 80 100 120 120	88 88 108 128 128	92 92 112 132 132	30	20	10			
AGF4-40R1 AGF4-50R1 AGF4-60R1	40 50 60			40 50 60	1	—				5°43'							H9 H9 H0	20 20 160	80 90 —	168 208 248				172 212 252	20 20 7	10 10 15

[Caution on Product Characteristics] ① For H0 products with bore of  $\phi$  190 or larger, the bore tolerance is H8.



\* For products not categorized in our KHK Stock Gear series, custom gear production services with short lead times are available. Please see Page 26 for more details about custom-made orders.

Outside dia.	Neck dia.	Shaft dia.	Grinding length of shaft	Weight (kg)	Catalog Number
Q	R	S	U		
44	30	40.2	25	2.66	<b>KWG3-R1</b> <b>KWG3-R2</b>
48	29	45.2	25	3.85	<b>KWG4-R1</b> <b>KWG4-R2</b>

Worm Wheels

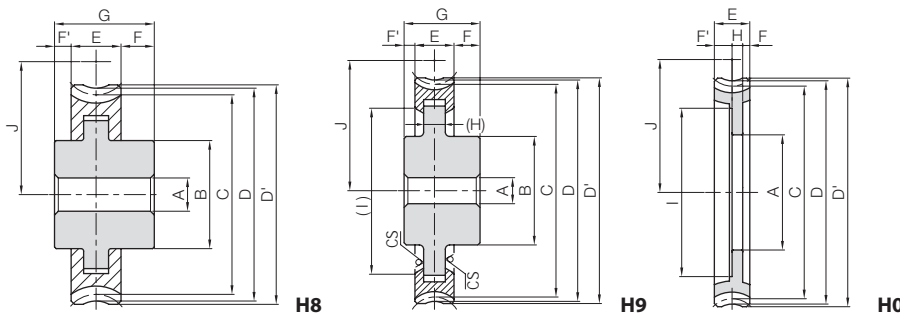

\* CS has a forged finish surface.



Total length	Web thickness	Web O.D.	Mounting distance	Allowable torque (N·m) <small>NOTE 1</small>								Backlash (mm)	Weight (kg)	Catalog Number
				30 rpm	100 rpm	300 rpm	600 rpm	900 rpm	1200 rpm	1800 rpm				
G	(H)	(I)	J											
50	—	—	50	59.7	49.1	38.3	31.5	27.5	25.1	21.5	0.06~0.16	0.88	<b>AGF3-20R1</b> <b>AGF3-20R2</b> <b>AGF3-25R1</b> <b>AGF3-30R1</b> <b>AGF3-40R1</b>	
			50	60.2	48.2	36.1	29.5	25.4	23.0	19.4		0.88		
			56.5	90.2	74.3	58.8	48.9	42.6	39.0	33.5		1.24		
			65	126	105	83.1	69.6	61.0	55.4	48.2		1.63		
			80	216	180	145	122	108	98.0	84.9		2.76		
			(15)	(125)	95	326	272	220	188	166		152		132
(15)	(155)	110	457	383	310	265	237	217	188	4.76				
60	—	—	60	123	101	78.8	64.6	56.3	51.5	43.8	0.06~0.16	1.77	<b>AGF4-20R1</b> <b>AGF4-20R2</b> <b>AGF4-25R1</b> <b>AGF4-30R1</b> <b>AGF4-30R2</b>	
			60	127	101	76.0	61.9	53.2	48.3	40.5		1.77		
			70	186	153	121	100	87.3	79.9	68.5		2.56		
			80	260	216	171	143	125	114	98.4		3.28		
			80	270	220	168	137	120	108	92.2		3.28		
60	(20)	(128)	100	445	370	297	251	220	201	173	5.25	<b>AGF4-40R1</b> <b>AGF4-50R1</b> <b>AGF4-60R1</b>		
60	(20)	(168)	120	673	560	454	385	340	312	269	7.35			
30	8	204	140	941	788	638	544	486	444	385	3.60			

[NOTE 1] Allowable torque based on worm speed (rpm).



# Ground Worm Shafts

Spur Gears

Helical Gears

Internal Gears

Racks

CP Racks & Pinions

Miter Gears

Bevel Gears

Screw Gears

Worm Gears

Gearboxes

Other Products



Specifications	
Precision grade	KHK W 001 grade 2
Reference section of gear	Axial direction
Gear teeth	Standard full depth
Normal pressure angle	20°
Material	SCM440
Heat treatment	Thermal refined, gear teeth induction hardened*
Tooth hardness	50 to 60HRC
Surface treatment	Black oxide coated except for ground part

\* Due to the gear teeth being induction hardened, no secondary operations can be performed on tooth areas including the bottom land (approx. 2 to 3 mm).

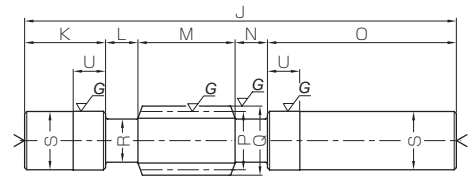

W6

Catalog Number	Axial module	Number of Starts	Nominal lead angle	Direction of helix	Shape	Total Length	Shaft length (L)	Neck length (left)	Face width	Neck length (right)	Shaft length (R)	Pitch dia.
						J	K	L	M	N	O	P
<b>KWG5-R1</b>	<b>m5</b>	1	5°43'	R	W6	400	75	30	90	30	175	50
<b>KWG6-R1</b>	<b>m6</b>	1	5°43'	R	W6	400	60	40	100	40	160	60



# Worm Wheels

CP Racks & Pinions

Miter Gears

Bevel Gears

Screw Gears

Worm Gears



Specifications	
Precision grade	KHK W 002 grade 2
Reference section of gear	Rotating plane
Gear teeth	Standard full depth
Normal pressure angle	20°
Material	CAC702 (old JIS A & BC2) *
Heat treatment	—
Tooth hardness	—

\* The hub material of H8 and H9 is FC200.

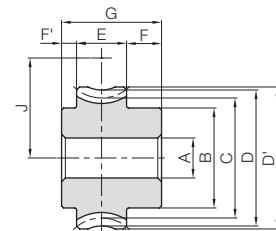

H6

Catalog Number	Reduction ratio	Transverse module	No. of teeth	No. of starts of mating worm	Profile shift coefficient	Lead angle	Direction of helix	Shape	Bore	Hub dia.	Pitch dia.	Throat dia.	Outside dia.	Face width	Hub width (right)	Hub width (left)
									AH7	B	C	D	D'	E	F	F'
<b>AGF5-20R1</b>	20	<b>m5</b>	20	1	0	5°43'	R	H6	22	75	100	110	115	35	23	12
<b>AGF5-30R1</b>	30		75					150		160	165					
<b>AGF5-40R1</b>	40		110					200		210	215					
<b>AGF5-50R1</b>	50		—					250	260	265	7.5	17.5				
<b>AGF5-60R1</b>	60							200	300	310			315			
<b>AGF6-20R1</b>	20	<b>m6</b>	20	1	0	5°43'	R	H6	25	85	120	132	138	40	23	12
<b>AGF6-30R1</b>	30		100					180		192	198					
<b>AGF6-40R1</b>	40		—					240	252	258	8	20				
<b>AGF6-50R1</b>	50							300	312	318						
<b>AGF6-60R1</b>	60							250	360	372			378			

[Caution on Product Characteristics] ① For H0 products with bore of  $\phi$  190 or larger, the bore tolerance is H8.



\* For products not categorized in our KHK Stock Gear series, custom gear production services with short lead times are available. Please see Page 26 for more details about custom-made orders.

Outside dia.	Neck dia.	Shaft dia.	Grinding length of shaft	Weight (kg)	Catalog Number
Q	R	S	U		
60	36	50.2	30	5.75	<b>KWG5-R1</b>
72	44	60.2	30	8.09	<b>KWG6-R1</b>

Worm Wheels

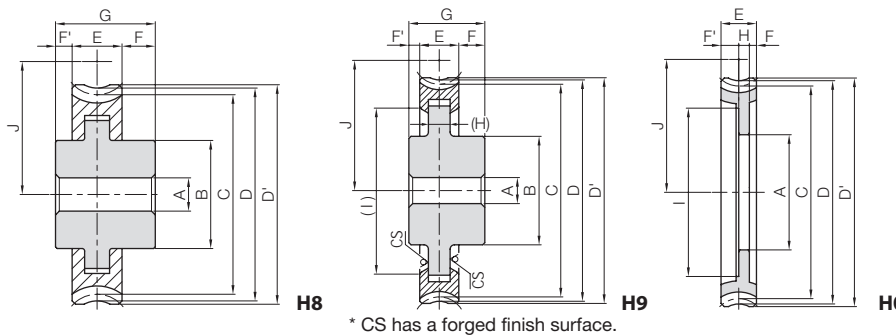

Total length G	Web thickness (H)	Web O.D. (I)	Mounting distance J	Allowable torque (N·m) <small>NOTE 1</small>							Backlash (mm)	Weight (kg)	Catalog Number
				30 rpm	100 rpm	300 rpm	600 rpm	900 rpm	1200 rpm	1800 rpm			
70	— (26)	— (162)	75	211	172	134	108	95.0	86.2	72.7	0.07~0.19	3.26	<b>AGF5-20R1</b>
			100	446	369	291	239	211	191	164		5.79	<b>AGF5-30R1</b>
			125	763	632	506	421	371	337	288		9.97	<b>AGF5-40R1</b>
35	10	205 255	150	1150	956	772	646	574	523	446	0.07~0.19	5.28	<b>AGF5-50R1</b>
			175	1610	1340	1090	913	820	744	639		6.48	<b>AGF5-60R1</b>
75	—	—	90	329	268	208	167	146	131	110	0.07~0.19	4.95	<b>AGF6-20R1</b>
			120	696	572	451	368	325	290	248		9.66	<b>AGF6-30R1</b>
			150	1190	981	784	648	572	513	436		6.20	<b>AGF6-40R1</b>
40	12	190 250 310	180	1800	1480	1200	994	885	796	676	0.07~0.19	8.00	<b>AGF6-50R1</b>
			210	2520	2090	1680	1410	1260	1130	969		10.0	<b>AGF6-60R1</b>

[NOTE 1] Allowable torque based on worm speed (rpm).

Spur Gears

Helical Gears

Internal Gears

Racks

CP Racks & Pinions

Miter Gears

Bevel Gears

Screw Gears

Worm Gears

Gearboxes

Other Products



# SWG Module 1, 1.5 Ground Worms



Specifications	
Precision grade	KHK W 001 grade 2*
Reference section of gear	Axial direction
Gear teeth	Standard full depth
Normal pressure angle	20°
Material	S45C
Heat treatment	Gear teeth induction hardened**
Tooth hardness	50 to 60HRC
Surface treatment	Black oxide coated except for ground part

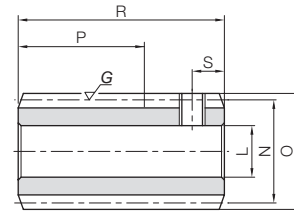

W2

\* The precision grade of J Series products is equivalent to the value shown in the table.

\*\* Due to the gear teeth being induction hardened, no secondary operations can be performed on tooth areas including the bottom land (approx. 2 to 3 mm).

Catalog Number ● : J Series (Available-on-request)	Axial module	Number of Starts	Nominal lead angle	Direction of helix	Shape	Bore		Pitch dia.	Outside dia.	Face width	Hub width (right)	Hub width (left)
						L <sub>H7</sub>	M					
SWG1-R1 SWG1-R2	m1	1 2	3°35' 7°08'	R	W2	8	—	16	18	(20)	—	—
SWG1.5-R1 ● SWG1.5-R1J10	m1.5	1	3°26'	R	W1 W1K	10	20	25	28	30	10	—
SWG1.5-R2 ● SWG1.5-R2J10		2	6°51'		W1 W1K							

[Caution on J series] ① Cancellation is not possible for made-to-order products. See page 42 for lead times and allowable order quantities. See page 44 for other precautions.



# AG Module 1, 1.5 Worm Wheels



Specifications	
Precision grade	KHK W 002 grade 2*
Reference section of gear	Rotating plane
Gear teeth	Standard full depth
Normal pressure angle	20°
Material	CAC702 (old JIS A ̢ BC2)
Heat Treatment	—
Tooth hardness	—

A <sub>H7</sub>	Bore
B	Hub dia.
C	Pitch dia.
D	Throat dia.
D'	Outside dia.
E	Face width
F	Hub width
G	Total length
J	Mounting distance

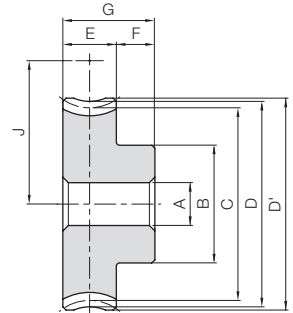

H1

\* The precision grade of J Series products is equivalent to the value shown in the table.

Catalog Number	Reduction ratio	No. of teeth	No. of starts of mating worm	Lead angle helix direction	Shape	A <sub>H7</sub>	B	C	D	D'	E	F	G	J	Allowable torque (N·m) <small>NOTE 1</small>							Backlash (mm)	Weight (kg)	
															30 rpm	100 rpm	300 rpm	600 rpm	900 rpm	1200 rpm	1800 rpm			
AG1-20R1	20	20	1	3°35'	R H1	6	16	20	22	23	10	10	20	18	3.35	2.79	2.23	1.83	1.63	1.50	1.30	0.04~0.14	0.038	
AG1-20R2	10	20	2	7°08'		6	16	20	22	23														
AG1-30R1	30	30	1	3°35'		6	20	30	32	33														
AG1-30R2	15	30	2	7°08'		6	20	30	32	33														
AG1-40R1	40	40	1	3°35'		8	26	40	42	43														
AG1-50R1	50	50	1	3°35'		8	30	50	52	53														
AG1-60R1	60	60	1	3°35'		10	35	60	62	63														
AG1.5-20R1	20	20	1	3°26'		R H1	8	22	30	33	34.5	14	10	24	27.5	9.84	8.18	6.40	5.30	4.68	4.25	3.68	0.04~0.14	0.10
AG1.5-20R2	10	20	2	6°51'			8	22	30	33	34.5													
AG1.5-30R1	30	30	1	3°26'			10	30	45	48	49.5													
AG1.5-30R2	15	30	2	6°51'			10	30	45	48	49.5													
AG1.5-40R1	40	40	1	3°26'			12	35	60	63	64.5													
AG1.5-50R1	50	50	1	3°26'	12		45	75	78	79.5														
AG1.5-60R1	60	60	1	3°26'	12		50	90	93	94.5														

[NOTE 1] Allowable torque based on worm speed (rpm).



J Series

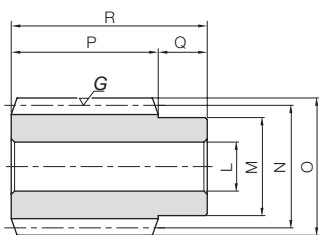

W1

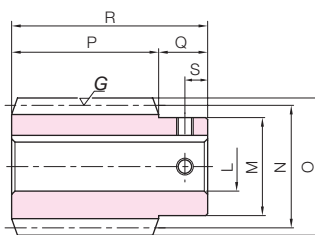

W1K



Total length R	Keyway Width x Depth	Socket head screw		Weight (kg)	Catalog Number ● : J Series (Available-on-request)
		Size	S		
32	—	M4	5	0.037	SWG1-R1 SWG1-R2
40	—	—	—	0.12	SWG1.5-R1
	4 x 1.8	M4	5	0.11	● SWG1.5-R1J10
	—	—	—	0.12	SWG1.5-R2
	4 x 1.8	M4	5	0.11	● SWG1.5-R2J10



Worm Wheels

J Series

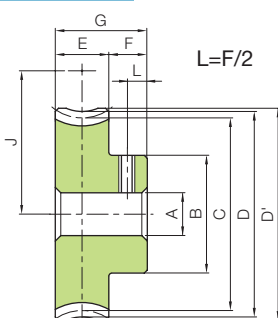

H1T

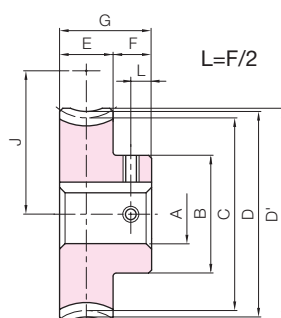

H1K



To order J Series products, please specify: **Catalog No. + J + BORE.**

Bore H7	* The product shapes of J Series items are identified by background color.																																											
	6	8	10	12	14	15	16	17	18	19	20	22	25	28	30																													
Keyway JS9	6		8			10			12			14			15			16			17			18			19			20			22			25			28			30		
Screw size	—		4x1.8			5x2.3			6x2.8			8x3.3																																
Catalog Number	M4		M5			M4			M5			M6																																
AG1-20R1 J BORE																																												
AG1-20R2 J BORE																																												
AG1-30R1 J BORE																																												
AG1-30R2 J BORE																																												
AG1-40R1 J BORE																																												
AG1-50R1 J BORE																																												
AG1-60R1 J BORE																																												
AG1.5-20R1 J BORE																																												
AG1.5-20R2 J BORE																																												
AG1.5-30R1 J BORE																																												
AG1.5-30R2 J BORE																																												
AG1.5-40R1 J BORE																																												
AG1.5-50R1 J BORE																																												
AG1.5-60R1 J BORE																																												

[Caution on J series] ① Cancellation is not possible for made-to-order products. See page 42 for lead times and allowable order quantities. See page 44 for other precautions.

Spur Gears

Helical Gears

Internal Gears

Racks

CP Racks & Pinions

Miter Gears

Bevel Gears

Screw Gears

Worm Gears

Gearboxes

Other Products



# SWG Module 2, 2.5 Ground Worms



Specifications	
Precision grade	KHK W 001 grade 2*
Reference section of gear	Axial direction
Gear teeth	Standard full depth
Normal pressure angle	20°
Material	S45C
Heat treatment	Gear teeth induction hardened**
Tooth hardness	50 to 60HRC
Surface treatment	Black oxide coated except for ground part

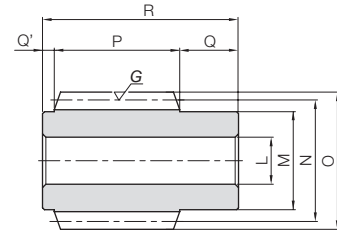

W3

\* The precision grade of J Series products is equivalent to the value shown in the table.

\*\* Due to the gear teeth being induction hardened, no secondary operations can be performed on tooth areas including the bottom land (approx. 2 to 3 mm).

Catalog Number ● : J Series (Available-on-request)	Axial module	Number of Starts	Nominal lead angle	Direction of helix	Shape	Bore	Hub dia.	Pitch dia.	Outside dia.	Face width	Hub width (right)	Hub width (left)
						LH7	M	N	O	P	Q	Q'
<b>SWG2-R1</b> ● <b>SWG2-R1J12</b> ● <b>SWG2-R1J14</b>	m2	1	3°41'	R	W3	12	25	31	35	32	15	3
W3K		12										
W3K	14											
<b>SWG2-R2</b> ● <b>SWG2-R2J12</b> ● <b>SWG2-R2J14</b>	m2	2	7°21'	R	W3	12	25	31	35	32	15	3
W3K		12										
W3K	14											
<b>SWG2.5-R1</b> ● <b>SWG2.5-R1J15</b> ● <b>SWG2.5-R1J16</b> ● <b>SWG2.5-R1J17</b>	m2.5	1	3°52'	R	W3	15	30	37	42	45	17	3
W3K		15										
W3K	16											
W3K	17											
<b>SWG2.5-R2</b> ● <b>SWG2.5-R2J15</b> ● <b>SWG2.5-R2J16</b> ● <b>SWG2.5-R2J17</b>	m2.5	2	7°42'	R	W3	15	30	37	42	45	17	3
W3K		15										
W3K	16											
W3K	17											

[Caution on J series] ① Cancellation is not possible for made-to-order products. See page 42 for lead times and allowable order quantities. See page 44 for other precautions.



# AG Module 2, 2.5 Worm Wheels



Specifications	
Precision grade	KHK W 002 grade 2*
Reference section of gear	Rotating plane
Gear teeth	Standard full depth
Normal pressure angle	20°
Material	CAC702 (old JIS A & BC2)**
Heat treatment	—
Tooth hardness	—

\* The precision grade of J Series products is equivalent to the value shown in the table.

\*\* The hub material of H4 and H5 is FC200.

A <sub>H7</sub>	Bore
B	Hub dia.
C	Pitch dia.
D	Throat dia.
D'	Outside dia.
E	Face width
F	Hub width
G	Total length
(H)	Web thickness
(I)	Web O.D.
J	Mounting distance

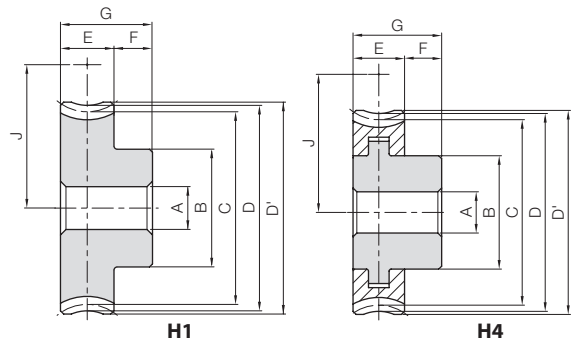

H1

H4

Catalog Number	Reduction ratio	No. of teeth	No. of starts of mating worm	Lead angle helix direction	Shape	A <sub>H7</sub>	B	C	D	D'	E	F	G	(H)	(I)	J	Allowable torque (N·m) <small>NOTE 1</small>							Backlash (mm)	Weight (kg)			
																	30 rpm	100 rpm	300 rpm	600 rpm	900 rpm	1200 rpm	1800 rpm					
<b>AG2-20R1</b>	20	20	1	3°41'	H1		33	40	44	46							35.5	21.0	17.5	13.6	11.2	9.84	8.94	7.75	0.06~0.16	0.26		
<b>AG2-20R2</b>	10	20	2	7°21'	H1		33	40	44	46							35.5	20.7	16.8	12.6	10.3	8.93	8.05	6.89				
<b>AG2-30R1</b>	30	30	1	3°41'	H4		40	60	64	66							45.5	44.3	37.3	29.6	24.8	21.9	19.8	17.4				
<b>AG2-30R2</b>	15	30	2	7°21'	H4	12	40	60	64	66	18	15	33				45.5	44.0	36.5	27.8	22.8	20.1	18.0	15.7				
<b>AG2-40R1</b>	40	40	1	3°41'	H4		45	80	84	86							55.5	75.8	64.0	51.4	43.6	38.5	34.9	30.7	0.85	0.85		
<b>AG2-50R1</b>	50	50	1	3°41'	H5		50	100	104	106							(8)	(83)	65.5	115	96.8	78.4	66.9	59.5	54.2	47.6	1.05	1.05
<b>AG2-60R1</b>	60	60	1	3°41'	H5		55	120	124	126							(11)	(100)	75.5	160	136	110	94.6	84.9	77.2	68.1	1.52	1.52
<b>AG2.5-20R1</b>	20	20	1	3°52'	H1	12	35	50	55	57.5							—	—	43.5	34.6	28.5	22.3	18.3	16.0	14.6	12.5	0.39	0.39
<b>AG2.5-20R2</b>	10	20	2	7°42'	H1	12	35	50	55	57.5							—	—	43.5	34.2	27.4	20.6	16.8	14.5	13.1	11.1	0.39	0.39
<b>AG2.5-30R1</b>	30	30	1	3°52'	H4	12	40	75	80	82.5							—	—	56	73.2	61.0	48.3	40.5	35.5	32.2	28.1	0.79	0.79
<b>AG2.5-30R2</b>	15	30	2	7°42'	H4	12	40	75	80	82.5	20	14	34				—	—	56	72.7	59.6	45.5	37.2	32.6	29.4	25.3	0.79	0.79
<b>AG2.5-40R1</b>	40	40	1	3°52'	H5	15	45	100	105	107.5							(11)	(81)	68.5	125	105	84.0	71.2	62.5	57.0	49.5	1.11	1.11
<b>AG2.5-50R1</b>	50	50	1	3°52'	H5	15	55	125	130	132.5							(12)	(106)	81	189	158	128	109	96.7	88.5	76.7	1.70	1.70
<b>AG2.5-60R1</b>	60	60	1	3°52'	H5	15	60	150	155	157.5							(12)	(130)	93.5	265	222	180	154	138	126	110	2.32	2.32

[NOTE 1] Allowable torque based on worm speed (rpm).



J Series

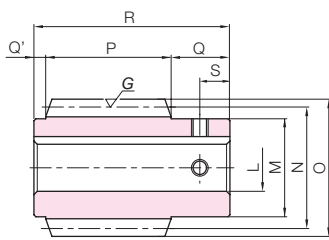

W3K



Total length R	Keyway Width x Depth	Socket head screw		Weight (kg)	Catalog Number ● : J Series (Available-on-request)
		Size	S		
50	—	—	—	0.21	SWG2-R1
	4 x 1.8	M4	7.5	0.21	● SWG2-R1J12
	5 x 2.3	M4	7.5	0.19	● SWG2-R1J14
	—	—	—	0.21	SWG2-R2
	4 x 1.8	M4	7.5	0.21	● SWG2-R2J12
	5 x 2.3	M4	7.5	0.19	● SWG2-R2J14
65	5 x 2.3	M4	8.5	0.40	SWG2.5-R1
	5 x 2.3	M4	8.5	0.39	● SWG2.5-R1J15
	5 x 2.3	M4	8.5	0.38	● SWG2.5-R1J16
	5 x 2.3	M4	8.5	0.37	● SWG2.5-R1J17
	—	—	—	0.40	SWG2.5-R2
	5 x 2.3	M4	8.5	0.39	● SWG2.5-R2J15
	5 x 2.3	M4	8.5	0.38	● SWG2.5-R2J16
	5 x 2.3	M4	8.5	0.37	● SWG2.5-R2J17

Spur Gears

Helical Gears

Internal Gears

Racks

CP Racks & Pinions

Miter Gears

Bevel Gears

Screw Gears

Worm Gears

Gearboxes

Other Products

Worm Wheels

J Series

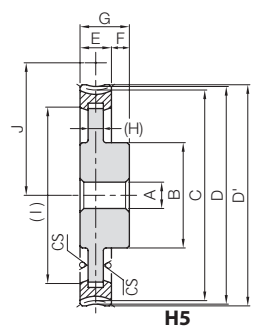

H5

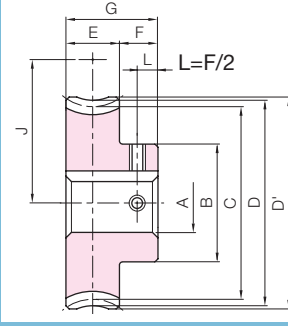

H1K

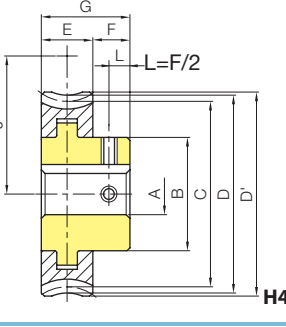

H4K

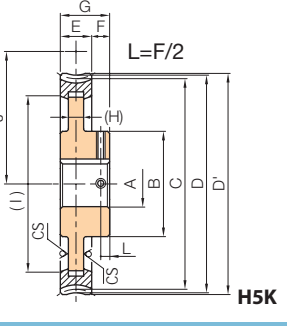

H5K

To order J Series products, please specify: **Catalog No. + J + BORE.**

Bore H7	* The product shapes of J Series items are identified by background color.													
Keyway JS9	12	14	15	16	17	18	19	20	22	25	28	30	32	35
Screw size	4x1.8	5x2.3					6x2.8				8x3.3		10x3.3	
Catalog Number	M4					M5				M6		M8		
AG2-20R1 J BORE														
AG2-20R2 J BORE														
AG2-30R1 J BORE														
AG2-30R2 J BORE														
AG2-40R1 J BORE														
AG2-50R1 J BORE														
AG2-60R1 J BORE														
AG2.5-20R1 BORE														
AG2.5-20R2 BORE														
AG2.5-30R1 BORE														
AG2.5-30R2 BORE														
AG2.5-40R1 BORE														
AG2.5-50R1 BORE														
AG2.5-60R1 BORE														

[Caution on J series] ① Cancellation is not possible for made-to-order products. See page 42 for lead times and allowable order quantities. See page 44 for other precautions.



# SWG Module 3, 4 Ground Worms



Specifications	
Precision grade	KHK W 001 grade 2*
Reference section of gear	Axial direction
Gear teeth	Standard full depth
Normal pressure angle	20°
Material	S45C
Heat treatment	Gear teeth induction hardened**
Tooth hardness	50 to 60HRC
Surface treatment	Black oxide coated except for ground part

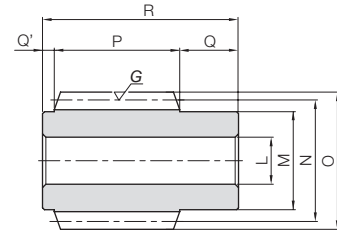

W3

\* The precision grade of J Series products is equivalent to the value shown in the table.

\*\* Due to the gear teeth being induction hardened, no secondary operations can be performed on tooth areas including the bottom land (approx. 2 to 3 mm).

Catalog Number ● : J Series (Available-on-request)	Axial module	Number of Starts	Nominal lead angle	Direction of helix	Shape	Bore		Hub dia.	Pitch dia.	Outside dia.	Face width	Hub width (right)	Hub width (left)
						LH7	M						
<b>SWG3-R1</b> ● <b>SWG3-R1J17</b> ● <b>SWG3-R1J18</b> ● <b>SWG3-R1J19</b> ● <b>SWG3-R1J20</b>	m3	1	3°54'	R	W3	16	35	44	50	50	20	4	
W3K					17								
● <b>SWG3-R2J17</b> ● <b>SWG3-R2J18</b> ● <b>SWG3-R2J19</b> ● <b>SWG3-R2J20</b>	m3	2	7°46'	R	W3	16	35	44	50	50	20	4	
					W3K	17							
<b>SWG4-R1</b> <b>SWG4-R2</b>	m4	1	3°41'	R	W3	22	50	62	70	70	25	5	
													2

[Caution on J series] ① Cancellation is not possible for made-to-order products. See page 42 for lead times and allowable order quantities. See page 44 for other precautions.



# AG Module 3, 4 Worm Wheels



Specifications	
Precision grade	KHK W 002 grade 2*
Reference section of gear	Rotating plane
Gear teeth	Standard full depth
Normal pressure angle	20°
Material	CAC702 (old JIS A 8 BC2) **
Heat treatment	—
Tooth hardness	—

\* The precision grade of J Series products is equivalent to the value shown in the table.

\*\* The hub material of H4 and H5 is FC200.

A <sub>H7</sub>	Bore
B	Hub dia.
C	Pitch dia.
D	Throat dia.
D'	Outside dia.
E	Face width
F	Hub width
G	Total length
(H)	Web thickness
(I)	Web O.D.
J	Mounting distance

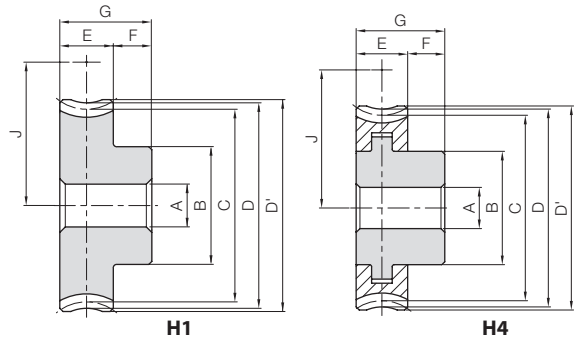

Catalog Number	Reduction ratio	No. of teeth	No. of starts of mating worm	Lead angle helix direction	Shape	A <sub>H7</sub>	B	C	D	D'	E	F	G	(H)	(I)	J	Allowable torque (N·m) <small>NOTE 1</small>							Backlash (mm)	Weight (kg)
																	30 rpm	100 rpm	300 rpm	600 rpm	900 rpm	1200 rpm	1800 rpm		
<b>AG3-20R1</b>	20	20	1	3°54'	H1	20	50	60	66	69	25	18	43	—	—	52	59.5	48.8	38.0	30.9	27.0	24.7	20.9	0.75	
<b>AG3-20R2</b>	10	20	2	7°46'	H1		50	60	66	69															—
<b>AG3-30R1</b>	30	30	1	3°54'	H4	20	55	90	96	99	25	18	43	—	—	67	126	104.3	82.4	68.4	59.9	54.5	46.9	1.46	
<b>AG3-30R2</b>	15	30	2	7°46'	H4		55	90	96	99															—
<b>AG3-40R1</b>	40	40	1	3°54'	H5	20	65	120	126	129	25	18	43	(10)	(103)	82	215	179	143	120	106	96.4	82.5	2.03	
<b>AG3-50R1</b>	50	50	1	3°54'	H5		75	150	156	159															(15)
<b>AG3-60R1</b>	60	60	1	3°54'	H5	20	85	180	186	189	25	18	43	(15)	(155)	112	455	380	308	261	233	213	183	4.52	
<b>AG4-20R1</b>	20	20	1	3°41'	H1		60	80	88	92															30
<b>AG4-20R2</b>	10	20	2	7°21'	H1	60	80	88	92	—	—	71	114	90.0	67.2	53.5	46.4	41.2	34.1						
<b>AG4-30R1</b>	30	30	1	3°41'	H4	20	65	120	128	132	30	20	50	—	—	91	244	200	158	129	114	101	86.3	3.00	
<b>AG4-30R2</b>	15	30	2	7°21'	H4		65	120	128	132															—
<b>AG4-40R1</b>	40	40	1	3°41'	H5	20	80	160	168	172	30	20	50	(15)	(133)	111	417	343	274	226	200	179	152	4.32	
<b>AG4-50R1</b>	50	50	1	3°41'	H5		90	200	208	212															(16)
<b>AG4-60R1</b>	60	60	1	3°41'	H5	20	100	240	248	252	30	20	50	(17)	(210)	151	881	730	589	491	441	395	337	8.74	

[NOTE 1] Allowable torque based on worm speed (rpm).



J Series

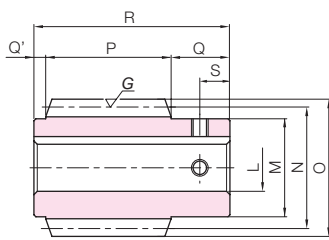

W3K



Total length R	Keyway Width × Depth	Socket head screw		Weight (kg)	Catalog Number ● : J Series (Available-on-request)
		Size	S		
74	—	—	—	0.66	SWG3-R1
	5 × 2.3	M4	10	0.64	● SWG3-R1J17
	6 × 2.8	M5	10	0.62	● SWG3-R1J18
	6 × 2.8	M5	10	0.60	● SWG3-R1J19
	6 × 2.8	M5	10	0.58	● SWG3-R1J20
	—	—	—	0.66	SWG3-R2
	5 × 2.3	M4	10	0.64	● SWG3-R2J17
	6 × 2.8	M5	10	0.62	● SWG3-R2J18
	6 × 2.8	M5	10	0.60	● SWG3-R2J19
	6 × 2.8	M5	10	0.58	● SWG3-R2J20
100	—	—	—	1.82	SWG4-R1 SWG4-R2

Spur Gears

Helical Gears

Internal Gears

Racks

CP Racks & Pinions

Miter Gears

Worm Wheels

J Series

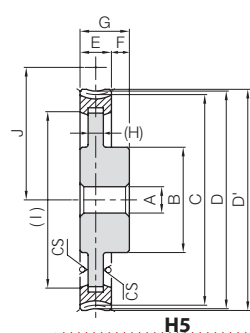

H5

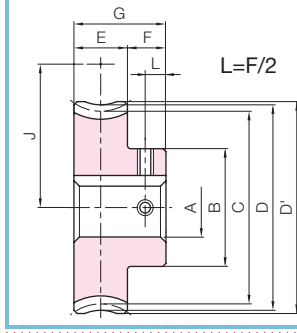

H1K

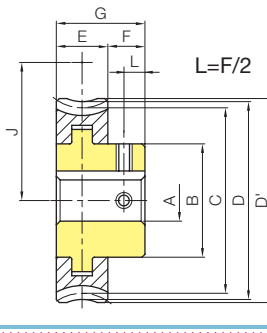

H4K

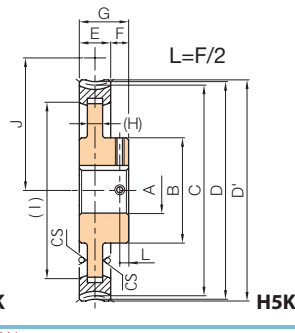

H5K

Bevel Gears

Screw Gears

Worm Gears

To order J Series products, please specify: **Catalog No. + J + BORE.**

Bore H7	* The product shapes of J Series items are identified by background color.										
Keyway JS9	20	22	25	28	30	32	35	40	45	50	
Screw size	6×2.8			8×3.3			10×3.3		12×3.3		14×3.8
Catalog Number	M5			M6			M8			M10	
AG3-20R1 J BORE											
AG3-20R2 J BORE											
AG3-30R1 J BORE											
AG3-30R2 J BORE											
AG3-40R1 J BORE											
AG3-50R1 J BORE											
AG3-60R1 J BORE											

[Caution on J series] ① Cancellation is not possible for made-to-order products. See page 42 for lead times and allowable order quantities. See page 44 for other precautions.

Gearboxes

Other Products



Specifications	
Precision grade	KHK W 001 grade 2
Reference section of gear	Axial direction
Gear teeth	Standard full depth
Normal pressure angle	20°
Material	S45C
Heat treatment	Gear teeth induction hardened *
Tooth hardness	50 to 60HRC
Surface treatment	Black oxide coated except for ground part

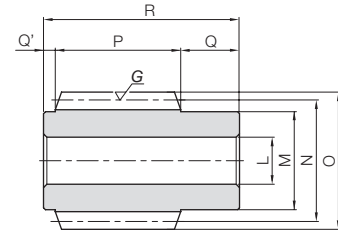

W3

\* Due to the gear teeth being induction hardened, no secondary operations can be performed on tooth areas including the bottom land (approx. 2 to 3 mm).

Catalog Number	Axial module	Number of Starts	Nominal lead angle	Direction of helix	Shape	Bore	Hub dia.	Pitch dia.	Outside dia.	Face width	Hub width (right)	Hub width (left)
						L <sub>H7</sub>	M	N	O	P	Q	Q'
<b>SWG5-R1</b> <b>SWG5-R2</b>	<b>m5</b>	1 2	4°05' 8°08'	R	W3	25	56	70	80	85	30	5
<b>SWG6-R1</b>	<b>m6</b>	1	4°17'	R	W3	30	63	80	92	100	35	5
<b>SWG6-R2 (Made to Order)</b>	<b>m6</b>	2	8°32'	R	W3	30	63	80	92	100	35	5

[Precautions for Made to Order Products] Prices and lead times for Made to Order products require separate estimates. Contact your dealer.

Spur Gears

Helical Gears

Internal Gears

Racks

CP Racks & Pinions

Miter Gears

Bevel Gears

Screw Gears

Worm Gears

Gearboxes

Other Products



Specifications	
Precision grade	KHK W 002 grade 2
Reference section of gear	Rotating plane
Gear teeth	Standard full depth
Normal pressure angle	20°
Material	CAC702 (old JIS A ̢ BC2) *
Heat treatment	—
Tooth hardness	—

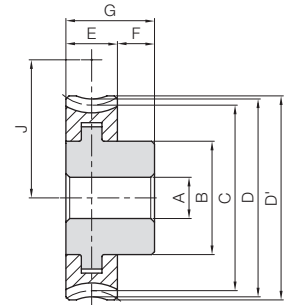

\* The hub material of H4 and H5 is FC200.

Catalog Number	Reduction ratio	Transverse module	No. of teeth	No. of starts of mating worm	Lead angle	Direction of helix	Shape	Bore	Hub dia.	Pitch dia.	Throat dia.	Outside dia.	Face width
								A <sub>H7</sub>	B	C	D	D'	E
<b>AG5-20R1</b>	20	<b>m5</b>	20	1	4°05'	R	H4	22	75	100	110	115	35
<b>AG5-20R2</b>	10		75	100	110				115				
<b>AG5-30R1</b>	30		75	150	160				165				
<b>AG5-30R2</b>	15		75	150	160				165				
<b>AG5-40R1</b>	40		110	200	210				215				
<b>AG5-50R1</b>	50		50	1	4°05'				H5	120	250	260	
<b>AG5-60R1</b>	60	60	1	4°05'	H5	130	300	310					315
<b>AG6-20R1</b>	20	<b>m6</b>	20	1	4°17'	R	H4	25	85	120	132	138	40
<b>AG6-20R2 (Made to Order)</b>	10	<b>m6</b>	20	2	8°32'	R	H4	25	85	120	132	138	40
<b>AG6-30R1</b>	30	<b>m6</b>	30	1	4°17'	R	H5	25	100	180	192	198	40
<b>AG6-30R2 (Made to Order)</b>	15	<b>m6</b>	30	2	8°32'	R	H5	25	100	180	192	198	40
<b>AG6-40R1</b>	40	<b>m6</b>	40	1	4°17'	R	H5	25	120	240	252	258	40
<b>AG6-50R1</b>	50	<b>m6</b>	50	1	4°17'	R	H5	25	130	300	312	318	40
<b>AG6-60R1</b>	60		60	1	4°17'								

[Precautions for Made to Order Products] ① Prices and lead times for Made to Order products require separate estimates. Contact your dealer.



Total length R	Socket head screw		Weight (kg)	Catalog Number
	Size	S		
120	—	—	2.78	<b>SWG5-R1</b> <b>SWG5-R2</b>
140	—	—	4.15	<b>SWG6-R1</b>
140	—	—	4.15	<b>SWG6-R2 (Made to Order)</b>

Worm Wheels

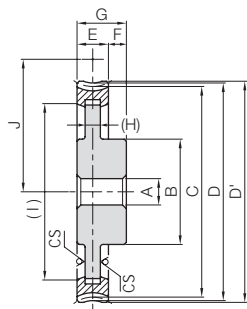

H5



Hub width F	Total length G	Web thickness (H)	Web O.D. (I)	Mounting distance J	Allowable torque (N·m) <small>NOTE 1</small>								Backlash (mm)	Weight (kg)	Catalog Number
					30 rpm	100 rpm	300 rpm	600 rpm	900 rpm	1200 rpm	1800 rpm				
25	60	—	—	85	202	163	127	101	88.4	79.0	65.5	0.07~0.19	2.79	<b>AG5-20R1</b>	
		—	—	85	200	157	117	93.2	80.2	71.1	58.1		2.79	<b>AG5-20R2</b>	
		(21)	(120)	110	427	348	275	224	196	175	147		4.75	<b>AG5-30R1</b>	
		(21)	(120)	110	425	340	259	206	180	159	132		4.75	<b>AG5-30R2</b>	
		(23)	(168)	135	731	597	478	394	346	309	259		8.84	<b>AG5-40R1</b>	
		(23)	(215)	160	1110	903	729	605	534	479	402		12.7	<b>AG5-50R1</b>	
		(24)	(260)	185	1550	1270	1030	855	763	682	575	17.6	<b>AG5-60R1</b>		
30	70	—	—	100	315	252	196	157	135	121	99.6	0.07~0.19	4.53	<b>AG6-20R1</b>	
30	70	—	—	100	314	244	182	145	124	110	89.3	0.07~0.19	4.53	<b>AG6-20R2 (Made to Order)</b>	
30	70	(26)	(142)	130	666	538	424	346	300	267	224	0.07~0.19	8.52	<b>AG6-30R1</b>	
30	70	(26)	(142)	130	668	532	403	321	278	246	203	0.07~0.19	8.52	<b>AG6-30R2 (Made to Order)</b>	
30	70	(30)	(200)	160	1140	923	738	609	528	472	394	0.07~0.19	14.2	<b>AG6-40R1</b>	
30	70	(30)	(258)	190	1720	1400	1130	935	816	733	611	0.07~0.19	21.0	<b>AG6-50R1</b>	
		(30)	(312)	220	2410	1960	1580	1320	1170	1040	875		29.7	<b>AG6-60R1</b>	

[NOTE 1] Allowable torque based on worm speed (rpm).



# Worms



Specifications	
Precision grade	KHK W 001 grade 4
Reference section of gear	Normal plane
Gear teeth	Standard full depth
Normal pressure angle	20°
Material	S45C
Heat treatment	—
Tooth hardness	(less than 194HB)
Surface treatment	Black oxide coating

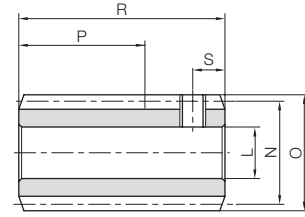

W2

Catalog Number	Normal module	Number of Starts	Nominal lead angle	Direction of helix	Shape	Bore	Hub dia.	Pitch dia.	Outside dia.	Face width	Hub width (right)	Hub width (left)
						L <sub>H8</sub>	M	N	O	P	Q	Q'
<b>SW0.5-R1</b> <b>SW0.5-R2</b>	<b>m0.5</b>	1 2	2°36' 5°13'	R	W2	5	—	11	12	(10)	—	—
<b>SW0.8-R1</b> <b>SW0.8-R2</b>	<b>m0.8</b>	1 2	3°17' 6°34'	R	W2	6	—	14	15.6	(18)	—	—



# Worm Wheels



Specifications	
Precision grade	KHK W 002 grade 4
Reference section of gear	Normal plane
Gear teeth	Standard full depth
Normal pressure angle	20°
Material	CAC502 (old JIS PBC2)
Heat Treatment	—
Tooth hardness	—

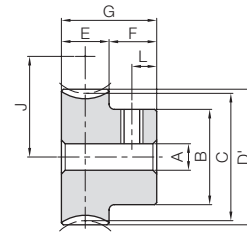

HAT

Catalog Number	Reduction ratio	Normal module	No. of teeth	No. of starts of mating worm	Lead angle	Direction of helix	Shape	Bore	Hub dia.	Pitch dia.	Throat dia.	Outside dia.	Face width
								A <sub>H7</sub>	B	C	D	D'	E
<b>BG0.5-20R1</b>	20	<b>m0.5</b>	20	1	2°36'	R	HAT	4	9	10.01	—	11	5
<b>BG0.5-20R2</b>	10		20	2	5°13'			4	9	10.04		11	
<b>BG0.5-30R1</b>	30		30	1	2°36'			4	12	15.02		16	
<b>BG0.5-30R2</b>	15		30	2	5°13'			4	12	15.06		16	
<b>BG0.5-40R1</b>	40		40	1	2°36'			5	15	20.02		21	
<b>BG0.5-50R1</b>	50		50	1	2°36'			5	20	25.03		26	
<b>BG0.5-60R1</b>	60	60	1	2°36'	5	25	30.03	31					

Catalog Number	Reduction ratio	Normal module	No. of teeth	No. of starts of mating worm	Lead angle	Direction of helix	Shape	Bore	Hub dia.	Pitch dia.	Throat dia.	Outside dia.	Face width
								A <sub>H7</sub>	B	C	D	D'	E
<b>BG0.8-20R1</b>	20	<b>m0.8</b>	20	1	3°17'	R	HA	5	12	16.03	—	17.6	9
<b>BG0.8-20R2</b>	10		20	2	6°34'			5	12	16.11		17.6	
<b>BG0.8-30R1</b>	30		30	1	3°17'			5	18	24.04		25.6	
<b>BG0.8-30R2</b>	15		30	2	6°34'			5	18	24.16		25.6	
<b>BG0.8-40R1</b>	40		40	1	3°17'			6	20	32.05		33.6	
<b>BG0.8-50R1</b>	50		50	1	3°17'			8	25	40.06		41.6	
<b>BG0.8-60R1</b>	60	60	1	3°17'	8	25	48.08	49.6					

[Caution on Product Characteristics] ① The worm wheel is shifted to fit the mounting distance.



Total length R	Socket head screw		Weight (kg)	Catalog Number
	Size	S		
18	M3	3	0.010	<b>SW0.5-R1</b> <b>SW0.5-R2</b>
30	M4	5	0.029	<b>SW0.8-R1</b> <b>SW0.8-R2</b>

**Bronze Worm Wheels**

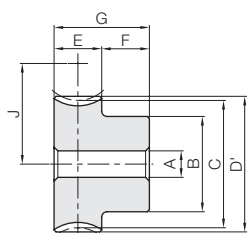

HA



Hub width F	Total length G	Mounting distance J	Socket head screw		Allowable torque (N·m) <small>NOTE 1</small>						Backlash (mm)	Weight (kg)	Catalog Number
			Size	L	30 <sub>rpm</sub>	100 <sub>rpm</sub>	300 <sub>rpm</sub>	600 <sub>rpm</sub>	900 <sub>rpm</sub>	1200 <sub>rpm</sub>			
7	12	10.5	M3	3.5	0.27	0.23	0.19	0.15	0.14	0.13	0~0.16	0.0061	<b>BG0.5-20R1</b>
		10.5	M3		0.28	0.23	0.18	0.15	0.13	0.12		0.0061	<b>BG0.5-20R2</b>
		13	M3		0.58	0.50	0.41	0.34	0.30	0.28		0.014	<b>BG0.5-30R1</b>
		13	M3		0.59	0.49	0.39	0.32	0.29	0.26		0.014	<b>BG0.5-30R2</b>
		15.5	M4		0.99	0.85	0.71	0.60	0.54	0.50		0.023	<b>BG0.5-40R1</b>
		18	M4		1.50	1.28	1.08	0.92	0.83	0.77		0.039	<b>BG0.5-50R1</b>
		20.5	M4		2.10	1.80	1.52	1.31	1.19	1.09		0.059	<b>BG0.5-60R1</b>

Hub width F	Total length G	Mounting distance J	Allowable torque (N·m) <small>NOTE 1</small>						Backlash (mm)	Weight (kg)	Catalog Number
			30 <sub>rpm</sub>	100 <sub>rpm</sub>	300 <sub>rpm</sub>	600 <sub>rpm</sub>	900 <sub>rpm</sub>	1200 <sub>rpm</sub>			
9	18	15	1.05	0.88	0.71	0.58	0.52	0.48	0.04~0.22	0.023	<b>BG0.8-20R1</b>
		15	1.06	0.86	0.66	0.54	0.48	0.44		0.023	<b>BG0.8-20R2</b>
		19	2.23	1.89	1.53	1.29	1.15	1.06		0.055	<b>BG0.8-30R1</b>
		19	2.24	1.87	1.46	1.20	1.07	0.98		0.055	<b>BG0.8-30R2</b>
		23	3.81	3.24	2.67	2.26	2.02	1.87		0.087	<b>BG0.8-40R1</b>
		27	5.76	4.90	4.07	3.47	3.13	2.90		0.13	<b>BG0.8-50R1</b>
		31	8.06	6.88	5.73	4.90	4.46	4.12		0.18	<b>BG0.8-60R1</b>

[NOTE 1] Allowable torque based on worm speed (rpm).



# Worms



Specifications	
Precision grade	KHK W 001 grade 4
Reference section of gear	Normal plane
Gear teeth	Standard full depth
Normal pressure angle	20°
Material	S45C
Heat treatment	—
Tooth hardness	(less than 194HB)
Surface treatment	Black oxide coating

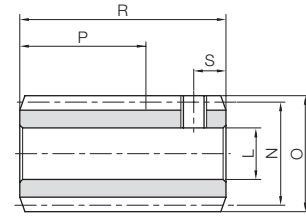

W2

Catalog Number	Normal module	Number of Starts	Nominal lead angle	Direction of helix	Shape	Bore	Hub dia.	Pitch dia.	Outside dia.	Face width	Hub width (right)	Hub width (left)
						L <sub>H7(H8)</sub>	M	N	O	P	Q	Q'
<b>SW1-R1</b> <b>SW1-R2</b>	<b>m1</b>	1 2	3°35' 7°11'	R	W2	6 <sup>H8</sup>	—	16	18	(20)	—	—
<b>SW1.25-R1</b> <b>SW1.25-R2</b>	<b>m1.25</b>	1 2	3°25' 6°50'	R	W2	8	—	21	23.5	(25)	—	—

Spur Gears

Helical Gears

Internal Gears

Racks

CP Racks & Pinions

Miter Gears

Bevel Gears

Screw Gears

Worm Gears

Gearboxes

Other Products



# Worm Wheels

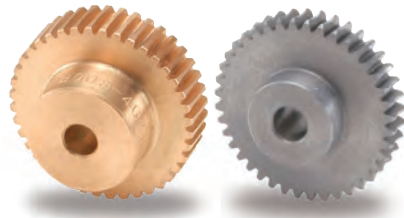

Specifications		
Catalog Number	BG	CG
Precision grade	KHK W 002 grade 4*	
Reference section of gear	Normal plane	
Gear teeth	Standard full depth	
Normal pressure angle	20°	
Material	CAC502 (old JIS PBC2)	FC200
Heat treatment	—	
Tooth hardness	—	

\* The precision grade of J Series products is equivalent to the value shown in the table.

A <sub>H7</sub>	Bore
B	Hub dia.
C	Pitch dia.
D	Throat dia.
D'	Outside dia.
E	Face width
F	Hub width
G	Total length
J	Mounting distance

J

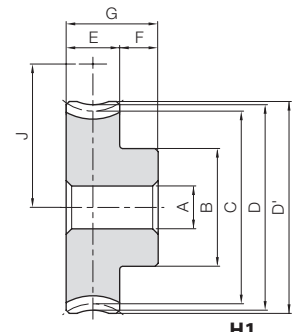

H1

Catalog Number	Reduction ratio	No. of teeth	No. of starts of mating worm	Lead angle helix direction	Shape	A <sub>H7</sub>	B	C	D	D'	E	F	G	J	Allowable torque (N·m) <small>NOTE 1</small>						Backlash (mm)	Weight (kg)		
															30 rpm	100 rpm	300 rpm	600 rpm	900 rpm	1200 rpm				
<b>BG1-20R1</b>	20	20	1	3°35'	R H1	6	16	20.05	22	23	10	10	20	18	1.89	1.58	1.26	1.04	0.92	0.85	0.06~0.24	0.043		
<b>BG1-20R2</b>	10	20	2	7°11'		6	16	20.16	22	23				18	1.90	1.54	1.18	0.97	0.85	0.78		0.043		
<b>BG1-30R1</b>	30	30	1	3°35'		6	20	30.07	32	33				23	4.00	3.38	2.74	2.29	2.05	1.87		0.089		
<b>BG1-30R2</b>	15	30	2	7°11'		6	20	30.24	32	33				23	4.03	3.35	2.62	2.14	1.91	1.74		0.089		
<b>BG1-40R1</b>	40	40	1	3°35'		8	26	40.08	42	43				28	6.85	5.79	4.76	4.03	3.61	3.31		0.15		
<b>BG1-50R1</b>	50	50	1	3°35'	8	30	50.10	52	53	33	10.3	8.76	7.27	6.18	5.58	5.14	0.23							
<b>BG1.25-20R1</b>	20	20	1	3°25'	R H1	6	20	25.04	27.5	28.75	11	9	20	23	3.19	2.65	2.10	1.72	1.53	1.40	0.08~0.26	0.070		
<b>BG1.25-20R2</b>	10	20	2	6°50'		6	20	25.18	27.5	28.75				23	3.19	2.58	1.96	1.60	1.40	1.27		0.070		
<b>BG1.25-50R1</b>	50	50	1	3°25'		8	40	62.61	65	66.25				41.75	17.4	14.7	12.1	10.3	9.25	8.49		0.40		
<b>CG1-60R1</b>	60	60	1	3°35'	R H1	10	30	60.12	62	63	10	10	20	38	8.69	7.39	6.14	5.24	4.78	4.39	0.06~0.24	0.25		
<b>CG1-80R1</b>	80	80					35	80.16	82	83				48	14.7	12.6	10.5	9.11	8.30	7.72		7.22	6.66	0.43
<b>CG1-100R1</b>	100	100					40	100.20	102	103				58	21.9	19.0	16.0	13.9	12.7	11.9		11.9	11.9	0.66
<b>CG1-120R1</b>	120	120					40	120.24	122	123				68	30.5	26.7	22.5	19.6	18.0	16.7		16.7	16.7	0.91

[Caution on Product Characteristics] ① The worm wheel is shifted to fit the mounting distance.

[NOTE 1] Allowable torque based on worm speed (rpm).



Total length	Socket head screw		Weight (kg)	Catalog Number
	R	Size		
32	M4	5	0.043	<b>SW1-R1</b> <b>SW1-R2</b>
37	M5	5	0.085	<b>SW1.25-R1</b> <b>SW1.25-R2</b>

**Bronze Worm Wheels & Gray Iron Worm Wheels**

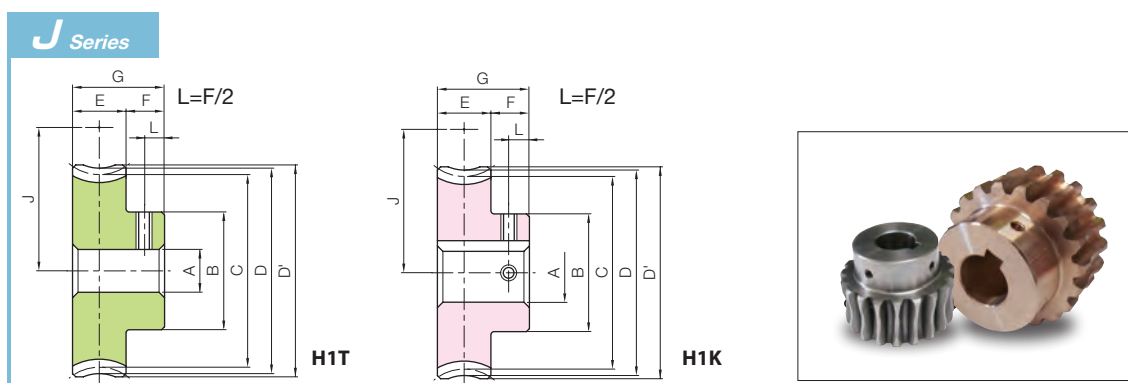

To order J Series products, please specify: **Catalog No. + J + BORE.**

Bore H7	* The product shapes of J Series items are identified by background color.											
Keyway Js9	6	8	10	12	14	15	16	17	18	19	20	22
Screw size	—			4x1.8			5x2.3			6x2.8		
Catalog Number	M4	M5	M4						M5			
BG1-20R1 J BORE												
BG1-20R2 J BORE												
BG1-30R1 J BORE												
BG1-30R2 J BORE												
BG1-40R1 J BORE												
BG1-50R1 J BORE												
BG1.25-20R1 J BORE												
BG1.25-20R2 J BORE												
BG1.25-50R1 J BORE												
CG1-60R1 J BORE												
CG1-80R1 J BORE												
CG1-100R1 J BORE												
CG1-120R1 J BORE												

[Caution on J series] ① Cancellation is not possible for made-to-order products. See page 42 for lead times and allowable order quantities. See page 44 for other precautions.



Specifications	
Precision grade	KHK W 001 grade 4*
Reference section of gear	Normal plane
Gear teeth	Standard full depth
Normal pressure angle	20°
Material	S45C
Heat treatment	—
Tooth hardness	(less than 194HB)
Surface treatment	Black oxide coating

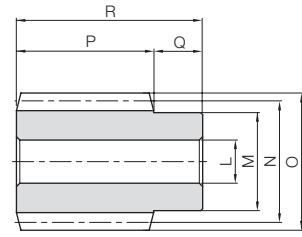

W1

\* The precision grade of J Series products is equivalent to the value shown in the table.

Catalog Number ● : J Series (Available-on-request)	Normal module	Number of Starts	Nominal lead angle	Direction of helix	Shape	Bore	Hub dia.	Pitch dia.	Outside dia.	Face width	Hub width (right)	Hub width (left)
						L <sub>H7</sub>	M	N	O	P	Q	Q'
<b>SW1.5-R1</b> ● <b>SW1.5-R1J8</b> ● <b>SW1.5-R1J10</b>	m1.5	1	3°26'	R	W1 W1T W1K	8 8 10	20	25	28	30	10	—
<b>SW1.5-R2</b> ● <b>SW1.5-R2J8</b> ● <b>SW1.5-R2J10</b>		2	6°54'		W1 W1T W1K	8 8 10						

[Caution on J series] ① Cancellation is not possible for made-to-order products. See page 42 for lead times and allowable order quantities. See page 44 for other precautions.

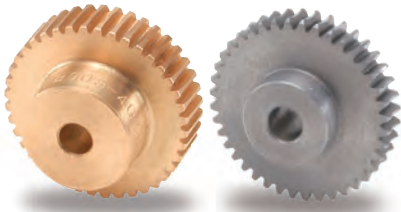

Specifications		
Catalog Number	BG	CG
Precision grade	KHK W 002 grade 4*	
Reference section of gear	Normal plane	
Gear teeth	Standard full depth	
Normal pressure angle	20°	
Material	CAC502 (old JIS PBC2)	FC200
Heat treatment	—	
Tooth hardness	—	

\* The precision grade of J Series products is equivalent to the value shown in the table.

A <sub>H7</sub>	Bore
B	Hub dia.
C	Pitch dia.
D	Throat dia.
D'	Outside dia.
E	Face width
F	Hub width
G	Total length
J	Mounting distance

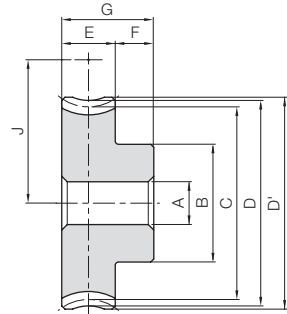

H1

Catalog Number	Reduction ratio	No. of teeth	No. of starts of mating worm	Lead angle helix direction	Shape	A <sub>H7</sub>	B	C	D	D'	E	F	G	J	Allowable torque (N·m) <small>NOTE 1</small>						Backlash (mm)	Weight (kg)		
															30 <sub>rpm</sub>	100 <sub>rpm</sub>	300 <sub>rpm</sub>	600 <sub>rpm</sub>	900 <sub>rpm</sub>	1200 <sub>rpm</sub>				
<b>BG1.5-20R1</b>	20	20	1	3°26'	R	H1	8	22	30.05	33	34.5	12	10	22	27.5	4.76	3.96	3.10	2.56	2.27	0.08~0.26	0.10		
<b>BG1.5-20R2</b>	10	20	2	6°54'			8	22	30.22	33	34.5	12		22	27.5	4.75	3.85	2.89	2.38	2.08		1.87	0.10	
<b>BG1.5-30R1</b>	30	30	1	3°26'	R	H1	10	30	45.08	48	49.5	12	10	22	35	10.1	8.47	6.72	5.67	5.03	0.08~0.26	0.22		
<b>BG1.5-30R2</b>	15	30	2	6°54'			10	30	45.33	48	49.5	12		22	35	10.1	8.37	6.40	5.26	4.67		4.20	0.22	
<b>BG1.5-40R1</b>	40	40	1	3°26'	R	H1	12	30	60.11	63	64.5	12	10	22	42.5	17.2	14.5	11.7	9.96	8.86	0.08~0.26	0.35		
<b>BG1.5-50R1</b>	50	50	1	3°26'			12	40	75.13	78	79.5	14		24	50	30.4	25.6	20.8	17.8	16.0		14.6	0.65	
<b>CG1.5-30R1</b>	30	30	1	3°26'	R	H1	10	30	45.08	48	49.5	12	10	22	35	6.04	5.08	4.03	3.40	3.02	0.08~0.26	0.18		
<b>CG1.5-40R1</b>	40	40					12	30	60.11	63	64.5	12		22	42.5	10.3	8.71	7.01	5.98	5.31		4.83	0.28	
<b>CG1.5-50R1</b>	50	50					12	40	75.13	78	79.5	14		24	50	18.2	15.4	12.5	10.7	9.59		8.74	8.04	0.53
<b>CG1.5-60R1</b>	60	60					12	40	90.16	93	94.5	14		24	57.5	25.5	21.6	17.6	15.1	13.7		12.4	12.4	0.73

[Caution on Product Characteristics] ① The worm wheel is shifted to fit the mounting distance.

[NOTE 1] Allowable torque based on worm speed (rpm).



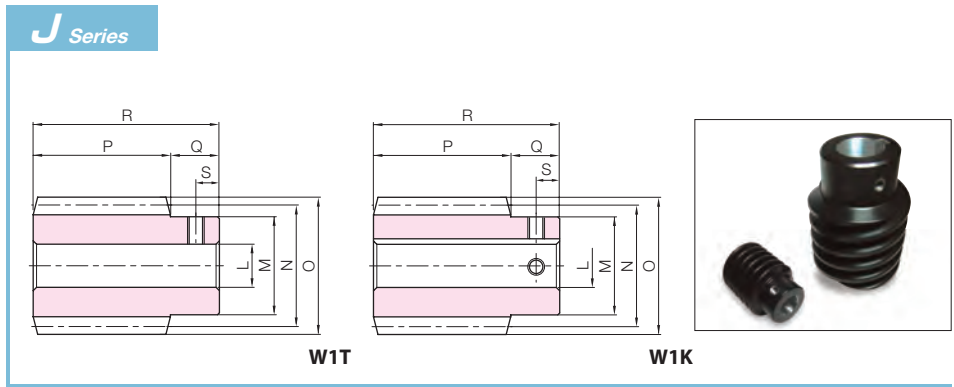

Total length R	Keyway Width x Depth	Socket head screw		Weight (kg)	Catalog Number ● : J Series (Available-on-request)
		Size	S		
40	—	—	—	0.12	SW1.5-R1
	—	M5	5	0.12	● SW1.5-R1J8
	4 x 1.8	M4	5	0.11	● SW1.5-R1J10
	—	—	—	0.12	SW1.5-R2
	—	M5	5	0.12	● SW1.5-R2J8
	4 x 1.8	M4	5	0.11	● SW1.5-R2J10

Bronze Worm Wheels & Gray Iron Worm Wheels

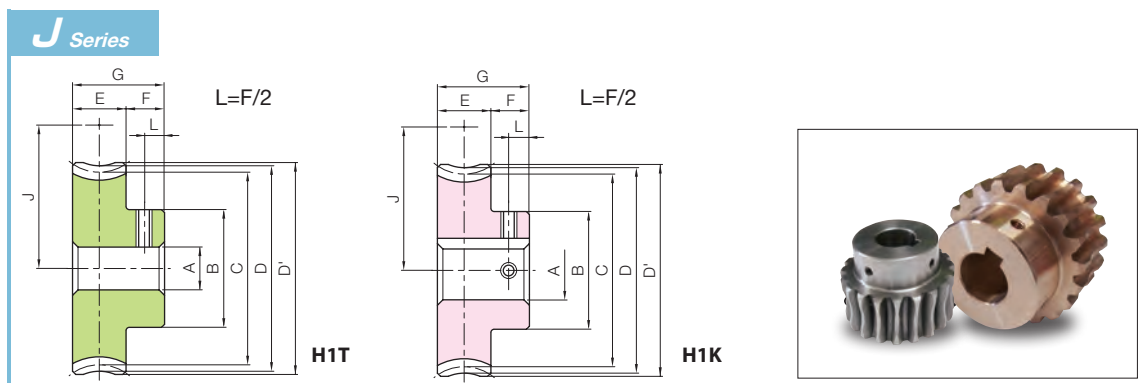

To order J Series products, please specify: **Catalog No. + J + BORE.**

Bore H7	* The product shapes of J Series items are identified by background color.														
Keyway JS9	8	10	12	14	15	16	17	18	19	20	22	25	28	30	
Screw size	—	4x1.8			5x2.3			6x2.8			8x3.3				
Catalog Number	M5	M4					M5					M6			
BG1.5-20R1 J BORE															
BG1.5-20R2 J BORE															
BG1.5-30R1 J BORE															
BG1.5-30R2 J BORE															
BG1.5-40R1 J BORE															
BG1.5-50R1 J BORE															
CG1.5-30R1 J BORE															
CG1.5-40R1 J BORE															
CG1.5-50R1 J BORE															
CG1.5-60R1 J BORE															

[Caution on J series] ① Cancellation is not possible for made-to-order products. See page 42 for lead times and allowable order quantities. See page 44 for other precautions.

- Spur Gears
- Helical Gears
- Internal Gears
- Racks
- CP Racks & Pinions
- Miter Gears
- Bevel Gears
- Screw Gears
- Worm Gears
- Gearboxes
- Other Products



Specifications	
Precision grade	KHK W 001 grade 4*
Reference section of gear	Normal plane
Gear teeth	Standard full depth
Normal pressure angle	14°30'
Material	S45C
Heat treatment	—
Tooth hardness	(less than 194HB)
Surface treatment	Black oxide coating

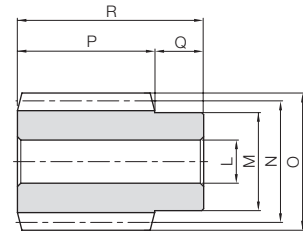

W1

\* The precision grade of J Series products is equivalent to the value shown in the table.

Catalog Number ● : J Series (Available-on-request)	Normal module	Number of Starts	Nominal lead angle	Direction of helix	Shape	Bore	Hub dia.	Pitch dia.	Outside dia.	Face width	Hub width (right)	Hub width (left)
						LH7	M	N	O	P	Q	Q'
SW2-R1 ● SW2-R1J12 ● SW2-R1J14	m2	1	3°42'	R	W1	12	25	31	35	32	14	—
W1K					12							
W1K					14							
W1K					14							
SW2-R2 ● SW2-R2J12 ● SW2-R2J14		2	7°25'	L	W1	12						
W1K					12							
W1K					12							
W1K					14							
SW2-L1 ● SW2-L1J12 ● SW2-L1J14	1	3°42'	R	W1	12							
W1K				12								
W1K				12								
W1K				14								
SW2-L2 ● SW2-L2J12 ● SW2-L2J14	2	7°25'	L	W1	12							
W1K				12								
W1K				12								
W1K				14								

[Caution on J series] ① Cancellation is not possible for made-to-order products. See page 42 for lead times and allowable order quantities. See page 44 for other precautions.

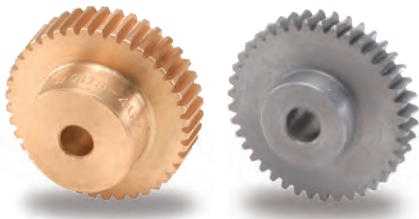

Specifications	
Catalog Number	BG CG
Precision grade	KHK W 002 grade 4*
Reference section of gear	Normal plane
Gear teeth	Standard full depth
Normal pressure angle	14°30'
Material	CAC502 (old JIS PBC2) FC200
Heat treatment	—
Tooth hardness	—

AH7	Bore
B	Hub dia.
C	Pitch dia.
D	Throat dia.
D'	Outside dia.
E	Face width
F	Hub width
G	Total length
J	Mounting distance

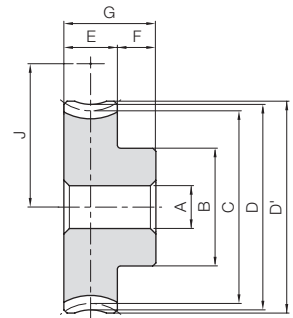

H1

\* The precision grade of J Series products is equivalent to the value shown in the table.

Catalog Number	Reduction ratio	No. of teeth	No. of starts of mating worm	Lead angle helix direction	Shape	AH7	B	C	D	D'	E	F	G	J	Allowable torque (N·m) <small>NOTE 1</small>						Backlash (mm)	Weight (kg)
															30 rpm	100 rpm	300 rpm	600 rpm	900 rpm	1200 rpm		
BG2-20R1 BG2-20R2	20 10	20	1	3°42'	R	12	33	40.08 40.34	44	46	22	13	35	35.5	12.3	10.2	8.00	6.59	5.78	5.25	0.10~0.28	0.33
BG2-20L1 BG2-20L2	20 10			7°25'	L										12.3	10.2	8.00	6.59	5.78	5.25		
CG2-20R1 CG2-20R2 CG2-30R1 CG2-30R2 CG2-40R1	20 10 30 15 40	20 20 30 30 40	1 2 1 2 1	3°42' 7°25' 3°42' 7°25' 3°42'	R	12	33	40.08 40.34	44	46	22	13	35	35.5	7.38	6.15	4.80	3.95	3.47	3.15	0.10~0.28	0.27 0.27 0.57 0.57 0.96
CG2-50R1 CG2-50R2 CG2-60R1	50 25 60	50 50 60	1 2 1	3°42' 7°25' 3°42'	H1										48	100.21 100.84 120.25	104 104 124	106 106 126	65.5 65.5 75.5	40.3 40.7 56.4		
CG2-20L1 CG2-20L2 CG2-30L1 CG2-40L1	20 10 30 40	20 20 30 40	1 2 1 1	3°42' 7°25' 3°42' 3°42'	L	12	33	40.08 40.34	44	46	22	13	35	35.5	7.38	6.15	4.80	3.95	3.47	3.15	0.10~0.28	0.27 0.27 0.57 0.96
CG2-50L1 CG2-60L1	50 60	50 60	1 1	3°42' 3°42'	H1										48	100.21 120.25	104 124	106 126	65.5 75.5	40.3 56.4		

[Caution on Product Characteristics] ① The worm wheel is shifted to fit the mounting distance.

[NOTE 1] Allowable torque based on worm speed (rpm).



J Series

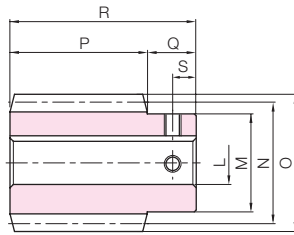

W1K



Total length R	Keyway Width x Depth	Socket head screw		Weight (kg)	Catalog Number ● : J Series (Available-on-request)
		Size	S		
46	—	—	—	0.20	SW2-R1
	4 x 1.8	M4	7	0.20	●SW2-R1J12
	5 x 2.3	M4	7	0.18	●SW2-R1J14
	—	—	—	0.20	SW2-R2
	4 x 1.8	M4	7	0.20	●SW2-R2J12
	5 x 2.3	M4	7	0.18	●SW2-R2J14
	—	—	—	0.20	SW2-L1
	4 x 1.8	M4	7	0.20	●SW2-L1J12
	5 x 2.3	M4	7	0.18	●SW2-L1J14
	—	—	—	0.20	SW2-L2
	4 x 1.8	M4	7	0.20	●SW2-L2J12
	5 x 2.3	M4	7	0.18	●SW2-L2J14



J Series

Bronze Worm Wheels & Gray Iron Worm Wheels

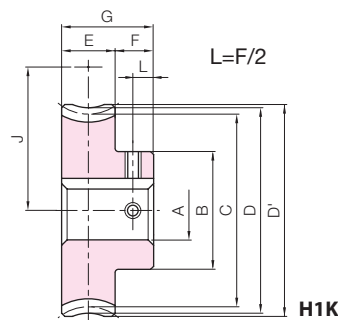

H1K



To order J Series products, please specify: **Catalog No. + J + BORE.**

Bore H7	* The product shapes of J Series items are identified by background color.													
Keyway JS9	12	14	15	16	17	18	19	20	22	25	28	30	32	35
Screw size	4x1.8	5x2.3				6x2.8				8x3.3			10x3.3	
Catalog Number	M4					M5				M6			M8	
BG2-20R1 J BORE														
BG2-20R2 J BORE														
BG2-20L1 J BORE														
BG2-20L2 J BORE														
CG2-20R1 J BORE														
CG2-20R2 J BORE														
CG2-30R1 J BORE														
CG2-30R2 J BORE														
CG2-40R1 J BORE														
CG2-50R1 J BORE														
CG2-50R2 J BORE														
CG2-60R1 J BORE														
CG2-20L1 J BORE														
CG2-20L2 J BORE														
CG2-30L1 J BORE														
CG2-40L1 J BORE														
CG2-50L1 J BORE														
CG2-60L1 J BORE														

[Caution on J series] ① Cancellation is not possible for made-to-order products. See page 42 for lead times and allowable order quantities. See page 44 for other precautions.

Spur Gears

Helical Gears

Internal Gears

Racks

CP Racks & Pinions

Miter Gears

Bevel Gears

Screw Gears

Worm Gears

Gearboxes

Other Products



Specifications	
Precision grade	KHK W 001 grade 4*
Reference section of gear	Normal plane
Gear teeth	Standard full depth
Normal pressure angle	20°
Material	S45C
Heat treatment	—
Tooth hardness	(less than 194HB)
Surface treatment	Black oxide coating

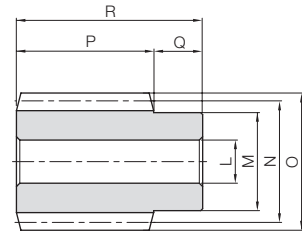

W1

\* The precision grade of J Series products is equivalent to the value shown in the table.

Catalog Number ● : J Series (Available-on-request)	Normal module	Number of Starts	Nominal lead angle	Direction of helix	Shape	Bore	Hub dia.	Pitch dia.	Outside dia.	Face width	Hub width (right)	Hub width (left)
						LH7	M	N	O	P	Q	Q'
SW2.5-R1 ● SW2.5-R1J15 ● SW2.5-R1J16 ● SW2.5-R1J17	m2.5	1	3°52'	R	W1	15	30	37	42	45	18	—
W1K					15							
W1K		16										
W1K		17										
SW2.5-R2 ● SW2.5-R2J15 ● SW2.5-R2J16 ● SW2.5-R2J17		2	7°46'		W1	15						
					W1K	15						
					W1K	16						
					W1K	17						
SW2.5-L1 ● SW2.5-L1J15 ● SW2.5-L1J16 ● SW2.5-L1J17		1	3°52'	L	W1	15						
	W1K				15							
	W1K				16							
	W1K				17							
SW2.5-L2 ● SW2.5-L2J15 ● SW2.5-L2J16 ● SW2.5-L2J17		2	7°46'		W1	15						
					W1K	15						
					W1K	16						
					W1K	17						

[Caution on J series] ① Cancellation is not possible for made-to-order products. See page 42 for lead times and allowable order quantities. See page 44 for other precautions.

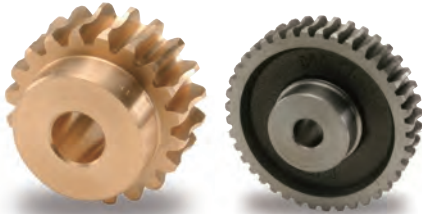

Specifications	
Catalog Number	BG CG
Precision grade	KHK W 002 grade 4*
Reference section of gear	Normal plane
Gear teeth	Standard full depth
Normal pressure angle	20°
Material	CAC502 (old JIS PBC2) FC200
Heat treatment	—
Tooth hardness	—

\* The precision grade of J Series products is equivalent to the value shown in the table.

A <sub>H7</sub>	Bore
B	Hub dia.
C	Pitch dia.
D	Throat dia.
D'	Outside dia.
E	Face width
F	Hub width
G	Total length
(H)	Web thickness
(I)	Web O.D.
J	Mounting distance

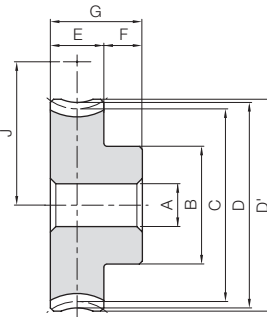

H1

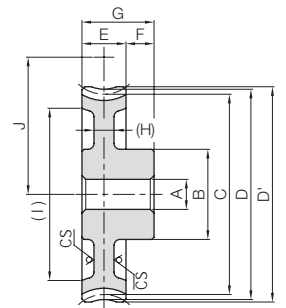

HB

\*\* CS has a forged finish surface.

Catalog Number	Reduction ratio	No. of teeth	No. of starts of mating worm	Lead angle helix direction	Shape	A <sub>H7</sub>	B	C	D	D'	E	F	G	(H)	(I)	J	Allowable torque (N·m) <small>NOTE 1</small>						Backlash (mm)	Weight (kg)	
																	30 rpm	100 rpm	300 rpm	600 rpm	900 rpm	1200 rpm			
BG2.5-20R1 BG2.5-20R2	20 10	20	1 2	3°52' 7°46'	R	12	35	50.11 50.46	55	57.5	22	14	36	—	—	43.5	21.5 21.5	17.7 17.3	13.8 13.0	11.4 10.6	9.94 9.14	9.07 8.27	0.13~0.31	0.49	
BG2.5-20L1 BG2.5-20L2	20 10	20	1 2	3°52' 7°46'	L	12	35	50.11 50.46	55	57.5	22	14	36	—	—	43.5	21.5 21.5	17.7 17.3	13.8 13.0	11.4 10.6	9.94 9.14	9.07 8.27	0.13~0.31	0.49	
CG2.5-20R1 CG2.5-20R2 CG2.5-30R1 CG2.5-40R1	20 10 30 40	20 20 30 40	1 2 1 1	3°52' 7°46' 3°52' 3°52'	R	12 12 12 15	35 35 40 45	50.11 50.46 75.17 100.23	55 55 80 105	57.5 57.5 82.5 107.5	22	14	36	—	—	43.5	43.5 43.5 56 68.5	12.9 12.9 27.3 46.7	10.6 10.4 22.8 39.0	8.30 7.78 18.0 31.3	6.83 6.36 15.1 26.5	5.97 5.49 13.2 23.3	5.44 4.96 12.0 21.2	0.13~0.31	0.40 0.40 0.82 1.39
CG2.5-50R1 CG2.5-60R1	50 60	50 60	1 1	3°52' 3°52'	HB	15	50 55	125.29 150.34	130 155	132.5 157.5	22	14	36	(9)	(110) (136)	81 93.5	70.6 98.8	59.0 82.9	47.8 67.3	40.7 57.6	36.1 51.5	33.0 47.0	0.13~0.31	1.54 2.02	
CG2.5-20L1 CG2.5-20L2 CG2.5-40L1	20 10 40	20 20 40	2 2 1	3°52' 7°46' 3°52'	L	12 12 15	35 35 45	50.11 50.46 100.23	55 55 105	57.5 57.5 107.5	22	14	36	—	—	43.5	43.5 43.5 68.5	12.9 12.9 46.7	10.6 10.4 39.0	8.30 7.78 31.3	6.83 6.36 26.5	5.97 5.49 23.3	5.44 4.96 21.2	0.13~0.31	0.40 0.40 1.39

[Caution on Product Characteristics] ① The worm wheel is shifted to fit the mounting distance.

[NOTE 1] Allowable torque based on worm speed (rpm).



J Series

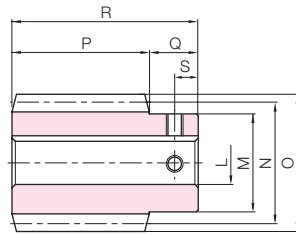

W1K



Total length R	Keyway Width x Depth	Socket head screw		Weight (kg)	Catalog Number ● : J Series (Available-on-request)
		Size	S		
63	—	—	—	0.39	SW2.5-R1
	5 x 2.3	M4	9	0.39	● SW2.5-R1J15
	5 x 2.3	M4	9	0.37	● SW2.5-R1J16
	5 x 2.3	M4	9	0.36	● SW2.5-R1J17
	—	—	—	0.39	SW2.5-R2
	5 x 2.3	M4	9	0.39	● SW2.5-R2J15
	5 x 2.3	M4	9	0.37	● SW2.5-R2J16
	5 x 2.3	M4	9	0.36	● SW2.5-R2J17
	—	—	—	0.39	SW2.5-L1
	5 x 2.3	M4	9	0.39	● SW2.5-L1J15
	5 x 2.3	M4	9	0.37	● SW2.5-L1J16
	5 x 2.3	M4	9	0.36	● SW2.5-L1J17
—	—	—	0.39	SW2.5-L2	
5 x 2.3	M4	9	0.39	● SW2.5-L2J15	
5 x 2.3	M4	9	0.37	● SW2.5-L2J16	
5 x 2.3	M4	9	0.36	● SW2.5-L2J17	



J Series

Bronze Worm Wheels & Gray Iron Worm Wheels

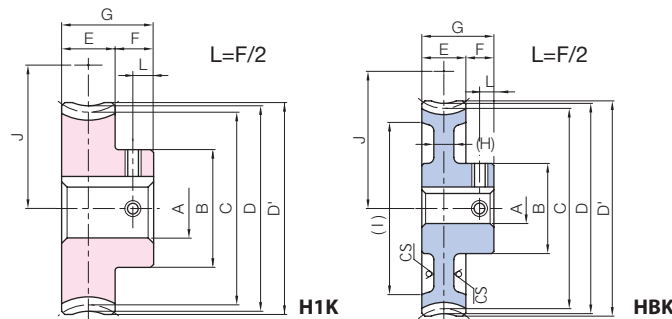

To order J Series products, please specify: **Catalog No. + J + BORE.**

Bore H7	* The product shapes of J Series items are identified by background color.													
Keyway JS9	12	14	15	16	17	18	19	20	22	25	28	30	32	35
Screw size	4x1.8	5x2.3				6x2.8				8x3.3			10x3.3	
Catalog Number	M4				M5				M6			M8		
BG2.5-20R1 J BORE														
BG2.5-20R2 J BORE														
BG2.5-20L1 J BORE														
BG2.5-20L2 J BORE														
CG2.5-20R1 J BORE														
CG2.5-20R2 J BORE														
CG2.5-30R1 J BORE														
CG2.5-40R1 J BORE														
CG2.5-50R1 J BORE														
CG2.5-60R1 J BORE														
CG2.5-20L1 J BORE														
CG2.5-20L2 J BORE														
CG2.5-40L1 J BORE														

[Caution on J series] ① Cancellation is not possible for made-to-order products. See page 42 for lead times and allowable order quantities. See page 44 for other precautions.

Spur Gears

Helical Gears

Internal Gears

Racks

CP Racks & Pinions

Miter Gears

Bevel Gears

Screw Gears

Worm Gears

Gearboxes

Other Products



Specifications	
Precision grade	KHK W 001 grade 4*
Reference section of gear	Normal plane
Gear teeth	Standard full depth
Normal pressure angle	14°30'
Material	S45C
Heat treatment	—
Tooth hardness	(less than 194HB)
Surface treatment	Black oxide coating

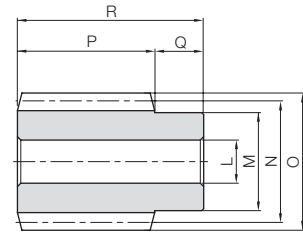

W1

\* The precision grade of J Series products is equivalent to the value shown in the table.

Catalog Number ● : J Series (Available-on-request)	Normal module	Number of Starts	Nominal lead angle	Direction of helix	Shape	Bore	Hub dia.	Pitch dia.	Outside dia.	Face width	Hub width (right)	Hub width (left)
						LH7	M	N	O	P	Q	Q'
SW3-R1 ● SW3-R1J17 ● SW3-R1J18 ● SW3-R1J19 ● SW3-R1J20	m3	1	3°55'	R	W1	16	35	44	50	50	20	—
W1K					17							
W1K		18										
W1K		19										
SW3-R2 ● SW3-R2J17 ● SW3-R2J18 ● SW3-R2J19 ● SW3-R2J20		2	7°50'		W1	16						
					W1K	17						
					W1K	18						
					W1K	19						
					W1K	20						
SW3-L1 ● SW3-L1J17 ● SW3-L1J18 ● SW3-L1J19 ● SW3-L1J20		1	3°55'	L	W1	16						
	W1K				17							
	W1K	18										
	W1K	19										
SW3-L2 ● SW3-L2J17 ● SW3-L2J18 ● SW3-L2J19 ● SW3-L2J20		2	7°50'		W1	16						
	W1K			17								
					W1K	18						
					W1K	19						
					W1K	20						

[Caution on J series] ① Cancellation is not possible for made-to-order products. See page 42 for lead times and allowable order quantities. See page 44 for other precautions.

BG/CG Module 3  
Worm Wheels

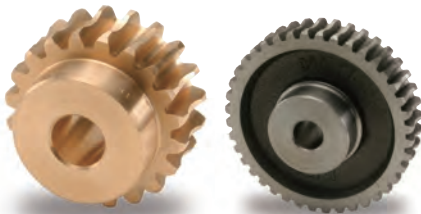

Specifications	
Catalog Number	BG CG
Precision grade	KHK W 002 grade 4*
Reference section of gear	Normal plane
Gear teeth	Standard full depth
Normal pressure angle	14°30'
Material	CAC502 (old JIS PBC2) FC200
Heat treatment	—
Tooth hardness	—

A <sub>H7</sub>	Bore
B	Hub dia.
C	Pitch dia.
D	Throat dia.
D'	Outside dia.
E	Face width
F	Hub width
G	Total length
(H)	Web thickness
(I)	Web O.D.
J	Mounting distance

\* The precision grade of J Series products is equivalent to the value shown in the table.

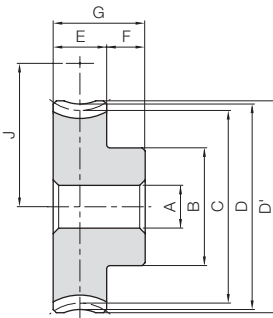

H1

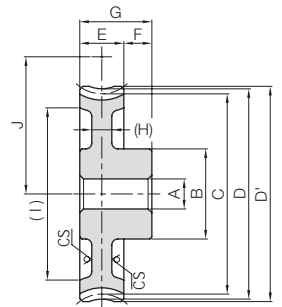

HB

\*\* CS has a forged finish surface.

Catalog Number	Reduction ratio	No. of teeth	No. of starts of mating worm	Lead angle helix direction	Shape	A <sub>H7</sub>	B	C	D	D'	E	F	G	(H)	(I)	J	Allowable torque (N·m) <small>NOTE 1</small>						Backlash (mm)	Weight (kg)
																	30 rpm	100 rpm	300 rpm	600 rpm	900 rpm	1200 rpm		
BG3-20R1 BG3-20R2	20/10	20	1/2	3°55'/7°50'	R	20	50	60.14/60.57	66	69	28	15	43	—	—	52	36.8/37.0	30.1/29.5	23.5/22.1	19.1/17.9	16.7/15.4	15.2/14.0	0.15~0.33	0.89
BG3-20L1 BG3-20L2	20/10	20	1/2	3°55'/7°50'	L	20	50	60.14/60.57	66	69	28	15	43	—	—	52	36.8/37.0	30.1/29.5	23.5/22.1	19.1/17.9	16.7/15.4	15.2/14.0	0.15~0.33	0.89
CG3-20R1 CG3-20R2 CG3-30R1 CG3-30R2	20/10 20/20 30/30 15/30	20 20 30 15	1 2 1 2	3°55'/7°50'	R	20	50	60.14/60.57 55/90.21 55/90.85	66 66 96 96	69 69 99 99	28	15	43	—	—	52 52 67 67	22.1/22.2 18.1/17.7 14.1/13.3 11.5/10.7	18.1/17.7 13.3/10.7 10.7/9.24 10.7/9.24	14.1/13.3 11.5/10.7 10.7/9.24 10.7/9.24	11.5/10.7 10.7/9.24 9.24/8.63 9.24/8.63	10.0/9.24 9.24/8.63 8.63/8.06 8.06/7.49	15.2/14.0 14.0/13.0 13.0/12.0 12.0/11.0	0.15~0.33	0.73 0.73 1.50 1.50
CG3-40R1 CG3-50R1 CG3-60R1	40/20 50/25 60/30	40 50 60	1 1 1	3°55'	HB	20	50	60.14/60.57 55/90.21	66 66 96 96	69 69 99 99	28	15	45	(9)	(107) (138) (166)	82 97 112	79.8/121 66.3/100 53.2/81.1	66.3/100 53.2/81.1 44.6/68.4	53.2/81.1 44.6/68.4 39.1/60.5	44.6/68.4 39.1/60.5 39.1/60.5	39.1/60.5 30.7/46.6 22.2/32.2	—	0.15~0.33	1.93 2.67 3.58
CG3-20L1 CG3-20L2 CG3-30L1	20/10 10/20 30/30	20 10 30	1 2 1	3°55'	L	20	50	60.14/60.57 55/90.21	66 66 96	69 69 99	28	15	43	—	—	52 52 67	22.1/22.2 18.1/17.7 14.1/13.3	18.1/17.7 13.3/10.7 10.7/9.24	14.1/13.3 11.5/10.7 9.24/8.63	11.5/10.7 10.7/9.24 9.24/8.63	10.0/9.24 9.24/8.63 8.63/8.06	—	0.15~0.33	0.73 0.73 1.50
CG3-60L1	60/30	60	1	3°55'	HB	20	70	180.42	186	189	30	45	(9)	(166)	112	169	141	114	96.7	86.3	—	3.58		

[Caution on Product Characteristics] ① The worm wheel is shifted to fit the mounting distance.

[NOTE 1] Allowable torque based on worm speed (rpm).



J Series

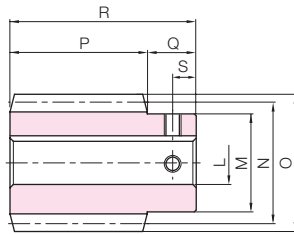

W1K



Total length	Keyway	Socket head screw		Weight (kg)	Catalog Number ● : J Series (Available-on-request)
R	Width x Depth	Size	S		
70	—	—	—	0.64	SW3-R1
	5 x 2.3	M4	10	0.62	● SW3-R1J17
	6 x 2.8	M5	10	0.60	● SW3-R1J18
	6 x 2.8	M5	10	0.58	● SW3-R1J19
	6 x 2.8	M5	10	0.56	● SW3-R1J20
	—	—	—	0.64	SW3-R2
	5 x 2.3	M4	10	0.62	● SW3-R2J17
	6 x 2.8	M5	10	0.60	● SW3-R2J18
	6 x 2.8	M5	10	0.58	● SW3-R2J19
	6 x 2.8	M5	10	0.56	● SW3-R2J20
	—	—	—	0.64	SW3-L1
	5 x 2.3	M4	10	0.62	● SW3-L1J17
6 x 2.8	M5	10	0.60	● SW3-L1J18	
6 x 2.8	M5	10	0.58	● SW3-L1J19	
6 x 2.8	M5	10	0.56	● SW3-L1J20	
—	—	—	0.64	SW3-L2	
5 x 2.3	M4	10	0.62	● SW3-L2J17	
6 x 2.8	M5	10	0.60	● SW3-L2J18	
6 x 2.8	M5	10	0.58	● SW3-L2J19	
6 x 2.8	M5	10	0.56	● SW3-L2J20	



J Series

Bronze Worm Wheels & Gray Iron Worm Wheels

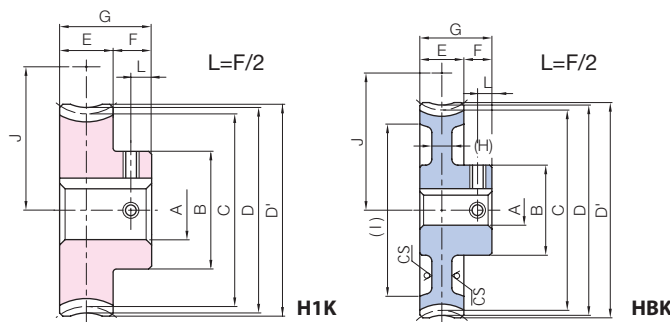

To order J Series products, please specify: **Catalog No. + J + BORE.**

Bore H7	* The product shapes of J Series items are identified by background color.							
Keyway Js9	20	22	25	28	30	32	35	40
Screw size	6x2.8		8x3.3			10x3.3		12x3.3
Catalog Number	M5		M6			M8		
BG3-20R1 J BORE								
BG3-20R2 J BORE								
BG3-20L1 J BORE								
BG3-20L2 J BORE								
CG3-20R1 J BORE								
CG3-20R2 J BORE								
CG3-30R1 J BORE								
CG3-30R2 J BORE								
CG3-40R1 J BORE								
CG3-50R1 J BORE								
CG3-60R1 J BORE								
CG3-20L1 J BORE								
CG3-20L2 J BORE								
CG3-30L1 J BORE								
CG3-60L1 J BORE								

[Caution on J series] ① Cancellation is not possible for made-to-order products. See page 42 for lead times and allowable order quantities. See page 44 for other precautions.

Spur Gears

Helical Gears

Internal Gears

Racks

CP Racks & Pinions

Miter Gears

Bevel Gears

Screw Gears

Worm Gears

Gearboxes

Other Products

**S**

Specifications	
Precision grade	KHK W 001 grade 4
Reference section of gear	Normal plane
Gear teeth	Standard full depth
Normal pressure angle	14°30'
Material	S45C
Heat treatment	—
Tooth hardness	(less than 194HB)
Surface treatment	Black oxide coating (excludes semi-custom products)

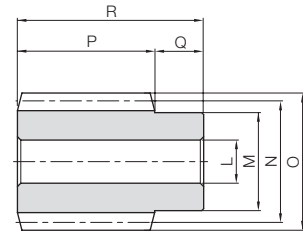
**W1**

Catalog Number	Normal module	Number of Starts	Nominal lead angle	Direction of helix	Shape	Bore	Hub dia.	Pitch dia.	Outside dia.	Face width	Hub width (right)	Hub width (left)
						L <sub>H7</sub>	M	N	O	P	Q	Q'
<b>SW4-R1</b> <b>SW4-R2</b>	<b>m4</b>	1 2	3°42' 7°25'	R	W1	22	50	62	70	70	25	—
<b>SW4-L1S</b> <b>SW4-L2S</b>	<b>m4</b>	1 2	3°42' 7°25'	L	W1	22	50	62	70	70	25	—

[Caution on Product Characteristics] ① Products with S at the end of the catalog number are semi-custom stock products. See page 42 for lead times and allowable order quantities. See page 44 for other precautions.

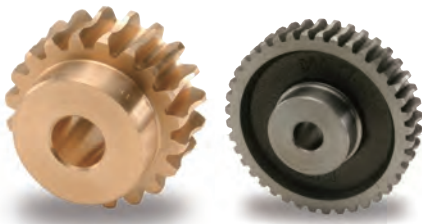
**M S**

Specifications		
Catalog Number	BG	CG
Precision grade	KHK W 002 grade 4	KHK W 002 grade 4
Reference section of gear	Normal plane	Normal plane
Gear teeth	Standard full depth	Standard full depth
Normal pressure angle	14°30'	14°30'
Material	CAC502 (old JIS PBC2)	FC200
Heat Treatment	—	—
Tooth hardness	—	—

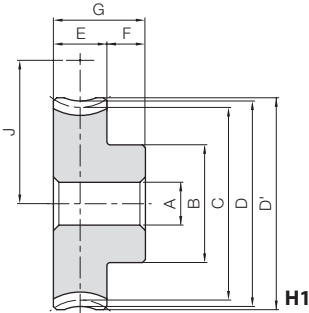

Catalog Number	Reduction ratio	Normal module	No. of teeth	No. of starts of mating worm	Lead angle	Direction of helix	Shape	Bore	Hub dia.	Pitch dia.	Throat dia.	Outside dia.	Face width
								A <sub>H7</sub>	B	C	D	D'	E
<b>BG4-20R1</b> <b>BG4-20R2</b>	20 10	<b>m4</b>	20	1 2	3°42' 7°25'	R	H1	20	60	80.17 80.67	88	90	35

Catalog Number	Reduction ratio	Normal module	No. of teeth	No. of starts of mating worm	Lead angle	Direction of helix	Shape	Bore	Hub dia.	Pitch dia.	Throat dia.	Outside dia.	Face width
								A <sub>H7</sub>	B	C	D	D'	E
<b>CG4-20R1</b>	20	<b>m4</b>	20	1	3°42'	R	H1	20	60	80.17	88	90	35
<b>CG4-20R2</b>	10		20	2	7°25'								
<b>CG4-30R1</b>	30		30	1	3°42'								
<b>CG4-30R2 (Made to Order)</b>	15	<b>m4</b>	30	2	7°25'	R	H1	20	60	121.01	128	130	35
<b>CG4-40R1</b>	40	<b>m4</b>	40	1	3°42'	R	HB	20	70	160.33	168	171	35
<b>CG4-50R1</b> <b>CG4-60R1</b>	50 60	<b>m4</b>	50 60	1	3°42'	R	H2	20	70 80	200.42 240.5	208 248	211 251	35
<b>CG4-20L1S</b>	20	<b>m4</b>	20	1	3°42'	L	H1	20	60	80.17	88	90	35
<b>CG4-20L2S</b>	10		20	2	7°25'								
<b>CG4-30L1S</b>	30		30	1	3°42'								
<b>CG4-40L1S</b>	40		40	1	3°42'								
<b>CG4-50L1S</b>	50		50	1	3°42'								
<b>CG4-60L1S</b>	60		60	1	3°42'								

[Caution on Product Characteristics] ① The worm wheel is shifted to fit the mounting distance.

② H2 has a long cast hole in the web (H) section.

③ Products with S at the end of the catalog number are semi-custom stock products. See page 42 for lead times and allowable order quantities. See page 44 for other precautions.

[Precautions for Made to Order Products] ① Prices and lead times for Made to Order products require separate estimates. Contact your dealer.



Total length	Weight (kg)	Catalog Number
R		
95	1.76	<b>SW4-R1</b> <b>SW4-R2</b>
95	1.76	<b>SW4-L1S</b> <b>SW4-L2S</b>

Bronze Worm Wheels & Gray Iron Worm Wheels

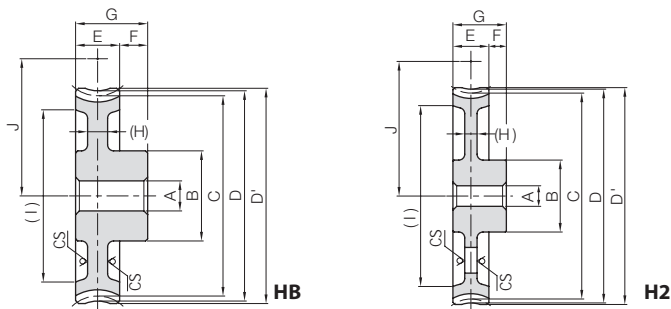

\* CS has a forged finish surface.



Hub width	Total length	Mounting distance	Allowable torque (N·m) <small>NOTE 1</small>						Backlash (mm)	Weight (kg)	Catalog Number
			30 rpm	100 rpm	300 rpm	600 rpm	900 rpm	1200 rpm			
F	G	J	75.9	61.7	47.9	38.4	33.7	30.1	0.17~0.37	1.91	<b>BG4-20R1</b> <b>BG4-20R2</b>
17	52	71	75.9	60.0	44.8	35.7	30.9	27.5			

Hub width	Total length	Web thickness	Web O.D.	Mounting distance	Allowable torque (N·m) <small>NOTE 1</small>				Backlash (mm)	Weight (kg)	Catalog Number
					30 rpm	100 rpm	300 rpm	600 rpm			
17	52	—	—	71	45.6	37.0	28.7	23.0	0.17~0.37	1.56	<b>CG4-20R1</b>
				71	45.5	36.0	26.9	21.4			<b>CG4-20R2</b>
				91	96.3	79.1	62.3	50.9			<b>CG4-30R1</b>
17	52	—	—	91	96.8	78.3	59.4	47.3	0.17~0.37	3.17	<b>CG4-30R2 (Made to Order)</b>
17	52	(11)	(136)	111	165	136	108	89.4	0.17~0.37	4.02	<b>CG4-40R1</b>
17	52	(12)	(176)	131	249	205	165	137	0.17~0.37	4.97	<b>CG4-50R1</b>
				151	348	288	233	194			6.58
17	52	—	—	71	45.6	37.0	28.7	23.0	0.17~0.37	1.56	<b>CG4-20L1S</b>
				71	45.5	36.0	26.9	21.4			<b>CG4-20L2S</b>
				91	96.3	79.1	62.3	50.9			<b>CG4-30L1S</b>
				111	165	136	108	89.4			<b>CG4-40L1S</b>
				131	249	205	165	137			<b>CG4-50L1S</b>
151	348	288	233	194	12.1	<b>CG4-60L1S</b>					

[NOTE 1] Allowable torque based on worm speed (rpm).



Specifications	
Precision grade	KHK W 001 grade 4
Reference section of gear	Normal plane
Gear teeth	Standard full depth
Normal pressure angle	14°30'
Material	S45C
Heat treatment	—
Tooth hardness	(less than 194HB)
Surface treatment	Black oxide coating (excludes semi-custom products)

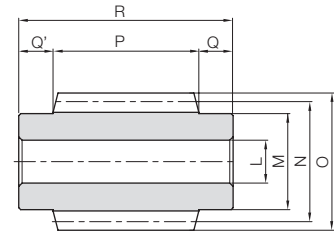

W3

Catalog Number	Normal module	Number of Starts	Nominal lead angle	Direction of helix	Shape	Bore	Hub dia.	Pitch dia.	Outside dia.	Face width	Hub width (right)	Hub width (left)
						L <sub>H7</sub>	M	N	O	P	Q	Q'
<b>SW5-R1</b>	<b>m5</b>	1	4°06'	R	W3	25	56	70	80	85	20	20
<b>SW5-R2 (Made to Order)</b>	<b>m5</b>	2	8°13'	R	W3	25	56	70	80	85	20	20
<b>SW5-L1S</b>	<b>m5</b>	1	4°06'	L	W3	25	56	70	80	85	20	20

[Caution on Product Characteristics] ① Products with S at the end of the catalog number are semi-custom stock products. See page 42 for lead times and allowable order quantities. See page 44 for other precautions.

[Precautions for Made to Order Products] ① Prices and lead times for Made to Order products require separate estimates. Contact your dealer.

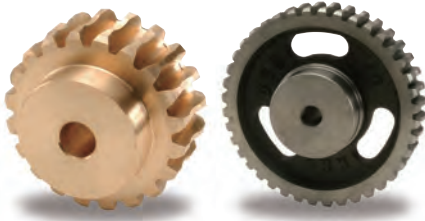

Specifications		
Catalog Number	BG	CG
Precision grade	KHK W 002 grade 4	KHK W 002 grade 4
Reference section of gear	Normal plane	Normal plane
Gear teeth	Standard full depth	Standard full depth
Normal pressure angle	14°30'	14°30'
Material	CAC502 (old JIS PBC2)	FC200
Heat Treatment	—	—
Tooth hardness	—	—

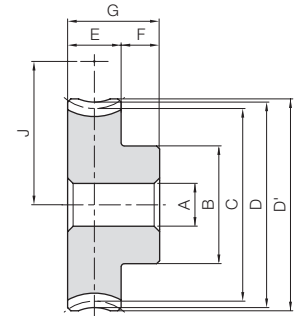

H1

Catalog Number	Reduction ratio	Normal module	No. of teeth	No. of starts of mating worm	Lead angle	Direction of helix	Shape	Bore	Hub dia.	Pitch dia.	Throat dia.	Outside dia.	Face width
								A <sub>H7</sub>	B	C	D	D'	E
<b>BG5-20R1</b>	20	<b>m5</b>	20	1	4°06'	R	H1	22	75	100.26	110	113	45
<b>BG5-20R2 (Made to Order)</b>	10	<b>m5</b>	20	2	8°13'	R	H1	22	75	101.04	110	113	45

Catalog Number	Reduction ratio	Normal module	No. of teeth	No. of starts of mating worm	Lead angle	Direction of helix	Shape	Bore	Hub dia.	Pitch dia.	Throat dia.	Outside dia.	Face width
								A <sub>H7</sub>	B	C	D	D'	E
<b>CG5-20R1</b>	20	<b>m5</b>	20	1	4°06'	R	H1	22	75	100.26	110	113	45
<b>CG5-30R1</b>	30		30	1	4°06'								
<b>CG5-30R2 (Made to Order)</b>	15	<b>m5</b>	30	2	8°13'	R	HB	22	75	151.56	160	163	45
<b>CG5-40R1</b>	40	<b>m5</b>	40	1	4°06'	R	H2	22	90	200.51	210	213	45
<b>CG5-50R1</b>	50	<b>m5</b>	50	1	4°06'	R	H2	22	90	250.61	260	263	45
<b>CG5-60R1</b>	60		60						100	300.77	310	313	
<b>CG5-20L1S</b>	20	<b>m5</b>	20	1	4°06'	L	H1	22	75	100.26	110	113	45
<b>CG5-30L1S</b>	30		30						150.38	160	163		
<b>CG5-40L1S</b>	40		40						200.51	210	213		
<b>CG5-50L1S</b>	50		50						250.64	260	263		
<b>CG5-60L1S</b>	60		60						300.77	310	313		

[Caution on Product Characteristics] ① The worm wheel is shifted to fit the mounting distance.

② H2 has a long cast hole in the web (H) section.

③ Products with S at the end of the catalog number are semi-custom stock products. See page 42 for lead times and allowable order quantities. See page 44 for other precautions.

④ For S semi-custom standard products weighing 15 kg or more, eyebolt screw threads (2-M12 depth 25 mm) are machined around the outside of the hub side surface. Details of the PCD of the screw threads are located on page 51.

[Precautions for Made to Order Products] ① Prices and lead times for Made to Order products require separate estimates. Contact your dealer.



Total length	Weight	Catalog Number
R	(kg)	
125	2.86	<b>SW5-R1</b>
125	2.86	<b>SW5-R2 (Made to Order)</b>
125	2.86	<b>SW5-L1S</b> 

**Bronze Worm Wheels & Gray Iron Worm Wheels**

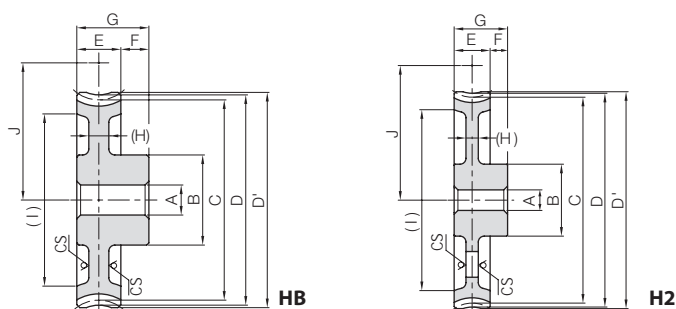

\* CS has a forged finish surface.

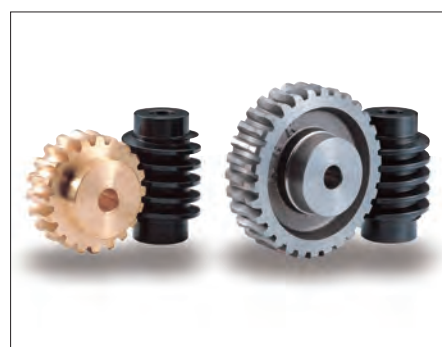

Hub width	Total length	Mounting distance	Allowable torque (N·m) <small>NOTE 1</small>						Backlash (mm)	Weight (kg)	Catalog Number
			30 <sub>rpm</sub>	100 <sub>rpm</sub>	300 <sub>rpm</sub>	600 <sub>rpm</sub>	900 <sub>rpm</sub>	1200 <sub>rpm</sub>			
F	G	J									
20	65	85	146	117	91.2	73.0	63.7	56.9	0.20~0.40	3.89	<b>BG5-20R1</b>
20	65	85	146	115	85.8	68.4	58.8	52.2	0.20~0.40	3.89	<b>BG5-20R2 (Made to Order)</b>

Hub width	Total length	Web thickness	Web O.D.	Mounting distance	Allowable torque (N·m) <small>NOTE 1</small>				Backlash (mm)	Weight (kg)	Catalog Number
					30 <sub>rpm</sub>	100 <sub>rpm</sub>	300 <sub>rpm</sub>	600 <sub>rpm</sub>			
F	G	(H)	(I)	J							
20	65	— (13)	— (127)	85 110	87.4 185	70.3 150	54.7 119	43.8 96.8	0.20~0.40	3.18 5.07	<b>CG5-20R1</b> <b>CG5-30R1</b>
20	65	(13)	(127)	110	187	150	114	90.6	0.20~0.40	5.07	<b>CG5-30R2 (Made to Order)</b>
20	65	(16)	(172)	135	316	258	206	170	0.20~0.40	7.75	<b>CG5-40R1</b>
20	65	(16) (14)	(223) (276)	160 185	477 668	390 548	315 443	261 369	0.20~0.40	10.1 12.3	<b>CG5-50R1</b> <b>CG5-60R1</b>
20	65	—	—	85 110 135 160 185	87.4 185 316 477 668	70.3 150 258 390 548	54.7 119 206 315 443	43.8 96.8 170 261 369	0.20~0.40	3.18 6.44 11.3 17.1 24.4	<b>CG5-20L1S</b> <b>CG5-30L1S</b> <b>CG5-40L1S</b> <b>CG5-50L1S</b> <b>CG5-60L1S</b> 

[NOTE 1] Allowable torque based on worm speed (rpm).

Spur Gears

Helical Gears

Internal Gears

Racks

CP Racks & Pinions

Miter Gears

Bevel Gears

Screw Gears

Worm Gears

Gearboxes

Other Products



Specifications	
Precision grade	KHK W 001 grade 4
Reference section of gear	Normal plane
Gear teeth	Standard full depth
Normal pressure angle	14°30'
Material	S45C
Heat treatment	—
Tooth hardness	(less than 194HB)
Surface treatment	Black oxide coating (excludes semi-custom products)

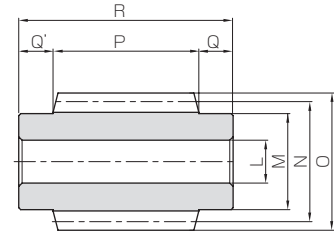

W3

Catalog Number	Normal module	Number of Starts	Nominal lead angle	Direction of helix	Shape	Bore	Hub dia.	Pitch dia.	Outside dia.	Face width	Hub width (right)	Hub width (left)
						L <sub>H7</sub>	M	N	O	P	Q	Q'
<b>SW6-R1</b>	<b>m6</b>	1	4°18'	R	W3	30	64	80	92	100	25	25
<b>SW6-R2 (Made to Order)</b>	<b>m6</b>	2	8°38'	R	W3	30	64	80	92	100	25	25
<b>SW6-L1S</b>	<b>m6</b>	1	4°18'	L	W3	30	64	80	92	100	25	25

[Caution on Product Characteristics] ① Products with S at the end of the catalog number are semi-custom stock products. See page 42 for lead times and allowable order quantities. See page 44 for other precautions.

[Precautions for Made to Order Products] ① Prices and lead times for Made to Order products require separate estimates. Contact your dealer.

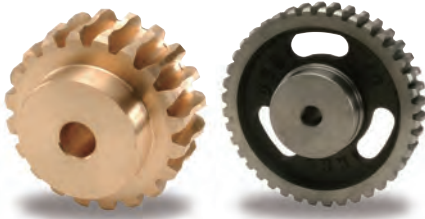

Specifications		
Catalog Number	BG	CG
Precision grade	KHK W 002 grade 4	KHK W 002 grade 4
Reference section of gear	Normal plane	Normal plane
Gear teeth	Standard full depth	Standard full depth
Normal pressure angle	14°30'	14°30'
Material	CAC502 (old JIS PBC2)	FC200
Heat Treatment	—	—
Tooth hardness	—	—

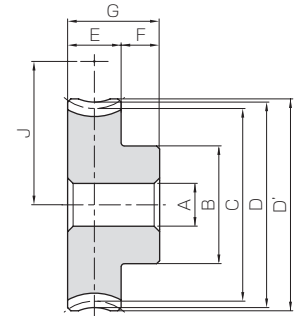

H1

Catalog Number	Reduction ratio	Normal module	No. of teeth	No. of starts of mating worm	Lead angle	Direction of helix	Shape	Bore	Hub dia.	Pitch dia.	Throat dia.	Outside dia.	Face width
								A <sub>H7</sub>	B	C	D	D'	E
<b>BG6-20R1</b>	20	<b>m6</b>	20	1	4°18'	R	H1	25	100	120.34	132	136	52
<b>BG6-20R2 (Made to Order)</b>	10	<b>m6</b>	20	2	8°38'	R	H1	25	100	121.38	132	136	52

Catalog Number	Reduction ratio	Normal module	No. of teeth	No. of starts of mating worm	Lead angle	Direction of helix	Shape	Bore	Hub dia.	Pitch dia.	Throat dia.	Outside dia.	Face width
								A <sub>H7</sub>	B	C	D	D'	E
<b>CG6-20R1</b>	20	<b>m6</b>	20	1	4°18'	R	H1 HB H2	25	100	120.34	132	136	52
<b>CG6-30R1</b>	30		180.51							192	196		
<b>CG6-40R1</b>	40		240.68							252	256		
<b>CG6-50R1</b>	50	<b>m6</b>	50	1	4°18'	H2	100 120	300.85 361.02	312	316	316	52	
<b>CG6-60R1</b>	60		372						376	376			
<b>CG6-20L1S</b>	20	<b>m6</b>	20	1	4°18'	L	H1	25	100	120.34	132	136	52
<b>CG6-30L1S</b>	30		180.51							192	196		
<b>CG6-40L1S</b>	40		240.68							252	256		
<b>CG6-50L1S</b>	50		300.85							312	316		
<b>CG6-60L1S</b>	60		361.02							372	376		

[Caution on Product Characteristics] ① The worm wheel is shifted to fit the mounting distance.

② H2 has a long cast hole in the web (H) section.

③ Products with S at the end of the catalog number are semi-custom stock products. See page 42 for lead times and allowable order quantities. See page 44 for other precautions.

④ For S semi-custom standard products weighing 15 kg or more, eyebolt screw threads (2-M12 depth 25 mm) are machined around the outside of the hub side surface. Details of the PCD of the screw threads are located on page 51.

[Precautions for Made to Order Products] ① Prices and lead times for Made to Order products require separate estimates. Contact your dealer.



Total length	Weight (kg)	Catalog Number
R		
150	4.38	<b>SW6-R1</b>
150	4.38	<b>SW6-R2</b> (Made to Order)
150	4.38	<b>SW6-L1S</b> 



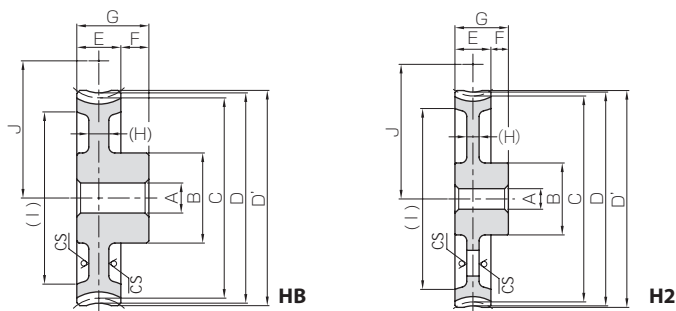

**Bronze Worm Wheels & Gray Iron Worm Wheels**



\* CS has a forged finish surface.



Hub width	Total length	Mounting distance	Allowable torque (N·m) <small>NOTE 1</small>						Backlash (mm)	Weight (kg)	Catalog Number
			30 <sub>rpm</sub>	100 <sub>rpm</sub>	300 <sub>rpm</sub>	600 <sub>rpm</sub>	900 <sub>rpm</sub>	1200 <sub>rpm</sub>			
F	G	J									
20	72	100	232	185	144	115	99.2	88.8	0.22~0.42	6.60	<b>BG6-20R1</b>
20	72	100	235	183	136	109	92.3	82.0	0.22~0.42	6.60	<b>BG6-20R2</b> (Made to Order)

Hub width	Total length	Web thickness	Web O.D.	Mounting distance	Allowable torque (N·m) <small>NOTE 1</small>			Backlash (mm)	Weight (kg)	Catalog Number
					30 <sub>rpm</sub>	100 <sub>rpm</sub>	300 <sub>rpm</sub>			
F	G	(H)	(I)	J						
20	72	—	—	100	139	111	86.2	0.22~0.42	5.39	<b>CG6-20R1</b>
		(15)	(155)	130	294	237	187		8.72	<b>CG6-30R1</b>
		(15)	(213)	160	502	407	325		11.4	<b>CG6-40R1</b>
		(16)	(275)	190	760	615	496		14.5	<b>CG6-50R1</b>
20	72	—	—	220	1060	865	698		20.3	<b>CG6-60R1</b>
				100	139	111	86.2	0.22~0.42	5.39	<b>CG6-20L1S</b> 
				130	294	237	187		10.8	<b>CG6-30L1S</b> 
				160	502	407	325		18.4	<b>CG6-40L1S</b> 
190	760	615	496	28.0	<b>CG6-50L1S</b> 					
				220	1060	865	698		40.3	<b>CG6-60L1S</b> 

[NOTE 1] Allowable torque based on worm speed (rpm).

**S**

Specifications	
Precision grade	KHK W 001 grade 4
Reference section of gear	Normal plane
Gear teeth	Standard full depth
Normal pressure angle	20°
Material	S45C
Heat treatment	—
Tooth hardness	(less than 194HB)
Surface treatment	—

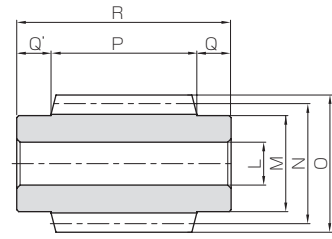
**W3**

Catalog Number	Normal module	Number of Starts	Nominal lead angle	Direction of helix	Shape	Bore	Hub dia.	Pitch dia.	Outside dia.	Face width	Hub width (right)	Hub width (left)
						L <sub>H7</sub>	M	N	O	P	Q	Q'
<b>SW8-R1S</b>	<b>m8</b>	1	5°6'	R	W3	30	68	90	106	120	25	5
<b>SW10-R1S</b>	<b>m10</b>	1	5°44'	R	W3	30	73	100	120	120	25	5

[Caution on Product Characteristics] ① Products with S at the end of the catalog number are semi-custom stock products. See page 42 for lead times and allowable order quantities. See page 44 for other precautions.

**S**

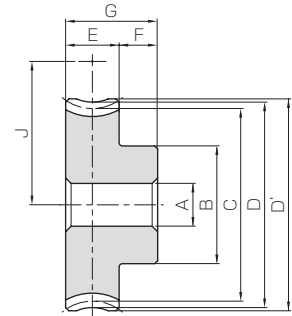

Specifications	
Precision grade	KHK W 002 grade 4
Reference section of gear	Normal plane
Gear teeth	Standard full depth
Normal pressure angle	20°
Material	FC200
Heat treatment	—
Tooth hardness	—
Surface treatment	—

**H1**

Catalog Number	Reduction ratio	Normal module	No. of teeth	No. of starts of mating worm	Lead angle	Direction of helix	Shape	Bore	Hub dia.	Pitch dia.	Throat dia.	Outside dia.	Face width
								A <sub>H7</sub>	B	C	D	D'	E
<b>CG8-20R1S</b>	20	<b>m8</b>	20	1	5°06'	R	H1	30	130	160.64	176	180	60
<b>CG8-30R1S</b>	30		30					180	240.95	256	260		
<b>CG8-40R1S</b>	40		40					220	321.27	336	340		
<b>CG8-50R1S</b>	50		50					240	401.59	416	420		
<b>CG10-20R1S</b>	20	<b>m10</b>	20	1	5°44'	R	H1	30	165	201.01	220	225	72
<b>CG10-30R1S</b>	30		50					240	301.51	320	325		
<b>CG10-40R1S</b>	40		50					280	402.02	420	425		





- [Caution on Product Characteristics] ① The worm wheel is shifted to fit the mounting distance.  
 ② Products with S at the end of the catalog number are semi-custom stock products. See page 42 for lead times and allowable order quantities. See page 44 for other precautions.  
 ③ For S semi-custom standard products weighing 15 kg or more, eyebolt screw threads (2-M12 depth 25 mm) are machined around the outside of the hub side surface. Details of the PCD of the screw threads are located on page 51.



Total length	Weight (kg)	Catalog Number
R		
150	6.02	<b>SW8-R1S</b> 
150	7.55	<b>SW10-R1S</b> 

### Gray Iron Worm Wheels



Hub width	Total length	Mounting distance	Allowable torque (N·m) <small>NOTE 1</small>			Backlash (mm)	Weight (kg)	Catalog Number
			30 rpm	100 rpm	300 rpm			
F	G	J						
35	95	125	288	230	177	0.27~0.51	12.0	<b>CG8-20R1S</b> 
		165	610	492	385		26.2	<b>CG8-30R1S</b> 
		205	1040	843	669		44.4	<b>CG8-40R1S</b> 
		245	1580	1280	1020		66.0	<b>CG8-50R1S</b> 
40	112	150	524	417	320	0.32~0.59	22.8	<b>CG10-20R1S</b> 
		200	1110	893	694		49.5	<b>CG10-30R1S</b> 
		250	1900	1530	1210		83.2	<b>CG10-40R1S</b> 

[NOTE 1] Allowable torque based on worm speed (rpm).

Spur Gears

Helical Gears

Internal Gears

Racks

CP Racks & Pinions

Miter Gears

Bevel Gears

Screw Gears

**Worm Gears**

Gearboxes

Other Products



# Stainless Steel Worms



Specifications	
Precision grade	KHK W 001 grade 4
Reference section of gear	Normal plane
Gear teeth	Standard full depth
Normal pressure angle	20°
Material	SUS303
Heat treatment	—
Tooth hardness	(less than 187HB)

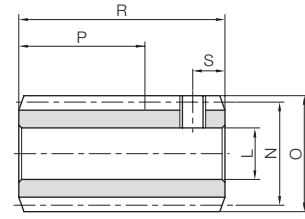

W2

Catalog Number	Normal module	Number of Starts	Nominal lead angle	Direction of helix	Shape	Bore		Hub dia.	Pitch dia.	Outside dia.	Face width	Hub width	Total length
						LH8	M						
SUW0.5-R1 SUW0.5-R2	<b>m0.5</b>	1	2°36'	R	W2	5	—	11	12	(10)	—	—	18
2		5°13'											
SUW0.8-R1 SUW0.8-R2	<b>m0.8</b>	1	3°17'	R	W2	6	—	14	15.6	(18)	—	—	30
2		6°34'											

Spur Gears

Helical Gears

Internal Gears

Racks

CP Racks & Pinions

Miter Gears

Bevel Gears

Screw Gears

Worm Gears

Gearboxes

Other Products



# Worm Wheels



Specifications	
Precision grade	KHK W 002 grade 5 *
Reference section of gear	Normal plane
Gear teeth	Standard full depth
Normal pressure angle	20°
Material	MC901
Heat treatment	—
Tooth hardness	—

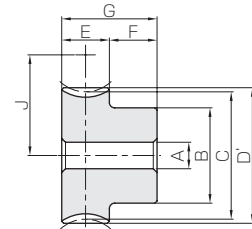

HA

\* The precision grade is equivalent to the value shown in the table.

Catalog Number	Normal module	Reduction ratio	No. of teeth	No. of starts of mating worm	Lead angle helix direction	Shape	A <sup>-0.05</sup> <sub>-0.10</sub>	B	C	D	D'	E	
PG0.5-20R1	<b>m0.5</b>	20	20	1	2°36'	R	HA	4	9	10.01	—	11	5
PG0.5-20R2		10	20	2	5°13'			4	9	10.04		11	
PG0.5-30R1		30	30	1	2°36'			4	12	15.02		16	
PG0.5-30R2		15	30	2	5°13'			4	12	15.06		16	
PG0.5-40R1		40	40	1	2°36'			5	15	20.02		21	
PG0.5-50R1		50	50	1	2°36'			5	20	25.03		26	
PG0.5-60R1		60	60	1				5	25	30.03		31	
PG0.8-20R1	<b>m0.8</b>	20	20	1	3°17'	R	HA	5	12	16.03	—	17.6	9
PG0.8-20R2		10	20	2	6°34'			5	12	16.11		17.6	
PG0.8-30R1		30	30	1	3°17'			5	18	24.04		25.6	
PG0.8-30R2		15	30	2	6°34'			5	18	24.16		25.6	
PG0.8-40R1		40	40	1	3°17'			6	20	32.05		33.6	
PG0.8-50R1		50	50	1	3°17'			8	25	40.07		41.6	
PG0.8-60R1		60	60	1				8	25	48.08		49.6	

[Caution on Product Characteristics] ① The worm wheel is shifted to fit the mounting distance.



Socket head screw		Weight (kg)	Catalog Number
Size	S		
M3	3	0.011	<b>SUW0.5-R1</b>
		0.010	<b>SUW0.5-R2</b>
M4	5	0.029	<b>SUW0.8-R1</b> <b>SUW0.8-R2</b>



Plastic Worm Wheels

F	G	J	Allowable torque (N·m)	Allowable torque (kgf·m)	Backlash (mm)	Weight (kg)	Catalog Number
			Bending strength	Bending strength			
7	12	10.5	0.077	0.0078	0.09~0.17	0.83	<b>PG0.5-20R1</b>
		10.5	0.077	0.0078		0.83	<b>PG0.5-20R2</b>
		13	0.13	0.013		1.82	<b>PG0.5-30R1</b>
		13	0.13	0.013		1.82	<b>PG0.5-30R2</b>
		15.5	0.19	0.019		3.06	<b>PG0.5-40R1</b>
		18	0.24	0.025		5.24	<b>PG0.5-50R1</b>
		20.5	0.31	0.031		7.96	<b>PG0.5-60R1</b>
9	18	15	0.35	0.036	0.13~0.23	3.06	<b>PG0.8-20R1</b>
		15	0.36	0.036		3.06	<b>PG0.8-20R2</b>
		19	0.59	0.060		7.27	<b>PG0.8-30R1</b>
		19	0.60	0.061		7.27	<b>PG0.8-30R2</b>
		23	0.86	0.087		11.51	<b>PG0.8-40R1</b>
		27	1.13	0.12		17.76	<b>PG0.8-50R1</b>
		31	1.41	0.14		23.67	<b>PG0.8-60R1</b>

Spur Gears

Helical Gears

Internal Gears

Racks

CP Racks & Pinions

Miter Gears

Bevel Gears

Screw Gears

Worm Gears

Gearboxes

Other Products



Specifications	
Precision grade	KHK W 001 grade 4*
Reference section of gear	Normal plane
Gear teeth	Standard full depth
Normal pressure angle	20°
Material	SUS303
Heat treatment	—
Tooth hardness	(less than 187HB)

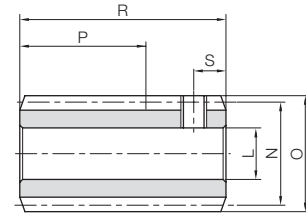

W2

\* The precision grade of J Series products is equivalent to the value shown in the table.

Catalog Number ● : J Series (Available-on-request)	Normal module	Number of Starts	Nominal lead angle	Direction of helix	Shape	Bore	Hub dia.	Pitch dia.	Outside dia.	Face width	Hub width	Total length
						L <sub>H7(H8)</sub>	M	N	O	P	Q	R
SUW1-R1 SUW1-R2	m1	1 2	3°35' 7°11'	R	W2 W2	6 <sub>H8</sub>	—	16	18	(20)	—	32
SUW1.5-R1 ● SUW1.5-R1J8 ● SUW1.5-R1J10	m1.5	1	3°26'	R	W1 W1T W1K	8 8 10	20	25	28	30	10	40
SUW1.5-R2 ● SUW1.5-R2J8 ● SUW1.5-R2J10		2	6°54'		W1 W1T W1K	8 8 10						

[Caution on J series] ① Cancellation is not possible for made-to-order products. See page 42 for lead times and allowable order quantities. See page 44 for other precautions.



Specifications	
Precision grade	KHK W 002 grade 5*
Reference section of gear	Normal plane
Gear teeth	Standard full depth
Normal pressure angle	20°
Material	MC901
Heat treatment	—
Tooth hardness	—

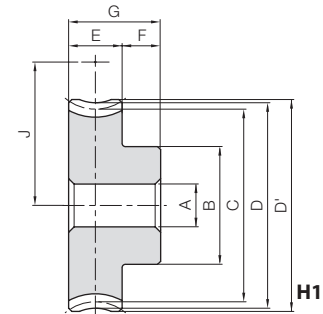

A	Bore
B	Hub dia.
C	Pitch dia.
D	Throat dia.
D'	Outside dia.
E	Face width
F	Hub width
G	Total length
J	Mounting distance

\* The precision grade is equivalent to the value shown in the table.

Catalog Number	Reduction ratio	No. of teeth	No. of starts of mating worm	Lead angle helix direction	Shape	A <sub>H8</sub>	B	C	D	D'	E	F	G	J	Allowable torque (N·m)	Allowable torque (kgf·m)	Backlash (mm)	Weight (kg)	
															Bending strength	Bending strength			
PG1-20R1	20	20	1	3°35'	R	H1	6	16	20.04	22	23			18	0.62	0.060	0~0.28	0.0058	
PG1-20R2	10	20	2	7°11'			6	16	20.16	22	23			18	0.62	0.060		0.0058	
PG1-30R1	30	30	1	3°35'			6	20	30.06	32	33	10	10	20	23	1.03		0.10	0.012
PG1-40R1	40	40	1	3°35'			8	26	40.08	42	43				28	1.49		0.15	0.021
PG1-50R1	50	50	1	3°35'			8	30	50.1	52	53				33	1.96		0.20	0.031
PG1.5-20R1 PG1.5-20R2	20 10	20	1 2	3°26' 6°54'	R	H1	8	22	30.05 30.22	33	34.5	12	10	22	27.5	1.66 1.68	0.17	0~0.30	0.014

[Caution on Product Characteristics] ① The worm wheel is shifted to fit the mounting distance.



J Series

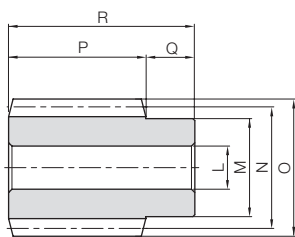

W1

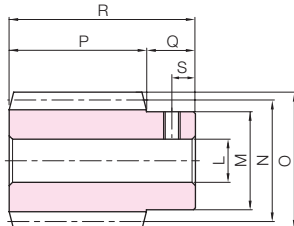

W1T

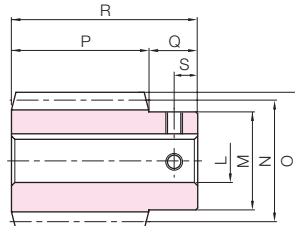

W1K



Keyway Width x Depth	Socket head screw		Weight (kg)	Catalog Number ● : J Series (Available-on-request)
	Size	S		
—	M4	5	0.043	<b>SUW1-R1</b> <b>SUW1-R2</b>
4 x 1.8	—	—	0.13	<b>SUW1.5-R1</b>
	M5	5	0.13	● <b>SUW1.5-R1J8</b>
	M4	5	0.11	● <b>SUW1.5-R1J10</b>
4 x 1.8	—	—	0.13	<b>SUW1.5-R2</b>
	M5	5	0.13	● <b>SUW1.5-R2J8</b>
	M4	5	0.11	● <b>SUW1.5-R2J10</b>



J Series

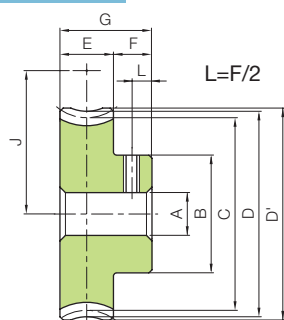

H1T

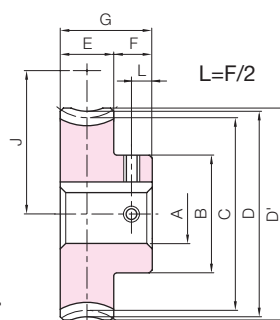

H1K



Plastic Worm Wheels

To order J Series products, please specify: **Catalog No. + J + BORE.**

Bore	* The product shapes of J Series items are identified by background color.							
Keyway Js9	6	8	10	12	14	15	16	17
Screw size	—		4x1.8		5x2.3			
Catalog Number	M4	M5	M4					
PG1-20R1 J BORE								
PG1-20R2 J BORE								
PG1-30R1 J BORE								
PG1-40R1 J BORE								
PG1-50R1 J BORE								
PG1.5-20R1J BORE								
PG1.5-20R2J BORE								

[Caution on J series] ① Cancellation is not possible for made-to-order products. See page 42 for lead times and allowable order quantities. See page 44 for other precautions.

\* In regard to MC Nylon gears, other materials are available for plastic gears, including Ultra High Molecular Weight Polyethylene (U-PE), which has excellent abrasion resistance Poly Ether Ether Ketone (PEEK) also has quality properties. A single piece order is acceptable and will be produced as a custom-made gear. Please see Page 26 for more details on quotations and orders.



# Stainless Steel Worms



Specifications	
Precision grade	KHK W 001 grade 4*
Reference section of gear	Normal plane
Gear teeth	Standard full depth
Normal pressure angle	14°30'
Material	SUS303
Heat treatment	—
Tooth hardness	(less than 187HB)

\* The precision grade of J Series products is equivalent to the value shown in the table.

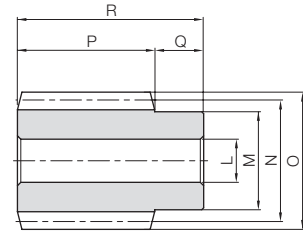

W1

- Spur Gears
- Helical Gears
- Internal Gears
- Racks
- CP Racks & Pinions
- Miter Gears
- Bevel Gears
- Screw Gears
- Worm Gears
- Gearboxes
- Other Products

Catalog Number ● : J Series (Available-on-request)	Normal module	Number of Starts	Nominal lead angle	Direction of helix	Shape	Bore	Hub dia.	Pitch dia.	Outside dia.	Face width	Hub width	Total length
						LH7	M	N	O	P	Q	R
SUW2-R1 ● SUW2-R1J12 ● SUW2-R1J14	m2	1	3°42'	R	W1	12	25	31	35	32	14	46
W1K					12							
W1K		14										
W1		12										
SUW2-R2 ● SUW2-R2J12 ● SUW2-R2J14	m2	2	7°25'	R	W1	12	35	44	50	50	20	70
W1K					12							
W1K		14										
W1		16										
SUW3-R1 ● SUW3-R1J17 ● SUW3-R1J18 ● SUW3-R1J19 ● SUW3-R1J20	m3	1	3°55'	R	W1	16	35	44	50	50	20	70
W1K					17							
W1K		18										
W1K		19										
SUW3-R2 ● SUW3-R2J17 ● SUW3-R2J18 ● SUW3-R2J19 ● SUW3-R2J20	m3	2	7°50'	R	W1	16	35	44	50	50	20	70
W1K					17							
W1K		18										
W1K		19										

[Caution on J series] ① Cancellation is not possible for made-to-order products. See page 42 for lead times and allowable order quantities. See page 44 for other precautions.



# Worm Wheels



Specifications	
Precision grade	KHK W 002 grade 5*
Reference section of gear	Normal plane
Gear teeth	Standard full depth
Normal pressure angle	14°30'
Material	MC901
Heat treatment	—
Tooth hardness	—

\* The precision grade is equivalent to the value shown in the table.

A	Bore
B	Hub dia.
C	Pitch dia.
D	Throat dia.
D'	Outside dia.
E	Face width
F	Hub width
G	Total length
J	Mounting distance

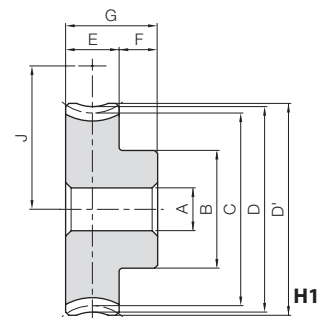

Catalog Number	Reduction ratio	No. of teeth	No. of starts of mating worm	Lead angle helix direction	Shape	A <sub>H8</sub>	B	C	D	D'	E	F	G	J	Allowable torque (N·m)	Allowable torque (kgf·m)	Backlash (mm)	Weight (kg)
															Bending strength	Bending strength		
PG2-20R1 PG2-20R2	20 10	20 20	1 2	3°42' 7°25'	R	H1	10 33	40.08 40.34	44	46	22	13	35	35.5	4.78 4.82	0.49 0.49	0~0.33	0.046
PG3-20R1 PG3-20R2	20 10	20 20	1 2	3°55' 7°50'	R	H1	15 50	60.14 60.57	66	69	28	15	43	52	(13.7) (13.8)	1.40 1.41	0~0.38	0.13

[Caution on Product Characteristics] ① The worm wheel is shifted to fit the mounting distance.



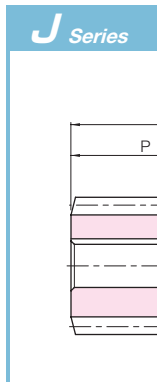

Keyway Width × Depth	Socket head screw		Weight (kg)	Catalog Number ● : J Series (Available-on-request)
	Size	S		
—	—	—	0.20	<b>SUW2-R1</b>
4 x 1.8	M4	7	0.20	● <b>SUW2-R1J12</b>
5 x 2.3	M4	7	0.18	● <b>SUW2-R1J14</b>
—	—	—	0.20	<b>SUW2-R2</b>
4 x 1.8	M4	7	0.20	● <b>SUW2-R2J12</b>
5 x 2.3	M4	7	0.18	● <b>SUW2-R2J14</b>
—	—	—	0.64	<b>SUW3-R1</b>
5 x 2.3	M4	10	0.62	● <b>SUW3-R1J17</b>
6 x 2.8	M5	10	0.60	● <b>SUW3-R1J18</b>
6 x 2.8	M5	10	0.59	● <b>SUW3-R1J19</b>
6 x 2.8	M5	10	0.57	● <b>SUW3-R1J20</b>
—	—	—	0.64	<b>SUW3-R2</b>
5 x 2.3	M4	10	0.62	● <b>SUW3-R2J17</b>
6 x 2.8	M5	10	0.60	● <b>SUW3-R2J18</b>
6 x 2.8	M5	10	0.59	● <b>SUW3-R2J19</b>
6 x 2.8	M5	10	0.57	● <b>SUW3-R2J20</b>



Spur Gears

Helical Gears

Internal Gears

Racks

CP Racks & Pinions

Miter Gears

Bevel Gears

Screw Gears

Worm Gears

Gearboxes

Other Products

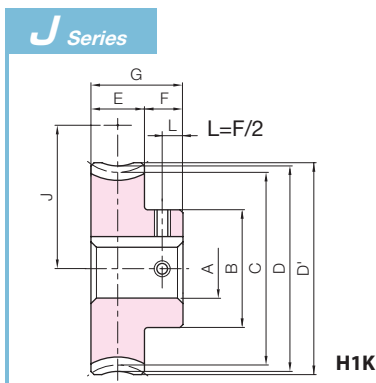

Plastic Worm Wheels



To order J Series products, please specify: **Catalog No. + J + BORE.**

Bore	* The product shapes of J Series items are identified by background color.												
Keyway Js9	10	12	14	15	16	17	18	19	20	22	25	28	30
Screw size	4x1.8			5x2.3				6x2.8				8x3.3	
Catalog Number	M4						M5				M6		
PG2-20R1 J BORE													
PG2-20R2 J BORE													
PG3-20R1 J BORE													
PG3-20R2 J BORE													

[Caution on J series] ① Cancellation is not possible for made-to-order products. See page 42 for lead times and allowable order quantities. See page 44 for other precautions.

# Custom-made worm gears are available.

KHK offers high-precision products.



- ◆ Production Range
- Module : 0.5~10
- Assembly distance : 350 mm or less
- Worm outer diameter :  $\phi$  100 mm or less
- Total length : 600 mm or less
- Weight : 25kg or less
- Wheel outer diameter :  $\phi$  600 mm or less
- Weight : 200kg or less

High-precision ground gear technology achieves high speed and quiet movement.

Excellent tooth contact and appropriate backlash are essential for worm gears. Give KHK's reliable stock worm gears a try.

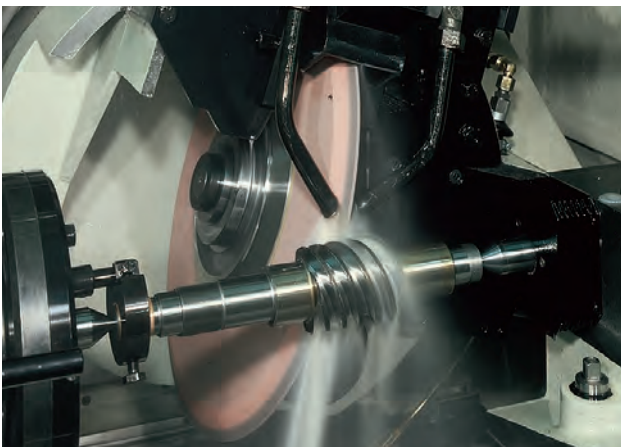

Custom-made Worm Grinding Machine



Worm Gear Tooth Contact Machine