

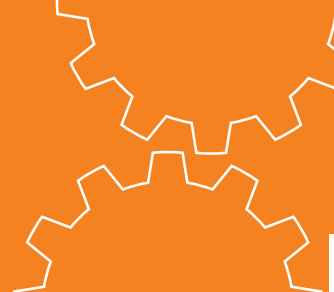

Bevel Gears



MHP High-Ratio Hypoid Gears Gear Ratio 15-60  Material: SCM415 m1, 1.5 Page 346	MBSG Ground Spiral Bevel Gears Gear Ratio 2  Material: SCM415 m2-4 Page 350	SBSG Ground Spiral Bevel Gears Gear Ratio 1.5-3  Material: S45C m2-4 Page 352	MBSA/MBSB Finished Bore Spiral Bevel Gears Gear Ratio 1.5-3  Material: SCM415 m2-6 Page 354	SBS Spiral Bevel Gears Gear Ratio 1.5-4  Material: S45C m1-5 Page 358	SB-H Hardened Bevel Gears Gear Ratio 1.5-4 NEW H  Material: S45C m1-6 Page 362	SB Bevel Gears Gear Ratio 1.5-4  Material: S45C m1-6 Page 362	SBY-H Hardened Bevel Gears Gear Ratio 2-4 NEW H  Material: S45C m5-8 Page 362
SBY Bevel Gears Gear Ratio 2-4  Material: S45C m5-8 Page 362	SB-H Hardened Steel Bevel Gears & Pinion Shafts Gear Ratio 5 NEW H  Material: S45C m1.5-3 Page 366	SB Steel Bevel Gears & Pinion Shafts Gear Ratio 5  Material: S45C m1.5-3 Page 366	SUB Stainless Steel Bevel Gears Gear Ratio 1.5-3  Material: SUS303 m1.5-3 Page 368	PB Plastic Bevel Gears Gear Ratio 1.5-3  Material: MC901 m1-2 Page 370	DB Injection Molded Bevel Gears Gear Ratio 2  Material: Duracon (R) (M90-44) m0.5-1 Page 372	BB Sintered Metal Bushings  Material: Oil-free copper alloy φ 5-6 Page 372	Nissei KSP Ground Spiral Bevel Gears Gear Ratio 1-2  Material: SCM415 m1.5-6 Page 374

- Spur Gears
- Helical Gears
- Internal Gears
- Racks
- CP Racks & Pinions
- Miter Gears
- Bevel Gears
- Screw Gears
- Worm Gears
- Gearboxes
- Other Products

Catalog Number of KHK Stock Gears

The Catalog Number for KHK stock gears is based on the simple formula listed below. Please order KHK gears by specifying the Catalog Numbers.

(Example) Bevel Gears

M B S G 2 - 40 20 R





Features



KHK stock bevel gears are available in two types, spiral bevel gears and straight bevel gears, in gear ratios of 1.5 through 5, and are offered in a large variety of modules, numbers of teeth, materials and styles. The following table lists the main features for easy selection.

Type	Catalog Number	Module	Gear Ratio	Material	Heat Treatment	Tooth Surface Finish	Precision JIS B 1704: 1978	Secondary Operations	Features
Hypoid Gear	MHP	1, 1.5	15~60	SCM415	Carburized Note 1	Cut	3	△	Hypoid gears that have been tempered and hardened that are capable of rapid deceleration.
Spiral Bevel Gears	MBSG	2~4	2	SCM415	Carburized Note 1	Ground	1	△	Gears that have been hardened and ground that has excellent accuracy, strength and abrasion resistance. Secondary operations are possible except for the teeth.
	SBSG	2~4	1.5~3	S45C	Gear teeth induction hardened	Ground	2	△	Gears that has been hardened and ground with a good balance of accuracy, wear resistance and cost. Secondary operations are possible except for the teeth.
	KSP	1.5~6	1~2	SCM415	Carburized Note 1	Ground	0	△	Gears that have been hardened and ground that has grade-0 accuracy, strength, abrasion resistance and quietness. Secondary operations can be given except for the teeth.
	MBSA/MBSB	2~6	1.5~3	SCM415	Carburized Note 1	Cut	4	×	Gears that have been fully hardened that have excellent strength and wear resistance. Can be used in the finished shape.
	SBS	1~5	1.5~4	S45C	Gear teeth induction hardened	Cut	4	△	Gears that have been hardened with excellent wear resistance. Secondary operations are possible except for the teeth.
Straight Bevel Gears	SB/SBY	1~8	1.5~5	S45C	—	Cut	3	○	Many lineups are available at a low price. The teeth can be additionally hardened.
	SUB	1.5~3	1.5~3	SUS303	—	Cut	3	○	Stainless steel gears with rust resistance.
	PB	1~2	1.5~3	MC901	—	Cut	4	○	Nylon gears can be used with no lubrication.
	DB	0.5~1	2	Duracon (R) (M90-44) NOTE 2	—	Injection Molded	6	△	Low-priced gears made through injection molding. Suitable for light loads.

[NOTE 1] Although these are carburized products, secondary operations can be performed on the areas that are masked during the carburization. However, note that high hardness (HRC40 at maximum) occurs in some cases.

[NOTE 2] "Duracon (R)" is a registered trademark of Polyplastics Co., Ltd. in Japan as well as other countries.

○ Possible △ Partly possible × Not possible

Application Examples



Bevel gears are used as power transmission components of intersecting axes.

■ Differential Gear Mechanism Example



Image provided by: PK Design

■ SHESCO 2WD Bike

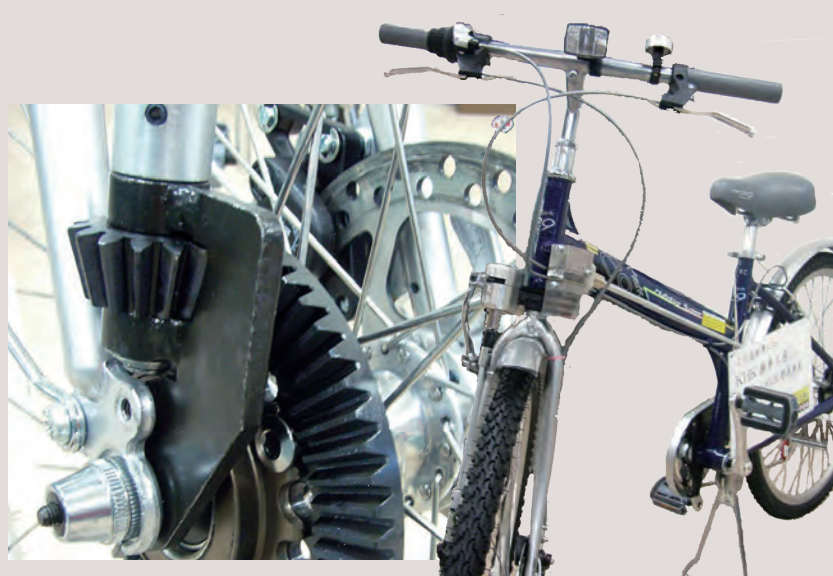

SB Bevel Gears are used in the driving components in both the front and rear wheels

Selection Hints



Please select the most suitable products by carefully considering the characteristics of items and contents of the product tables. It is also important to read all applicable "CAUTION" notes shown below before the final selection.

1. Caution in Selecting the Mating Gears

Basically, KHK stock bevel gears should be selected as shown in the catalog in pairs (e.g. MBSG2-4020R should mate with MBSG2-2040L). But, for straight tooth bevel gears, there is some interchangeability with different series. For plastic bevel gears, we recommend metal mating gears for good heat conductivity.

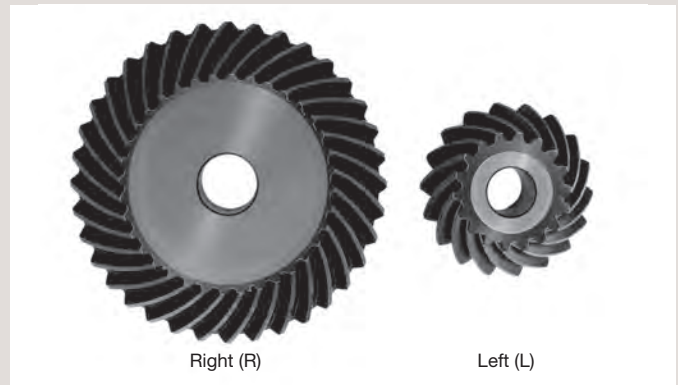

■ Selection Chart for Straight Bevel Gears (○ Allowable × Not allowable)

Gears Pinion \	SB SBY	SUB	PB	DB
SB-SBY	○	○	○	×
SUB	○	○	○	×
PB	○	○	○	×
DB	×	×	×	○

■ Selection Chart for Spiral Bevel Gears (○ Allowable × Not allowable)

Gears Pinion \	MBSG	SBSG	MBSA MBSB	SBS
MBSG	○	×	×	×
SBSG	×	○	×	×
MBSA/MBSB	×	×	○	×
SBS	×	×	×	○

2. Caution in Selecting Gears Based on Gear Strength

The gear strength values shown in the product pages were computed by assuming the application environment in the table below. Therefore, they should be used as reference only. We recommend that each user computes their own values by applying the actual usage conditions.

■ Calculation of Bending Strength of Gears

Item \ Catalog Number	MBSG MBSA MBSB	SBSG/SBS	SB ^{NOTE 2} SBY	SB-H SBY-H	SUB	PB	DB
Formula ^{NOTE 1}	Formula of bevel gears on bending strength (JGMA403-01)					The Lewis formula	
No. of teeth of mating gears	No. of teeth of the mating gear of the set					—	
Rotational Speed of Pinion	100rpm (600rpm for MBSG and SBSG)					100rpm	
Design Life (Durability)	Over 10 ⁷ cycles					—	
Impact from motor	Uniform load					Allowable bending stress (kgf/mm ²)	
Impact from load	Uniform load						
Direction of load	Bidirectional load (calculated with allowable bending stress of 2/3)						
Allowable bending stress at root σ_{Fim} (kgf/mm ²)	47	21	19 (24.5)	19	10.5	1.15 (40°C with No Lubrication)	<i>m</i> 0.5 4.0 <i>m</i> 0.8 4.0 <i>m</i> 1.0 3.5 (40°C with Grease Lubrication)
Safety factor K_R	1.2						

■ Calculation of Surface Durability (Except where it is common with bending strength)

Formula ^{NOTE 1}	Formula of bevel gears on surface durability (JGMA404-01)				
Kinematic viscosity of lubricant	100cSt (50°C)				
Gear support	Shafts & gear box have normal stiffness, and gears are supported on one end				
Allowable Hertz stress σ_{Hlim} (kgf/mm ²)	166	90	49 (62.5)	90	41.3
Safety factor C_R	1.15				

[NOTE 1] The gear strength formula is based on JGMA (Japanese Gear Manufacturers Association) specifications, "MC Nylon Technical Data" by Mitsubishi Chemical Advanced Materials and "Duracon (R) Gear" by Polyplastics Co. The units for the rotational speed (rpm) and the stress (kgf/mm²) are adjusted to the units needed in the formula.

[NOTE 2] Since SB Bevel Pinion Shafts are thermally refined, the allowable tooth-root bending stress and allowable hertz stress are the value shown in parentheses.



Product Precautions



Common Notes

[Caution on Product Characteristics]

- (1) The allowable torque shown in the table are calculated values according to the assumed usage conditions. Please see Page 341 for more details.
- (2) Dimensions of the outside diameter, the total length and crown to back length are all theoretical values, and some differences will occur due to the corner chamfering of the gear tips.
- (3) These bevel gears produce axial thrust forces. Please see Page 344 for more details.
- (4) Variations in temperature or humidity can cause dimensional changes in plastic gears, including tooth diameter, bore, and backlash. The accuracy and tolerances shown in the catalog are values obtained when machining is performed.
- (5) Keyways are made according to JIS B1301 standards, Js9 tolerance. Also note that keyway tooth position alignment is not performed.
- (6) For products having a tapped hole, a set screw is included. (excludes B7)
- (7) See Page 22 for more details on Hardened Plus (H Series and HJ Series).
 - KHK's Specifications for Heat Treatment
 - Hardened location: Tooth surface, or Tooth surface and Tooth root
 - Hardness: 50 to 60 HRC
 - * Hardness and Depth of Gear-teeth Induction Hardening
 - The hardening method and the state of the hardened teeth area vary depending on the size of gears.
 - Since different hardening treatment is applied in accordance with the module and number of teeth, the hardness level is referred to as the hardness of the reference diameter.
 - For some of our products, the hardness at tooth tip / root may not be equal to the hardness you designated.
 - As to the effective case depth, it is specified by JIS, as "The distance from the surface of the case to the area with hardness HV450." The case depth differs from area to area of a tooth, so the depth cannot be specified.
 - Due to the gear teeth being induction hardened, no secondary operations can be performed on tooth areas including the bottom land (approx. 2 to 3 mm).

MEMO

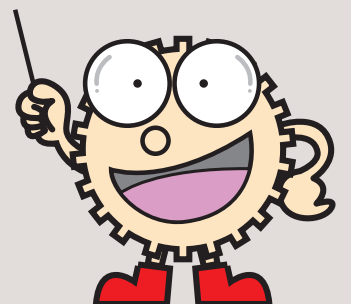



Application Hints



In order to use KHK stock bevel gears safely, carefully read the Application Hints before proceeding.

If there are questions or you require clarifications, please contact our technical department or your nearest distributor.

E-mail: info@khkgears.net

Please read "Cautions on Performing Secondary Operations" below when performing modifications and/or secondary operations for safety concerns.

1. Cautions on Handling

- ① KHK products are packaged one by one to prevent scratches and dents, but if you find issues such as rust, scratches, or dents when the product is removed from the box after purchase, please contact the supplier.
- ② Depending on the handling method, the product may become deformed or damaged. Plastic gears and ring gears deform particularly easily, so please handle with care.

2. Caution on Performing Secondary Operations

- ① If reboring, it is important to pay special attention to locating the center in order to avoid runout.
- ② The reference datum for gear machining is the bore. Therefore, use the bore for locating the center. If it is too difficult to do for small bores, the alternative is to use one spot on the bore and the runout of the side surface.
- ③ If reworking using scroll chucks, we recommend the use of new or rebores jaws for improved precision. Please exercise caution not to crush the teeth.

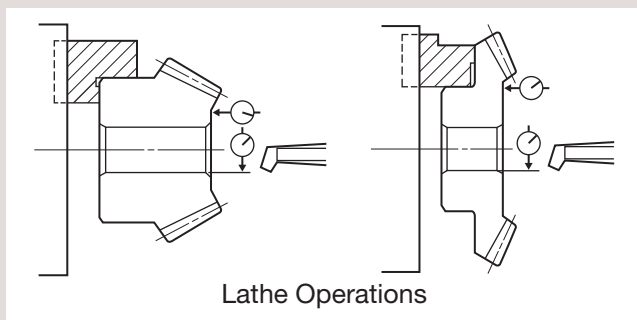

- ④ For items with induction hardened teeth, the hardness is high near the tooth root. When machining the front face, the machined area should be 4 to 6mm smaller than the holding surface diameter dimensions.

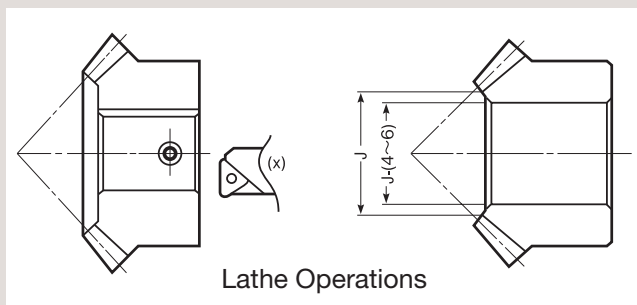

- ⑤ For tapping and keyway operations, see the examples given in "Caution on Performing Secondary Operations" in KHK Stock Spur Gear section. When cutting keyways, to avoid stress concentration, always round the corners.
- ⑥ PB plastic bevel gears are susceptible to changes due to temperature and humidity. Dimensions may change between, during, and after re-machining operations.

- ⑦ When induction-hardening S45C products, thermal stress cracks may appear. Also, note that the precision grade of the product declines by 1 or 2 grades, as deformation on material may occur. If you require tolerance for bore or other parts, machining is necessary after heat treatment.

- ⑧ For the handling conveniences, the SB and SBY series listed below have the tapped holes (180° apart, 2 places) on the holding surface. We appreciate your understanding.

Please pay attention to the machining position.

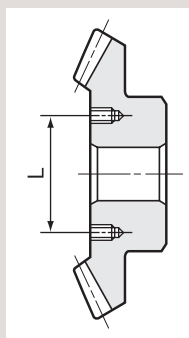

Catalog Number	L(mm)	Tap Size
SB6-4515	130	M10 deep 20
SBY8-4020	160	M10 deep 20
SBY8-4515	210	M10 deep 20
SBY5-6015	160	M10 deep 20
SBY6-6015	220	M10 deep 20

3. Points of Caution during Assembly

- ① Since bevel gears are cone shaped, they produce axial thrust forces. Especially for spiral bevel gears, the directions of thrust change with the hand of helix and the direction of rotation. This is illustrated below. The bearings must be selected properly to be able to handle these thrust forces. For details, use gear calculation software GCSW.

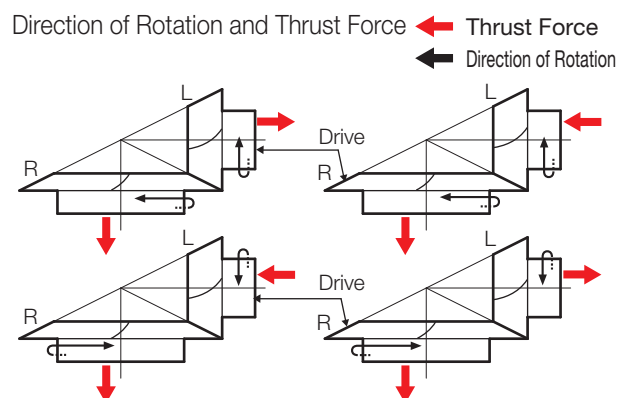

[NOTE] Bevel gears with the gear ratio 1.57 or less, produce a thrust force which is the same as miter gears. For details, please see Page 308.

- ② If a gear is mounted on a shaft far from the bearings, the shaft may bend. We recommend designing bevel gears to be as close to the bearings as possible. Design the gear box, shaft and bearing with high rigidity.
- ③ Be sure to fasten the bevel gear to prevent the gears from moving, as thrust acts on it while rotating.

- ④ When installing MBSA or MBSB spiral bevel gears produced in B7 style (ring gear), always secure the gears onto the mounting base with taper pins to absorb the rotational loads. It is dangerous to secure with bolts only.

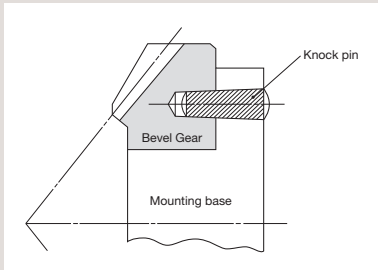

- ⑤ The recommended assemble distance tolerance of KHK stock bevel gears is H7 for ground gears and H8 for cut gears. Mounting distance error, offset error and shaft angle error must be minimized to avoid excessive noise and wear. Inaccurate assembly will lead to irregular noises and uneven wear. Various conditions of tooth contact are shown below. Also, when changing the normal direction backlash, adjust the mounting distance according to the amount of axial movement shown in the table below so as not to change the tooth contact.

Gear Ratio (Reduction Ratio)	Normal direction backlash	Travel in axial direction	
		Pinion	Gears
1.5	j_n	$0.81 \times j_n$	$1.22 \times j_n$
2		$0.65 \times j_n$	$1.31 \times j_n$
2.5		$0.54 \times j_n$	$1.36 \times j_n$
3		$0.46 \times j_n$	$1.39 \times j_n$
4		$0.35 \times j_n$	$1.42 \times j_n$
5		$0.29 \times j_n$	$1.43 \times j_n$
15 or more		$1.4 \times j_n \div \text{Gear Ratio}$	$1.4 \times j_n$

4. Cautions on Starting

- Check the following items before starting.
 - Are the gears fastened securely?
 - Is there uneven tooth contact?
 - Is there adequate backlash?
(Be sure to avoid zero-backlash.)
 - Has proper lubrication been supplied?
- If gears are exposed, be sure to attach a safety cover to ensure safety. Also, be careful not to touch rotating gears.
- If there is any abnormality such as noise or vibration during startup, stop the operation immediately and check the assembly condition such as tooth contact, eccentricity and looseness.

Correct Tooth Contact

- When assembled correctly, the contact will occur on both gears in the middle of the flank and center of face width but somewhat closer to the toe.

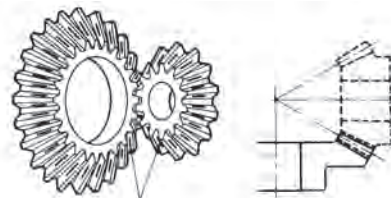

Center contact closer to toes

Incorrect Tooth Contact

■ Mounting Distance Error

- When the mounting distance of the pinion is incorrect, the contact will occur too high on the flank on one gear and too low on the other.

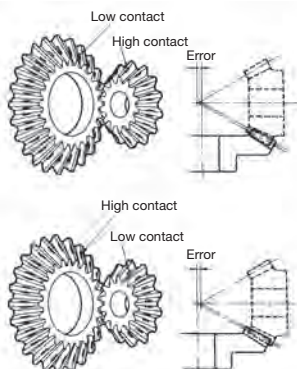

■ Offset Error

- When the pinion shaft is offset, the contact surface is near the toe of one gear and near the heel of the other.

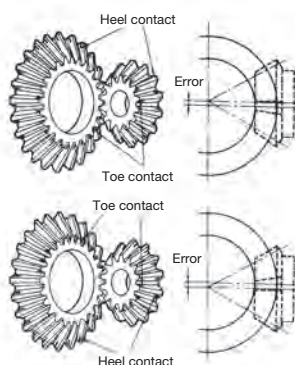

■ Shaft Angle Error

- When there is an angular error of shafts, the gears will contact at the toes or heels depending on whether the angle is greater or less than 90°.

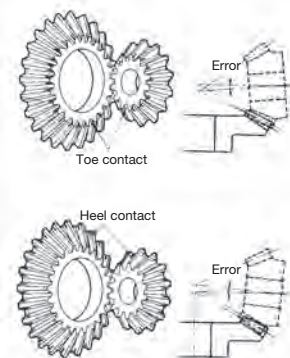



Features of MHP High Ratio Hypoid Gears

A pair of MHP high-ratio hypoid gears are able to produce an amazing reduction of speed of 60:1 in one stage.

1. Total-cost reduction

The MHP provides a compact gearing body replacing several stages of reduction gears. This reduces the cost sharply.

2. High efficiency

Compared to worm gear drives, the MHP has less sliding contact. The resulting higher efficiency allows the use of smaller motors. (See graph on the right)

3. High rigidity

The carburized hypoid gears lead to smaller size than comparable worms gears.

4. Compact gear assembly

The size of the gear housing is nearly the same as outer diameter of the large gear. (See the diagrams below)

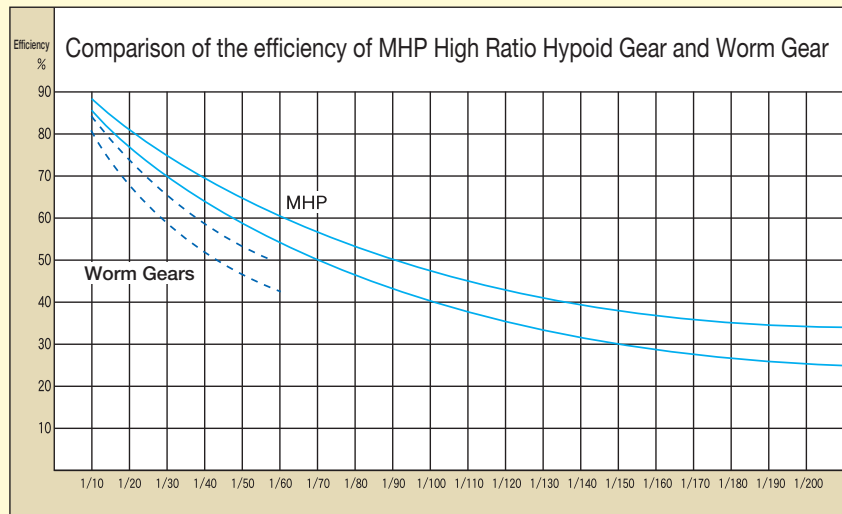

How to determine the radial and thrust loads

Before using the MHP high-ratio hypoid gears, be sure to confirm the direction of radial and thrust loads. Following equations are used to compute these loads. The radial and thrust load coefficients are given on the product pages.

Comparison of MHP and Worm Gear

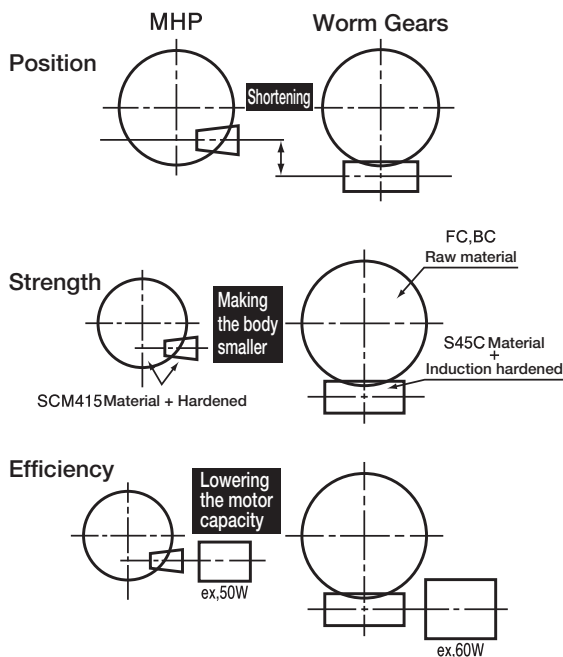

Radial load calculation

W_{RP} : Radial load on the pinion or L(N)

$$W_{RP} = W_{KP} \times T_G \times \frac{n}{z}$$

W_{KP} : Radial load coefficient of pinion or L (given on the product pages)

T_G : Torque of gear or R(N·m)

n : Number of teeth of pinion or L

z : Number of teeth of gear or R

W_{RG} : Radial load on the gear or R(N)

$$W_{RG} = W_{KG} \times T_G$$

W_{KG} : Radial load coefficient of gear or R (given on the product pages)

T_G : Torque of gear or R(N·m)

Thrust load

W_{XP} : Thrust load on the pinion or L(N)

$$W_{XP} = W_{NP} \times T_G \times \frac{n}{z}$$

W_{NP} : Thrust load coefficient of pinion or L (given on the product page)

T_G : Torque of gear or R(N·m)

n : Number of teeth of pinion or L

z : Number of teeth of gear or R

W_{XG} : Thrust load of gear or R(N)

$$W_{XG} = W_{NG} \times T_G$$

W_{NG} : Thrust load coefficient of gear or R (given on the product pages)

T_G : Torque of gear or R(N·m)

Variations in tooth contact due to poor alignment of gears

If the gear engagement position is out of the normal position, variations in tooth contact, as illustrated below, may appear.

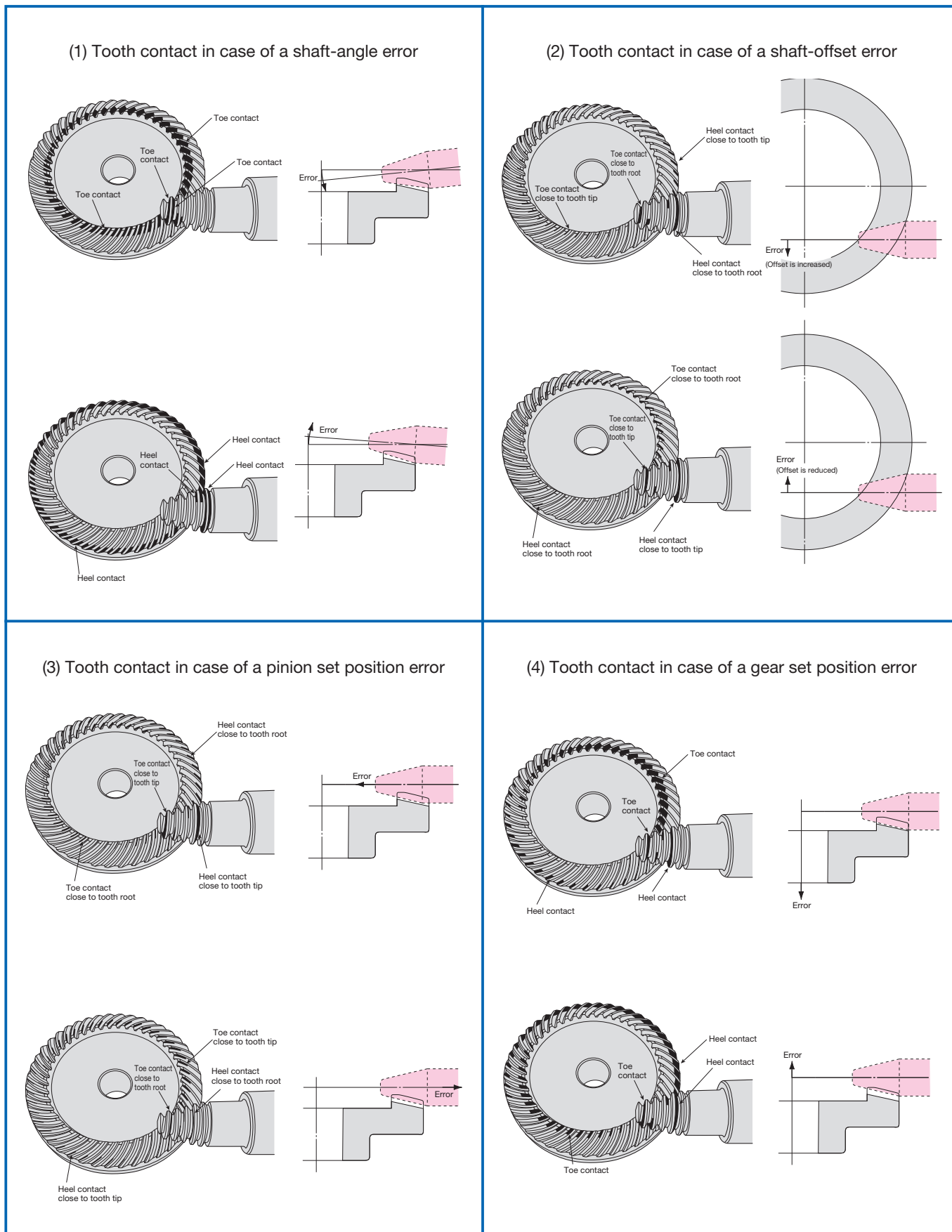

Spur Gears

Helical Gears

Internal Gears

Racks

CP Racks & Pinions

Miter Gears

Bevel Gears

Screw Gears

Worm Gears

Gearboxes

Other Products



Spur Gears

Helical Gears

Internal Gears

Racks

CP Racks & Pinions

Miter Gears

Bevel Gears

Screw Gears

Worm Gears

Gearboxes

Other Products



Specifications	
Precision grade	JIS B 1704: 1978 grade 3
Gear teeth	Gleason
Pressure angle	20°*
Material	SCM415
Heat treatment	Carburized **
Tooth hardness	60 to 63HRC

* 22°30' for MHP1.5-0453R/3045L and MHP1.5-0451R/1045L
 ** In the illustration, the area surrounded with ---- line is masked during the carburization process (max. HRC40 or so) and can be modified.

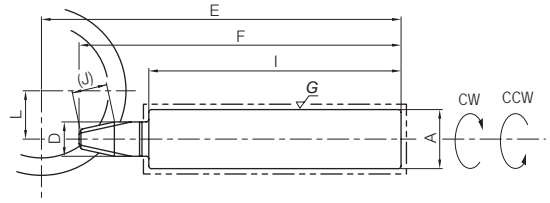

B8

Catalog Number	Reduction ratio	Nominal module	Actual module	No. of teeth	Direction of spiral	Shape	Bore/Shaft Dia.	Hub dia.	Pitch dia.	Outside dia.	Mounting distance	Total length	Hub width	Length of bore and shaft
							A (Bore: H7/Shaft: h7)	B	C	D	E	F	H	I
MHP1-0453R MHP1-3045L	15	m1	1.067	45 3	R L	B9 B8	12 22.1	30 —	48 10.3	48 10.3	19 127	16.3 113	7 —	14 94
MHP1.5-0453R MHP1.5-3045L	15	m1.5	1.733	45 3	R L	B9 B8	14 31.1	40 —	78 17.6	78 17.6	28 170	23.7 148	10 —	20 116
MHP1.5-0603R MHP1.5-3060L	20	m1.5	1.633	60 3	R L	B9 B8	20 36.1	50 —	98 15.7	98 15.7	33 199	28.7 168	13 —	25 135
MHP1-0602R MHP1-2060L	30	m1	1.05	60 2	R L	B9 B8	12 22.1	34 —	63 12.8	63 12.8	21 134	17.8 120	8 —	16 94
MHP1-0451R MHP1-1045L	45	m1	1.067	45 1	R L	B9 B8	12 20.1	30 —	48 10.1	48 10.1	19 115	16.5 104	7 —	14 85
MHP1.5-0451R MHP1.5-1045L	45	m1.5	1.733	45 1	R L	B9 B8	14 26.1	40 —	78 18.3	78 18.3	28 152	23.9 138	10 —	20 102
MHP1-0601R MHP1-1060L	60	m1	1.05	60 1	R L	B9 B8	12 22.1	34 —	63 12.9	63 12.9	21 134	17.9 122	8 —	16 94
MHP1.5-0601R MHP1.5-1060L	60	m1.5	1.633	60 1	R L	B9 B8	20 31.1	50 —	98 17.7	98 17.7	33 175	28.2 151	13 —	25 116

[Caution on Product Characteristics] ① Radial and thrust load coefficients are the factors used for calculation of those loads. As shown in the figure B8, CW and CCW stand for clockwise and counterclockwise rotation. A plus sign means that the two gears in a set move away each other when load is applied. A minus sign means that two gears in a set approach each other when load is applied. Please see Page 346 for more details.

Product Precautions → **Page 342**

Helix Hands and Offset Position

MHP High Ratio Hypoid Gears are designed to be right hand helix for gears, left hand helix for pinions. The opposite helix hand gears are not available for these products. Also, the offset position is already set, so please refer to the illustration below when designing or assembling.

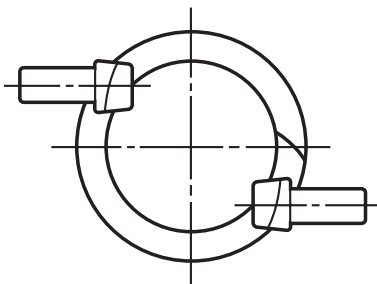

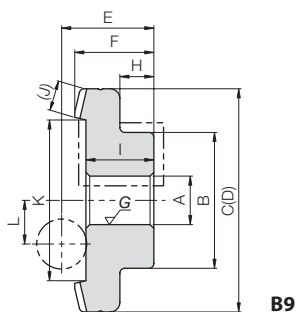

B9

Face width (J)	Holding surface dia. K	Offset L	Radial load coefficient		Thrust load coefficient		Backlash (mm)	Weight (kg)	Catalog Number
			CW	CCW	CW	CCW			
(6)	35.1 —	10	48.48 147.3	-37.67 523.74	13 969.92	31.74 -831.16	0.05~0.15	0.15 0.29	MHP1-0453R MHP1-3045L
(10)	56.5 —	18	26.78 100.09	-18.67 338.45	8.98 566.72	21.19 -466.63	0.10~0.20	0.50 0.73	MHP1.5-0453R MHP1.5-3045L
(10)	76.8 —	22	20.44 119.32	-16.54 302.18	7.15 577.56	13.95 -511.77	0.10~0.20	0.94 1.15	MHP1.5-0603R MHP1.5-3060L
(8)	46.4 —	18	33.59 186.59	-24.15 784.31	8.21 1461.23	24.77 -1248.6	0.05~0.15	0.29 0.28	MHP1-0602R MHP1-2060L
(6)	34.9 —	14	48.04 400.81	-35.58 1579.79	11.13 3014.6	34.11 -2605.26	0.05~0.15	0.16 0.22	MHP1-0451R MHP1-1045L
(10)	56 —	25	26.36 233.59	-16.04 1034.08	6.88 1755.84	22.02 -1439.58	0.10~0.20	0.50 0.48	MHP1.5-0451R MHP1.5-1045L
(8)	46.3 —	20	33.34 357.61	-23.12 1564.81	7.41 2936.72	25.14 -2514.09	0.05~0.15	0.29 0.28	MHP1-0601R MHP1-1060L
(10)	76.8 —	30	22.63 303.06	-17.19 974.4	5.82 1912.11	15.81 -1675.65	0.10~0.20	0.94 0.77	MHP1.5-0601R MHP1.5-1060L

■ MHP allowable transmission torque table

Reduction ratio	Combination	Unit	Rotational speed of pinion / Allowable torque (Gear side)				
			600rpm	900rpm	1200rpm	1800rpm	3000rpm
15	MHP1-0453R MHP1-3045L	N·m	10.3	9.61	8.82	7.35	3.72
		kgf·m	1.05	0.98	0.9	0.75	0.38
15	MHP1.5-0453R MHP1.5-3045L	N·m	41.2	38.2	35.3	29.4	14.7
		kgf·m	4.2	3.9	3.6	3	1.5
20	MHP1.5-0603R MHP1.5-3060L	N·m	82.4	76.7	69.2	54.9	—
		kgf·m	8.4	7.82	7.06	5.6	—
30	MHP1-0602R MHP1-2060L	N·m	24.1	22.5	20.7	17.3	8.62
		kgf·m	2.46	2.29	2.11	1.76	0.88
45	MHP1-0451R MHP1-1045L	N·m	11.3	10.5	9.61	8.04	4.02
		kgf·m	1.15	1.07	0.98	0.82	0.41
45	MHP1.5-0451R MHP1.5-1045L	N·m	46.6	43.2	39.9	33.2	16.7
		kgf·m	4.75	4.41	4.07	3.39	1.7
60	MHP1-0601R MHP1-1060L	N·m	25.3	23.4	21.7	18	9.02
		kgf·m	2.58	2.39	2.21	1.84	0.92
60	MHP1.5-0601R MHP1.5-1060L	N·m	93.9	87.2	76.3	54.9	—
		kgf·m	9.58	8.89	7.78	5.6	—

The allowable torques in the table are obtained from the results of experimentation lubricated with Kingstar SG-0 (NIHON GREASE).

Spur Gears

Helical Gears

Internal Gears

Racks

CP Racks & Pinions

Miter Gears

Bevel Gears

Screw Gears

Worm Gears

Gearboxes

Other Products



Specifications	
Precision grade	JIS B 1704: 1978 grade 1
Gear teeth	Gleason
Pressure angle	20°
Helix angle	35°
Material	SCM415
Heat treatment	Carburized *
Tooth hardness	55 to 60HRC

* In the illustration, the area surrounded with ---- line is masked during the carburization process (max. HRC40 or so) and can be modified.

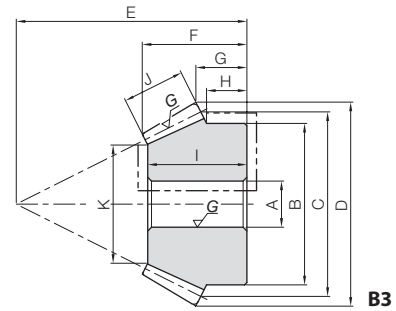

B3

Catalog Number	Gear Ratio	Module	No. of teeth	Direction of spiral	Shape	Bore	Hub dia.	Pitch dia.	Outside dia.	Mounting distance	Total length	Crown to back
						A _{H7}	B	C	D	E	F	G
MBSG2-4020R MBSG2-2040L	2	m2	40	R	B4	15	45	80	81.1	45	31.78	26.1
			20	L	B3	12	35	40	44.1	55	28.16	16.02
MBSG2.5-4020R MBSG2.5-2040L	2	m2.5	40	R	B4	16	55	100	101.29	50	33.35	26.29
			20	L	B3	12	43	50	55.12	65	31.01	16.28
MBSG3-4020R MBSG3-2040L	2	m3	40	R	B4	20	65	120	121.57	60	39.81	31.57
			20	L	B3	16	52	60	66.03	80	38.9	21.51
MBSG4-4020R MBSG4-2040L	2	m4	40	R	B4	25	80	160	162.06	75	48.27	37.06
			20	L	B3	20	70	80	88.46	100	45.38	22.12

Product Precautions → Page 342

■ Mating surface of spiral bevel gears

Spiral bevel gears have convex and concave tooth surfaces. If the direction of rotation of the drive gear differs, the meshing tooth surface will also change. The table on the right shows how to view the convex and concave tooth surfaces and the meshing tooth surface with respect to the direction of rotation of the drive gear.

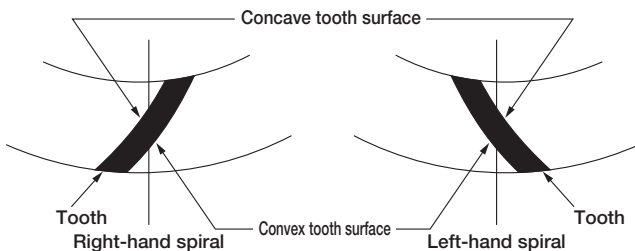

For right-hand drive gear

Direction of rotation of drive gear ^{NOTE 1}	Meshing tooth surface	
	Right-hand drive gear	Left-hand driven gear
Clockwise	Convex tooth surface	Concave tooth surface
Counterclockwise	Concave tooth surface	Convex tooth surface

For left-hand drive gear

Direction of rotation of drive gear ^{NOTE 1}	Meshing tooth surface	
	Left-hand drive gear	Right-hand driven gear
Clockwise	Concave tooth surface	Convex tooth surface
Counterclockwise	Convex tooth surface	Concave tooth surface

[NOTE 1] The direction of rotation in the table is as seen from the hub of the gear.

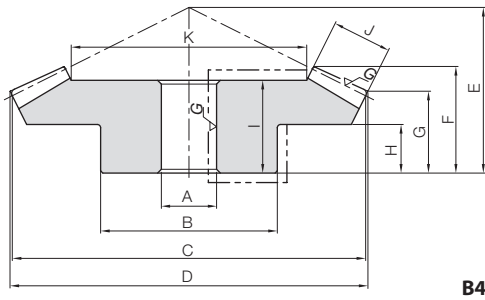

B4

Hub width H	Hole length I	Face width J	Holding surface dia. K	Allowable torque (N·m)		Allowable torque (kgf·m)		Backlash (mm)	Weight (kg)	Catalog Number
				Bending strength	Surface durability	Bending strength	Surface durability			
18 13.75	29 27	14	52.7 25.39	56.5 28.2	94.2 47.1	5.76 2.88	9.61 4.80	0.04~0.10	0.57 0.18	MBSG2-4020R MBSG2-2040L
16 13.25	30 29	17	66.99 29.97	108 54.1	184 91.8	11.0 5.52	18.7 9.37	0.05~0.11	1.01 0.31	MBSG2.5-4020R MBSG2.5-2040L
20 18	35 36.5	20	80.28 36.56	185 92.4	318 159	18.8 9.42	32.4 16.2	0.06~0.12	1.64 0.56	MBSG3-4020R MBSG3-2040L
22 17.5	42 43	27	106.63 51.25	441 221	778 389	45.0 22.5	79.3 39.7	0.09~0.15	3.55 1.20	MBSG4-4020R MBSG4-2040L

■ The force applied to the teeth of the spiral bevel gear

The table below shows, for spiral bevel gears with an axis angle of $\Sigma = 90^\circ$, pressure angle of $\alpha_n = 20^\circ$ and spiral angle of $\beta_m = 35^\circ$, the magnitudes of the axial force F_x and radial force F_r where the tangential force F_t at the center of the tooth width is 100.

Thrust force F_x
Radial force F_r value

(1) Force applied to pinion

Meshing tooth surface	Gear Ratio z_2/z_1						
	1.0	1.5	2.0	2.5	3.0	4.0	5.0
Concave tooth surface	80.9	82.9	82.5	81.5	80.5	78.7	77.4
	-18.1	-1.9	8.4	15.2	20.0	26.1	29.8
Convex tooth surface	-18.1	-33.6	-42.8	-48.5	-52.4	-57.2	-59.9
	80.9	75.8	71.1	67.3	64.3	60.1	57.3

(2) Force applied to gear

Meshing tooth surface	Gear Ratio z_2/z_1						
	1.0	1.5	2.0	2.5	3.0	4.0	5.0
Concave tooth surface	80.9	75.8	71.1	67.3	64.3	60.1	57.3
	-18.1	-33.6	-42.8	-48.5	-52.4	-57.2	-59.9
Convex tooth surface	-18.1	-1.9	8.4	15.2	20.0	26.1	29.8
	80.9	82.9	82.5	81.5	80.5	78.7	77.4



Specifications	
Precision grade	JIS B 1704: 1978 grade 2
Gear teeth	Gleason
Pressure angle	20°
Helix angle	35°
Material	S45C
Heat treatment	Gear teeth induction hardened *
Tooth hardness	50 to 60HRC
Surface treatment	Black oxide coated except for ground part

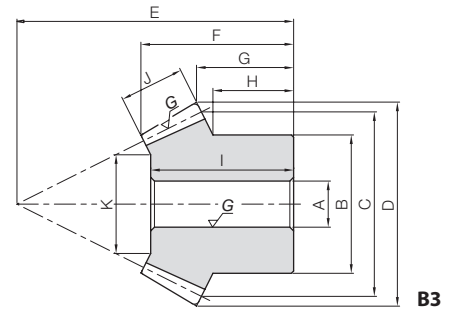

* Due to the gear teeth being induction hardened, no secondary operations can be performed on tooth areas including the bottom land (approx. 2 to 3 mm).

- Spur Gears
- Helical Gears
- Internal Gears
- Racks
- CP Racks & Pinions
- Miter Gears
- Bevel Gears
- Screw Gears
- Worm Gears
- Gearboxes
- Other Products

Catalog Number	Gear Ratio	Module	No. of teeth	Direction of spiral	Shape	Bore	Hub dia.	Pitch dia.	Outside dia.	Mounting distance	Total length	Crown to back
						AH7	B	C	D	E	F	G
SBSG2-3020R SBSG2-2030L	1.5	m2	30	R	B4	12	35	60	61.6	40	26.6	21.2
			20	L	B3	10	30	40	43.55	45	24.91	16.18
m2.5		30	R	B4	15	45	75	77.09	50	33.86	26.56	
		20	L	B3	12	40	50	54.43	55	30.88	18.98	
SBSG3-3020R SBSG3-2030L	1.5	m3	30	R	B4	16	50	90	92.21	55	35.34	26.66
			20	L	B3	16	45	60	65.58	70	40.17	26.86
m4		30	R	B4	20	70	120	122.85	75	47.49	37.14	
		20	L	B3	20	60	80	87.34	90	48.17	32.45	
SBSG2-4020R SBSG2-2040L	2	m2	40	R	B4	12	40	80	80.99	45	32.26	25.99
			20	L	B3	12	32	40	44.1	60	34.04	21.02
m2.5		40	R	B4	15	50	100	101.27	55	39.65	31.27	
		20	L	B3	12	40	50	55.21	75	43.61	26.3	
SBSG3-4020R SBSG3-2040L	2	m3	40	R	B4	20	60	120	121.48	65	45.76	36.48
			20	L	B3	16	50	60	66.06	90	50.63	31.52
m4		40	R	B4	20	70	160	162.07	80	53.69	42.07	
		20	L	B3	20	60	80	88.5	120	66.24	42.12	
SBSG2-4515R SBSG2-1545L	3	m2	45	R	B4	12	40	90	90.67	40	30.29	26.01
			15	L	B3	10	24	30	34.78	60	29.66	15.8
m2.5		45	R	B4	15	50	112.5	113.32	50	38.25	32.47	
		15	L	B3	12	30	37.5	43.36	75	38.27	19.73	
SBSG3-4515R SBSG3-1545L	3	m3	45	R	B4	20	60	135	135.99	55	40.59	33.98
			15	L	B3	15	38	45	52.08	90	44.98	23.68

Product Precautions → Page 342

■ Mating surface of spiral bevel gears

Spiral bevel gears have convex and concave tooth surfaces. If the direction of rotation of the drive gear differs, the meshing tooth surface will also change. The table on the right shows how to view the convex and concave tooth surfaces and the meshing tooth surface with respect to the direction of rotation of the drive gear.

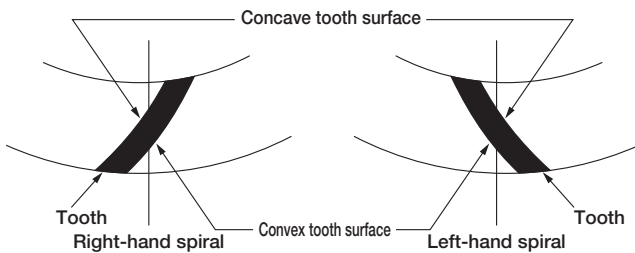

For right-hand drive gear

Direction of rotation of drive gear ^{NOTE 1}	Meshing tooth surface	
	Right-hand drive gear	Left-hand driven gear
Clockwise	Convex tooth surface	Concave tooth surface
Counterclockwise	Concave tooth surface	Convex tooth surface

For left-hand drive gear

Direction of rotation of drive gear ^{NOTE 1}	Meshing tooth surface	
	Left-hand drive gear	Right-hand driven gear
Clockwise	Concave tooth surface	Convex tooth surface
Counterclockwise	Convex tooth surface	Concave tooth surface

[NOTE 1] The direction of rotation in the table is as seen from the hub of the gear.

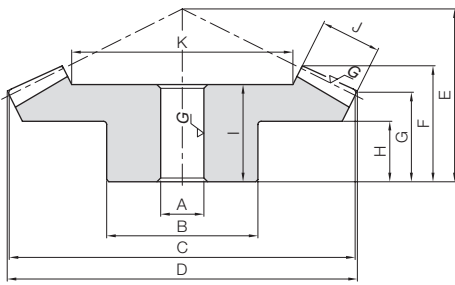

B4

Hub width H	Hole length I	Face width J	Holding surface dia. K	Allowable torque (N·m)		Allowable torque (kgf·m)		Backlash (mm)	Weight (kg)	Catalog Number
				Bending strength	Surface durability	Bending strength	Surface durability			
15 11.67	23 22	11	37.56 21.34	14.1 9.61	14.2 9.44	1.44 0.98	1.44 0.96	0.05~0.11	0.26 0.13	SBSG2-3020R SBSG2-2030L
18 14.17	30 28	15	45.61 27.42	29.0 19.8	29.7 19.8	2.96 2.02	3.03 2.02	0.06~0.12	0.55 0.28	SBSG2.5-3020R SBSG2.5-2030L
17 20	31 37	17	57.14 34.71	48.4 33.1	50.4 33.6	4.94 3.37	5.14 3.42	0.07~0.13	0.82 0.49	SBSG3-3020R SBSG3-2030L
25 23.33	40 43	20	78.59 46.89	106 72.2	113 75.3	10.8 7.36	11.5 7.68	0.10~0.16	1.90 1.05	SBSG4-3020R SBSG4-2030L
18 18	27 32	15	48.46 20.92	25.5 12.8	26.7 13.4	2.60 1.30	2.73 1.36	0.05~0.11	0.51 0.19	SBSG2-4020R SBSG2-2040L
20 22.5	34 40	20	59.28 20.56	51.7 25.9	55.1 27.6	5.27 2.64	5.62 2.81	0.06~0.12	1.06 0.42	SBSG2.5-4020R SBSG2.5-2040L
24 27.5	38 47	22	73.81 29.61	84.8 42.5	91.9 46.0	8.65 4.33	9.38 4.69	0.07~0.13	1.67 0.69	SBSG3-4020R SBSG3-2040L
28 35	45 62	28	102.39 42.78	195 97.9	217 109	19.9 9.98	22.2 11.1	0.10~0.16	3.33 1.53	SBSG4-4020R SBSG4-2040L
17 14	26 29	15	59.04 19.13	34.8 11.2	28.1 9.38	3.55 1.14	2.87 0.96	0.05~0.11	0.60 0.095	SBSG2-4515R SBSG2-1545L
22 17.5	35 37	20	72.84 20.51	59.0 18.9	48.3 16.1	6.01 1.93	4.93 1.64	0.06~0.12	1.21 0.19	SBSG2.5-4515R SBSG2.5-1545L
20 21.33	35 44	23	88.18 28.54	99.3 31.8	82.5 27.5	10.1 3.24	8.41 2.80	0.07~0.13	1.99 0.34	SBSG3-4515R SBSG3-1545L

■ The force applied to the teeth of the spiral bevel gear

The table below shows, for spiral bevel gears with an axis angle of $\Sigma = 90^\circ$, pressure angle of $\alpha_n = 20^\circ$ and spiral angle of $\beta_m = 35^\circ$, the magnitudes of the axial force F_x and radial force F_r where the tangential force F_t at the center of the tooth width is 100.

$$\frac{\text{Thrust force } F_x}{\text{Radial force } F_r} \text{ value}$$

(1) Force applied to pinion

Meshing tooth surface	Gear Ratio z_2/z_1						
	1.0	1.5	2.0	2.5	3.0	4.0	5.0
Concave tooth surface	80.9	82.9	82.5	81.5	80.5	78.7	77.4
	-18.1	-1.9	8.4	15.2	20.0	26.1	29.8
Convex tooth surface	-18.1	-33.6	-42.8	-48.5	-52.4	-57.2	-59.9
	80.9	75.8	71.1	67.3	64.3	60.1	57.3

(2) Force applied to gear

Meshing tooth surface	Gear Ratio z_2/z_1						
	1.0	1.5	2.0	2.5	3.0	4.0	5.0
Concave tooth surface	80.9	75.8	71.1	67.3	64.3	60.1	57.3
	-18.1	-33.6	-42.8	-48.5	-52.4	-57.2	-59.9
Convex tooth surface	-18.1	-1.9	8.4	15.2	20.0	26.1	29.8
	80.9	82.9	82.5	81.5	80.5	78.7	77.4



Finished Bore Spiral Bevel Gears



Specifications	
Precision grade	JIS B 1704: 1978 grade 4
Gear teeth	Gleason
Pressure angle	20°
Helix angle	35°
Material	SCM415
Heat treatment	Carburized *
Tooth hardness	55 to 60HRC

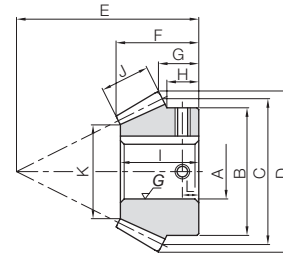

BK

* No secondary operations can be performed on these finished gears due to the applied carburizing process.

Catalog Number	Gear Ratio	Module	No. of teeth	Direction of spiral	Shape	Bore		Pitch dia.	Outside dia.	Mounting distance	Total length	Crown to back	Hub width	Hole length
						A _{H7}	B							
MBSA2-3020R MBSB2-3020R	1.5	m2	30	R	B4	20	40	60	61.36	40	26.8	21.02	14	23
22														
MBSA2-2030L MBSB2-2030L		m2	20	L	BK	15	35	40	43.49	45	24.96	16.16	13.33	23
18														
MBSA2.5-3020R MBSB2.5-3020R		m2.5	30	R	B4	22	48	75	76.74	50	33.6	26.31	18	30
25														
MBSA2.5-2030L MBSB2.5-2030L		m2.5	20	L	BK	18	43	50	54.43	55	30.08	18.98	15.17	28
20														
MBSA3-3020R MBSB3-3020R		m3	30	R	B4	25	60	90	92.21	60	40.34	31.66	21	36
30														
MBSA3-2030L MBSB3-2030L		m3	20	L	BK	22	53	60	65.58	65	35.17	21.86	17.67	32.5
25														
MBSA4-3020R MBSB4-3020R		m4	30	R	B4	35	75	120	122.91	70	43.99	32.18	21	39
40														
MBSA4-2030L MBSB4-2030L		m4	20	L	BK	30	70	80	87.34	85	45.53	27.45	21.67	42
35														
MBSA5-3020R MBSA5-2030L MBSB5-2030L	m5	30	R	B7	80	—	150	—	70	35.53	23.8	—	31	
40														
MBSA6-3020R MBSA6-2030L MBSB6-2030L	m6	30	R	B7	90	—	180	—	80	38.86	24.37	—	33	
40														
MBSA6-2030L MBSB6-2030L	m6	20	L	BK	45	105	120	130.48	125	65.57	38.49	30	60	
50														
MBSA2-4020R MBSB2-4020R	2	m2	40	R	B4	20	45	80	81.06	45	31.83	26.06	18	29
22														
MBSA2-2040L MBSB2-2040L		m2	20	L	BK	15	35	40	44.2	55	28.16	16.05	13.75	27
18														
MBSA2.5-4020R MBSB2.5-4020R		m2.5	40	R	B4	25	55	100	101.29	50	33.35	26.29	16	30
28														
MBSA2.5-2040L MBSB2.5-2040L		m2.5	20	L	BK	20	43	50	55.12	65	31.01	16.28	13.25	29
22														
MBSA3-4020R MBSB3-4020R		m3	40	R	B4	30	65	120	121.57	60	39.81	31.57	21	35
35														
MBSA3-2040L MBSB3-2040L		m3	20	L	BK	22	53	60	66.03	80	38.9	21.51	18.25	36.5
25														
MBSA4-4020R MBSA4-2040L MBSB4-2040L		m4	40	R	B7	80	—	160	—	60	32.08	22.53	—	28
35														
MBSA5-4020R MBSA5-2040L MBSB5-2040L		m5	40	R	B7	90	—	200	—	70	35.2	22.98	—	30
45														
MBSA6-4020R MBSA6-2040L MBSB6-2040L	m6	40	R	B7	110	—	240	—	80	37.89	23.62	—	32	
55														
MBSA6-2040L MBSB6-2040L	m6	20	L	BK	50	105	120	132.04	150	67.8	33.01	26.25	64	
55														

[Caution on Product Characteristics] ① The keyway tolerance is the value before hardening.



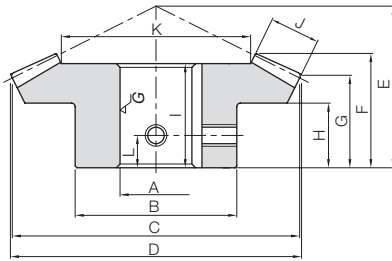

B4

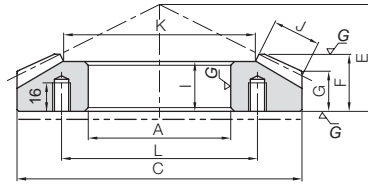

B7

Face width	Holding surface dia.	Keyway	Socket head screw		Allowable torque (N·m)		Allowable torque (kgf·m)		Backlash (mm)	Weight (kg)	Catalog Number
			Size	L	Bending strength	Surface durability	Bending strength	Surface durability			
J	K	Width x Depth									
11	37.56	6 x 2.8 6 x 2.8	2-M5 2-M5	7	34.4	38.4	3.51	3.91	0.06~0.16	0.26 0.24	MBSA2-3020R MBSB2-3020R
11	24.34	5 x 2.3 6 x 2.8	2-M4 2-M5	6.5	23.5	25.6	2.39	2.61		0.14 0.13	MBSA2-2030L MBSB2-2030L
14	48.01	6 x 2.8 8 x 3.3	2-M5 2-M6	9	68.0	76.8	6.93	7.84	0.07~0.17	0.52 0.49	MBSA2.5-3020R MBSB2.5-3020R
14	31.02	6 x 2.8 6 x 2.8	2-M5 2-M5	7.5	46.4	51.2	4.73	5.22		0.26 0.25	MBSA2.5-2030L MBSB2.5-2030L
17	57.14	8 x 3.3 8 x 3.3	2-M6 2-M6	11	118	135	12.1	13.8	0.08~0.18	0.96 0.90	MBSA3-3020R MBSB3-3020R
17	36.2	6 x 2.8 8 x 3.3	2-M5 2-M6	9	80.7	90.1	8.23	9.19		0.46 0.43	MBSA3-2030L MBSB3-2030L
23	76.72	10 x 3.3 12 x 3.3	2-M8 2-M8	10	283	328	28.9	33.5	0.12~0.27	1.77 1.68	MBSA4-3020R MBSB4-3020R
23	48.07	8 x 3.3 10 x 3.3	2-M6 2-M8	11	193	219	19.7	22.3		1.03 0.95	MBSA4-2030L MBSB4-2030L
28	97.36	—	6-M10	110	544	637	55.4	64.9	0.14~0.34	2.80	MBSA5-3020R
28	62.04	10 x 3.3 12 x 3.3	2-M8 2-M8	13	371	425	37.8	43.3		2.01 1.89	MBSA5-2030L MBSB5-2030L
34	115.61	—	6-M10	120	927	1120	94.6	114	0.16~0.36	4.55	MBSA6-3020R
34	72.41	14 x 3.8 14 x 3.8	2-M10 2-M10	15	633	745	64.5	76.0		3.56 3.38	MBSA6-2030L MBSB6-2030L
14	52.7	6 x 2.8 6 x 2.8	2-M5 2-M5	9	59.6	69.6	6.08	7.09	0.06~0.16	0.53 0.51	MBSA2-4020R MBSB2-4020R
14	25.39	5 x 2.3 6 x 2.8	2-M4 2-M5	7	29.9	34.8	3.05	3.55		0.16 0.14	MBSA2-2040L MBSB2-2040L
17	66.99	8 x 3.3 8 x 3.3	2-M6 2-M6	8	114	135	11.7	13.8	0.07~0.17	0.93 0.90	MBSA2.5-4020R MBSB2.5-4020R
17	29.97	6 x 2.8 6 x 2.8	2-M5 2-M5	7	57.3	67.6	5.84	6.89		0.26 0.25	MBSA2.5-2040L MBSB2.5-2040L
20	80.28	8 x 3.3 10 x 3.3	2-M6 2-M8	11	195	233	19.9	23.7	0.08~0.18	1.47 1.40	MBSA3-4020R MBSB3-4020R
20	36.56	6 x 2.8 8 x 3.3	2-M5 2-M6	9.5	97.7	116	9.97	11.9		0.51 0.48	MBSA3-2040L MBSB3-2040L
27	107.63	—	6-M10	110	466	564	47.5	57.5	0.12~0.27	3.11	MBSA4-4020R
27	51.25	8 x 3.3 10 x 3.3	2-M6 2-M8	9	234	282	23.8	28.8		1.05 0.96	MBSA4-2040L MBSB4-2040L
34	133.97	—	6-M10	120	915	1120	93.3	114	0.14~0.34	5.59	MBSA5-4020R
34	61.95	12 x 3.3 14 x 3.8	2-M8 2-M10	11	458	559	46.7	57.0		1.96 1.82	MBSA5-2040L MBSB5-2040L
40	162.56	—	6-M10	140	1530	1920	156	196	0.16~0.36	8.48	MBSA6-4020R
40	77.11	14 x 3.8 16 x 4.3	2-M10 2-M10	14	766	961	78.1	97.9		3.33 3.11	MBSA6-2040L MBSB6-2040L

When installing products produced in B7 style (ring type), always secure the gears onto the mounting base with taper pins to absorb the rotational loads. It is dangerous to secure with bolts only.

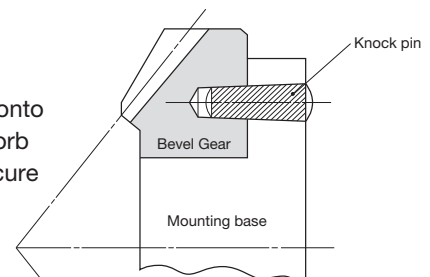



Finished Bore Spiral Bevel Gears



Specifications	
Precision grade	JIS B 1704: 1978 grade 4
Gear teeth	Gleason
Pressure angle	20°
Helix angle	35°
Material	SCM415
Heat treatment	Carburized *
Tooth hardness	55 to 60HRC

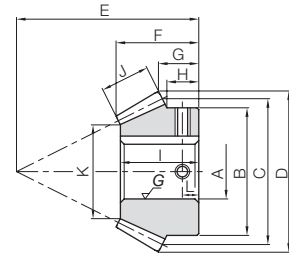

BK

* No secondary operations can be performed on these finished gears due to the applied carburizing process.

Catalog Number	Gear Ratio	Module	No. of teeth	Direction of spiral	Shape	Bore		Pitch dia.	Outside dia.	Mounting distance	Total length	Crown to back	Hub width	Hole length
						A _{H7}	B							
MBSA2-4515R MBSB2-4515R	3	m2	45	R	B4	20 22	48	90	90.66	40	30.01	25.99	18	27
MBSA2-1545L MBSB2-1545L		m2	15	L	BT BK	10 12	26	30	34.59	55	23.78	10.77	9.33	22.5
MBSA2.5-4515R MBSB2.5-4515R		m2.5	45	R	B4	22 25	55	112.5	113.28	45	32.43	27.42	18	28
MBSA2.5-1545L MBSB2.5-1545L		m2.5	15	L	BK	12 15	32	37.5	43.06	70	30.51	14.68	12.84	29
MBSA3-4515R MBSB3-4515R		m3	45	R	B4	30 32	65	135	136.03	55	39.94	34.05	22	35
MBSA3-1545L MBSB3-1545L		m3	15	L	BK	18 20	38	45	52	85	38.12	18.67	16.33	36.5
MBSA4-4515R MBSA4-1545L MBSB4-1545L		m4	45	R	B7	80	—	180	—	50	28.85	22.14	—	25
		m4	15	L	BK	22 25	52	60	69.24	110	47.51	21.54	18.67	45.5
MBSA5-4515R MBSA5-1545L MBSB5-1545L		m5	45	R	B7	90	—	225	—	60	33.57	25.16	—	28
		m5	15	L	BK	28 32	65	75	86.55	135	56.89	24.43	20.83	54
MBSA6-4515R MBSA6-1545L MBSB6-1545L		m6	45	R	B7	110	—	270	—	70	38.28	28.05	—	32
		m6	15	L	BK	35 40	78	90	103.13	160	66.39	27.19	23	63

[Caution on Product Characteristics] ① The keyway tolerance is the value before hardening.

- Spur Gears
- Helical Gears
- Internal Gears
- Racks
- CP Racks & Pinions
- Miter Gears
- Bevel Gears
- Screw Gears
- Worm Gears
- Gearboxes
- Other Products



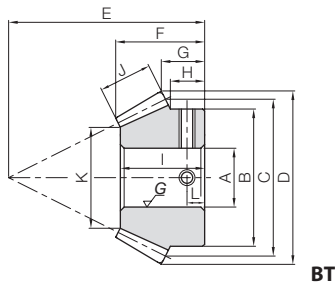

BT

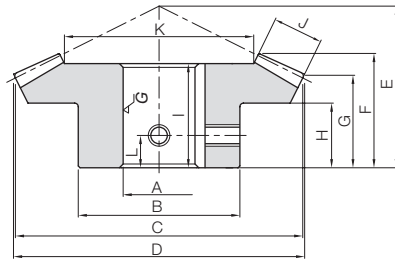

B4

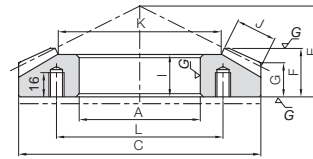

B7

Face width	Holding surface dia.	Keyway	Socket head screw		Allowable torque (N·m)		Allowable torque (kgf·m)		Backlash (mm)	Weight (kg)	Catalog Number
			Size	L	Bending strength	Surface durability	Bending strength	Surface durability			
J	K	Width x Depth									
14	61.82	6 x 2.8 6 x 2.8	2-M5 2-M5	9	67.8	61.3	6.91	6.25	0.06~0.16	0.61 0.60	MBSA2-4515R MBSB2-4515R
14	16.46	— 4 x 1.8	2-M4 2-M4	5	21.7	20.4	2.22	2.08		0.081 0.073	MBSA2-1545L MBSB2-1545L
17	77.83	6 x 2.8 8 x 3.3	2-M5 2-M6	9	130	119	13.3	12.1	0.07~0.17	1.01 0.98	MBSA2.5-4515R MBSB2.5-4515R
17	21.48	4 x 1.8 5 x 2.3	2-M4 2-M4	7	41.6	39.6	4.24	4.04		0.16 0.15	MBSA2.5-1545L MBSB2.5-1545L
21	92.39	8 x 3.3 10 x 3.3	2-M6 2-M8	11	229	211	23.3	21.6	0.08~0.18	1.78 1.75	MBSA3-4515R MBSB3-4515R
21	26.18	6 x 2.8 6 x 2.8	2-M5 2-M5	9	73.3	70.5	7.48	7.18		0.26 0.24	MBSA3-1545L MBSB3-1545L
28	124.3	—	6-M10	110	542	508	55.3	51.8	0.12~0.27	3.93	MBSA4-4515R
28	35.91	6 x 2.8 8 x 3.3	2-M5 2-M6	10	174	169	17.7	17.3		0.63 0.58	MBSA4-1545L MBSB4-1545L
35	154.88	—	6-M10	120	1060	1000	108	102	0.14~0.34	7.38	MBSA5-4515R
35	42.64	8 x 3.3 10 x 3.3	2-M6 2-M8	11	339	334	34.6	34.1		1.16 1.07	MBSA5-1545L MBSB5-1545L
42	186.12	—	6-M10	140	1790	1740	183	178	0.16~0.36	12.0	MBSA6-4515R
42	52.37	10 x 3.3 12 x 3.3	2-M8 2-M8	12	575	581	58.6	59.3		1.90 1.75	MBSA6-1545L MBSB6-1545L

Spur Gears

Helical Gears

Internal Gears

Racks

CP Racks & Pinions

Miter Gears

Bevel Gears

Screw Gears

Worm Gears

Gearboxes

Other Products

When installing products produced in B7 style (ring type), always secure the gears onto the mounting base with taper pins to absorb the rotational loads. It is dangerous to secure with bolts only.

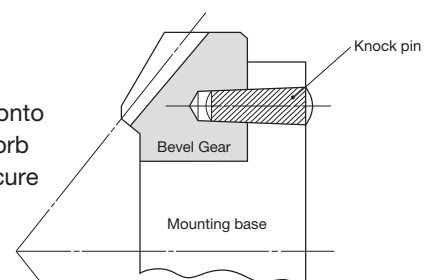



Specifications	
Precision grade	JIS B 1704: 1978 grade 4
Gear teeth	Gleason
Pressure angle	20°
Helix angle	35°
Material	S45C
Heat treatment	Gear teeth induction hardened *
Tooth hardness	50 to 60HRC
Surface treatment	Black oxide coating

* Due to the gear teeth being induction hardened, no secondary operations can be performed on tooth areas including the bottom land (approx. 2 to 3 mm).

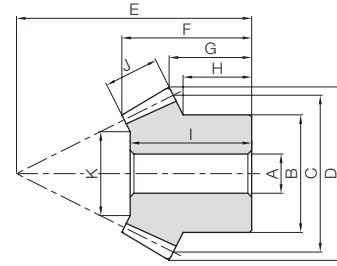

B3

Catalog Number	Gear Ratio	Module	No. of teeth	Direction of spiral	Shape	Bore		Hub dia.	Pitch dia.	Outside dia.	Mounting distance	Total length	
						A	B					C	D
SBS2-3020R SBS2-2030L	1.5	m2	30	R	B4	12	35	60	61.36	40	26.8	21.02	
20			L	B3	10	30	40	43.49	45	24.96	16.16		
SBS2.5-3020R SBS2.5-2030L		m2.5	30	R	B4	15	45	75	77.09	50	33.86	26.56	
20			L	B3	12	40	50	54.43	55	30.88	18.98		
SBS3-3020R SBS3-2030L		m3	30	R	B4	16	50	90	92.21	55	35.34	26.66	
20			L	B3	16	45	60	65.58	70	40.17	26.86		
SBS4-3020R SBS4-2030L		m4	30	R	B4	20	70	120	122.85	75	47.49	37.14	
20			L	B3	20	60	80	87.34	90	48.17	32.45		
SBS5-3020R SBS5-2030L		m5	30	R	B4	25	90	150	153.67	90	58.08	42.75	
20			L	B3	22	80	100	109.2	110	61.62	38.07		
SBS1-4020R SBS1-2040L	2	m1	40	R	B4	8	25	40	40.52	22	15.02	12.52	
20			L	B3	6	16	20	22.08	28	13.73	8.52		
SBS1.5-4020R SBS1.5-2040L		m1.5	40	R	B4	10	38	60	60.75	35	24.93	20.75	
20			L	B3	8	25	30	33.08	46	25.45	16.77		
SBS2-4020R SBS2-2040L		m2	40	R	B4	12	40	80	81	45	32.27	26	
20			L	B3	12	32	40	44.1	60	34.04	21.02		
SBS2.5-4020R SBS2.5-2040L		m2.5	40	R	B4	15	50	100	101.27	55	39.65	31.27	
20			L	B3	12	40	50	55.2	75	43.61	26.3		
SBS3-4020R SBS3-2040L		m3	40	R	B4	20	60	120	121.48	65	45.76	36.47	
20			L	B3	16	50	60	66.07	90	50.63	31.52		
SBS4-4020R SBS4-2040L	m4	40	R	B4	20	70	160	162.07	80	53.69	42.07		
20		L	B3	20	60	80	88.5	120	66.24	42.12			
SBS5-4020R SBS5-2040L	m5	40	R	B5	25	100	200	202.54	90	55.02	42.54		
20		L	B3	22	80	100	110.45	140	68.48	42.61			
SBS3-3618R SBS3-1836L	2	m3	36	R	B4	20	60	108	109.53	52	34.82	26.53	
18			L	B3	16	46	54	60.28	75	39.78	22.57		
SBS4-3618R SBS4-1836L	m4	36	R	B4	20	70	144	145.99	72	48.84	37.99		
18		L	B3	20	60	72	80.19	100	52.51	30.05			
SBS2-4518R SBS2-1845L	2.5	m2	45	R	B4	12	48	90	90.79	40	27.67	22.98	
18			L	B3	10	32	36	40.42	60	28.54	15.88		
SBS2.5-4518R SBS2.5-1845L		m2.5	45	R	B4	15	55	112.5	113.49	50	34.94	28.74	
18			L	B3	12	40	45	50.35	72	33.19	16.82		
SBS3-4518R SBS3-1845L		m3	45	R	B4	20	65	135	136.24	60	41.65	34.55	
18			L	B3	16	48	54	60.69	85	37.82	18.84		
SBS4-4518R SBS4-1845L		m4	45	R	B4	25	80	180	181.57	75	50.98	40.96	
18			L	B3	20	62	72	80.86	110	48.03	21.77		
SBS5-4518R SBS5-1845L		m5	45	R	B4	30	100	225	225.81	90	57.9	46.01	
18			L	B3	22	80	90	103.87	135	56.02	25.27		

[Caution on Product Characteristics] ① The bore may slightly vary due to the effect of heat treatment. When using with the listed bore diameter, you may need to ream the bore prior to use.



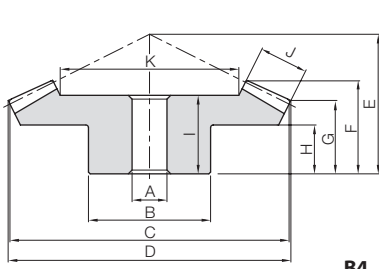

B4

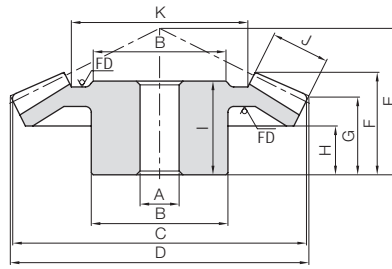

B5

* FD has a forged finish surface.

Hub width H	Hole length I	Face width J	Holding surface dia. K	Allowable torque (N-m)		Allowable torque (kgf-m)		Backlash (mm)	Weight (kg)	Catalog Number
				Bending strength	Surface durability	Bending strength	Surface durability			
15 11.67	23 22	11	37.56 21.34	15.4 10.5	11.3 7.52	1.57 1.07	1.15 0.77	0.06~0.16	0.26 0.13	SBS2-3020R SBS2-2030L
18 14.17	30 28	15	45.61 27.42	31.7 21.6	23.6 15.7	3.23 2.20	2.40 1.60	0.07~0.17	0.55 0.28	SBS2.5-3020R SBS2.5-2030L
17 20	31 37	17	57.14 34.71	52.9 36.1	39.7 26.5	5.39 3.68	4.05 2.70	0.08~0.18	0.82 0.49	SBS3-3020R SBS3-2030L
25 23.33	40 43	20	78.59 46.89	115 78.7	88.1 58.8	11.8 8.03	8.99 5.99	0.12~0.27	1.90 1.05	SBS4-3020R SBS4-2030L
24 28.33	50 56	30	91.22 54.83	253 173	195 130	25.8 17.6	19.9 13.3	0.14~0.34	4.11 2.29	SBS5-3020R SBS5-2030L
8 7	12 12	6	26.58 9.17	3.01 1.51	2.22 1.11	0.31 0.15	0.23 0.11	0.03~0.13	0.068 0.019	SBS1-4020R SBS1-2040L
15 14.75	22 24	10	39.64 17.28	10.9 5.46	8.22 4.11	1.11 0.56	0.84 0.42	0.05~0.15	0.27 0.088	SBS1.5-4020R SBS1.5-2040L
18 18	27 32	15	48.46 20.92	27.8 13.9	21.3 10.7	2.83 1.42	2.17 1.09	0.06~0.16	0.51 0.19	SBS2-4020R SBS2-2040L
20 22.5	34 40	20	59.28 20.56	56.4 28.2	43.7 21.9	5.75 2.88	4.46 2.23	0.07~0.17	1.06 0.40	SBS2.5-4020R SBS2.5-2040L
24 27.5	38 47	22	73.81 29.61	92.5 46.4	72.6 36.3	9.44 4.73	7.40 3.70	0.08~0.18	1.67 0.69	SBS3-4020R SBS3-2040L
28 35	45 62	28	102.39 42.78	213 107	170 84.8	21.7 10.9	17.3 8.65	0.12~0.27	3.33 1.46	SBS4-4020R SBS4-2040L
26 35	50 63	30	138.92 57.84	376 188	302 151	38.3 19.2	30.8 15.4	0.14~0.34	5.67 2.61	SBS5-4020R SBS5-2040L
17 19	30 37	20	68.27 28.56	74.0 37.0	52.4 26.2	7.54 3.78	5.35 2.67	0.08~0.18	1.15 0.44	SBS3-3618R SBS3-1836L
25 25	42 49	26	91.87 39.72	173 86.4	124 62.1	17.6 8.81	12.7 6.33	0.12~0.27	2.65 1.03	SBS4-3618R SBS4-1836L
15 14.2	25 27.5	14	62.24 23.11	31.0 12.2	21.9 8.74	3.16 1.24	2.23 0.89	0.06~0.16	0.65 0.15	SBS2-4518R SBS2-1845L
18 14.75	31 31.5	18	76.53 26.82	61.6 24.2	44.0 17.6	6.28 2.47	4.49 1.80	0.07~0.17	1.23 0.28	SBS2.5-4518R SBS2.5-1845L
22 16.3	37 36	21	92.96 33.41	104 41.0	75.4 30.2	10.7 4.18	7.69 3.07	0.08~0.18	2.05 0.45	SBS3-4518R SBS3-1845L
24 18	45 46	29	122.33 45.83	253 99.5	185 74.1	25.8 10.2	18.9 7.56	0.12~0.27	4.62 1.00	SBS4-4518R SBS4-1845L
28 20.5	51 52.5	34	156.56 56.9	474 186	350 140	48.4 19.0	35.7 14.3	0.14~0.34	8.11 1.94	SBS5-4518R SBS5-1845L

Spur Gears

Helical Gears

Internal Gears

Racks

CP Racks & Pinions

Miter Gears

Bevel Gears

Screw Gears

Worm Gears

Gearboxes

Other Products



Specifications	
Precision grade	JIS B 1704: 1978 grade 4
Gear teeth	Gleason
Pressure angle	20°
Helix angle	35°*
Material	S45C
Heat treatment	Gear teeth induction hardened **
Tooth hardness	50 to 60HRC
Surface treatment	Black oxide coating

* 6015R and 1560L of SBS1.5 and 2 are 39°.
 ** Due to the gear teeth being induction hardened, no secondary operations can be performed on tooth areas including the bottom land (approx. 2 to 3 mm).

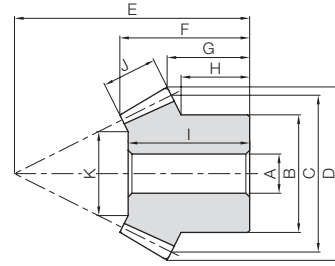

B3

Catalog Number	Gear Ratio	Module	No. of teeth	Direction of spiral	Shape	Bore		Hub dia.	Pitch dia.	Outside dia.	Mounting distance	Total length	
						A	B					F	G
SBS2-4515R SBS2-1545L	3	m2	45	R	B4	12	40	90	90.67	40	30.29	26.01	
15			L	B3	10	24	30	34.78	60	29.66	15.8		
SBS2.5-4515R SBS2.5-1545L		m2.5	45	R	B4	15	50	112.5	113.32	50	38.25	32.47	
15			L	B3	12	30	37.5	43.36	75	38.27	19.73		
SBS3-4515R SBS3-1545L		m3	45	R	B4	20	60	135	135.99	55	40.59	33.98	
15			L	B3	15	38	45	52.08	90	44.98	23.68		
SBS4-4515R SBS4-1545L		m4	45	R	B5	20	80	180	181.3	70	50.62	41.95	
15			L	B3	16	50	60	69.3	115	54.37	26.55		
SBS5-4515R SBS5-1545L		m5	45	R	B5	30	90	225	226.61	75	50.05	39.92	
15			L	B3	20	60	75	86.55	145	66.89	34.43		
SBS1.5-6015R SBS1.5-1560L	4	m1.5	60	R	B4	12	60	90	90.36	32	24.08	21.48	
15			L	B3	8	18	22.5	26.09	56	22.95	11.45		
SBS2-6015R SBS2-1560L		m2	60	R	B4	15	80	120	120.46	42	31.5	27.91	
15			L	B3	10	24	30	34.68	75	30.94	15.58		
SBS2.5-6015R SBS2.5-1560L		m2.5	60	R	B4	20	100	150	150.5	53	39.68	35.24	
15			L	B3	12	30	37.5	44.16	94	38.9	19.83		
SBS3-6015R SBS3-1560L		m3	60	R	B4	20	120	180	180.57	64	47.61	42.64	
15			L	B3	15	38	45	52.64	112	44.01	22.96		

[Caution on Product Characteristics] ① The bore may slightly vary due to the effect of heat treatment. When using with the listed bore diameter, you may need to ream the bore prior to use.

Product Precautions → Page 342

Mating surface of spiral bevel gears

Spiral bevel gears have convex and concave tooth surfaces. If the direction of rotation of the drive gear differs, the meshing tooth surface will also change. The table on the right shows how to view the convex and concave tooth surfaces and the meshing tooth surface with respect to the direction of rotation of the drive gear.

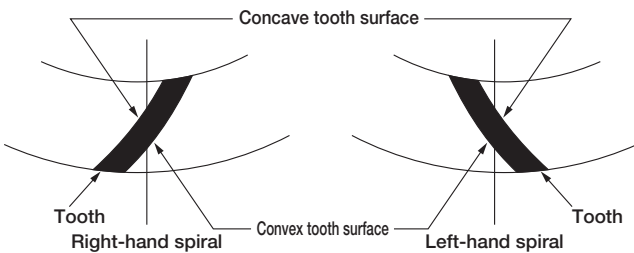

For right-hand drive gear

Direction of rotation of drive gear NOTE 1	Meshing tooth surface	
	Right-hand drive gear	Left-hand driven gear
Clockwise	Convex tooth surface	Concave tooth surface
Counterclockwise	Concave tooth surface	Convex tooth surface

For left-hand drive gear

Direction of rotation of drive gear NOTE 1	Meshing tooth surface	
	Left-hand drive gear	Right-hand driven gear
Clockwise	Concave tooth surface	Convex tooth surface
Counterclockwise	Convex tooth surface	Concave tooth surface

[NOTE 1] The direction of rotation in the table is as seen from the hub of the gear.

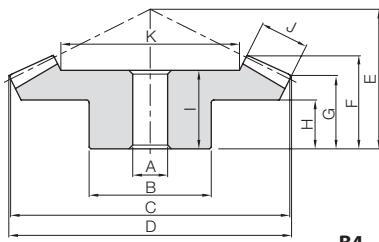

B4

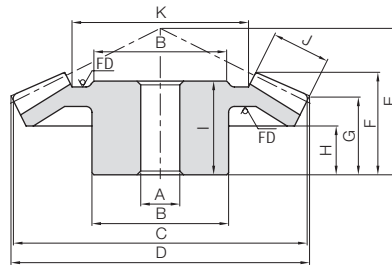

B5

* FD has a forged finish surface.

Hub width H	Hole length I	Face width J	Holding surface dia. K	Allowable torque (N·m)		Allowable torque (kgf·m)		Backlash (mm)	Weight (kg)	Catalog Number
				Bending strength	Surface durability	Bending strength	Surface durability			
17 14	26 29	15	59.04 19.13	31.7 10.1	18.8 6.27	3.23 1.03	1.92 0.64	0.06~0.16	0.60 0.095	SBS2-4515R SBS2-1545L
22 17.5	35 37	20	72.82 20.51	64.3 20.6	38.7 12.9	6.56 2.10	3.94 1.31	0.07~0.17	1.21 0.19	SBS2.5-4515R SBS2.5-1545L
20 21.33	35 44	23	88.18 28.54	108 34.7	65.8 21.9	11.1 3.54	6.71 2.24	0.08~0.18	1.99 0.34	SBS3-4515R SBS3-1545L
24 23.33	45 52	30	118.08 32.26	253 81.1	156 52.0	25.8 8.27	15.9 5.30	0.12~0.27	4.04 0.76	SBS4-4515R SBS4-1545L
20 30	44 65	35	152.88 48.64	473 152	295 98.2	48.3 15.5	30.0 10.0	0.14~0.34	6.08 1.44	SBS5-4515R SBS5-1545L
12 10.43	21 22.5	12	65.39 15.55	17.9 4.22	12.9 3.21	1.83 0.43	1.31 0.33	0.05~0.15	0.70 0.042	SBS1.5-6015R SBS1.5-1560L
16 14.25	27 30	16	87.02 18.06	42.5 10.0	30.9 7.73	4.33 1.02	3.15 0.79	0.06~0.16	1.59 0.10	SBS2-6015R SBS2-1560L
20 18.06	34 37.5	20	108.64 20.58	96.1 22.6	58.4 14.6	9.79 2.31	5.95 1.49	0.07~0.17	3.13 0.20	SBS2.5-6015R SBS2.5-1560L
25 21.12	41 43	22	134.4 31.58	156 36.8	95.7 23.9	15.9 3.75	9.76 2.44	0.08~0.18	5.38 0.35	SBS3-6015R SBS3-1560L

Spur Gears

Helical Gears

Internal Gears

Racks

CP Racks & Pinions

Miter Gears

Bevel Gears

Screw Gears

Worm Gears

Gearboxes

Other Products

■ The force applied to the teeth of the spiral bevel gear

The table below shows, for spiral bevel gears with an axis angle of $\Sigma = 90^\circ$, pressure angle of $\alpha_n = 20^\circ$ and spiral angle of $\beta_m = 35^\circ$, the magnitudes of the axial force F_x and radial force F_r where the tangential force F_t at the center of the tooth width is 100.

Thrust force F_x
Radial force F_r value

(1) Force applied to pinion

Meshing tooth surface	Gear Ratio z_2/z_1						
	1.0	1.5	2.0	2.5	3.0	4.0	5.0
Concave tooth surface	80.9 -18.1	82.9 -1.9	82.5 8.4	81.5 15.2	80.5 20.0	78.7 26.1	77.4 29.8
Convex tooth surface	-18.1 80.9	-33.6 75.8	-42.8 71.1	-48.5 67.3	-52.4 64.3	-57.2 60.1	-59.9 57.3

(2) Force applied to gear

Meshing tooth surface	Gear Ratio z_2/z_1						
	1.0	1.5	2.0	2.5	3.0	4.0	5.0
Concave tooth surface	80.9 -18.1	75.8 -33.6	71.1 -42.8	67.3 -48.5	64.3 -52.4	60.1 -57.2	57.3 -59.9
Convex tooth surface	-18.1 80.9	-1.9 82.9	8.4 82.5	15.2 81.5	20.0 80.5	26.1 78.7	29.8 77.4



Specifications	
Precision grade	JIS B 1704: 1978 grade 3
Gear teeth	Gleason
Pressure angle	20°
Material	S45C
Heat treatment	—
Tooth hardness	(less than 194HB)
Surface treatment	Black oxide coating

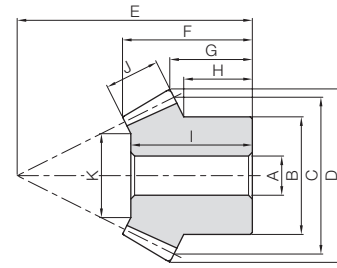

B3

H To order Hardened Plus, please specify **Catalog No. + H**. Example: **SB1.5-3020H**

Catalog Number	Gear Ratio	Module	No. of teeth	Shape	Bore	Hub dia.	Pitch dia.	Outside dia.	Mounting distance	Total length	Crown to back	Hub width	
					A _{H7}	B	C	D	E	F	G	H	
SB1.5-3020	1.5	m1.5	30	B4	10	30	45	46.24	28	18.53	13.93	8	
SB1.5-2030			20	B3	8	25	30	33.13	33	18.63	11.54	8.83	
SB2-3020		m2	30	B4	10	35	60	61.65	40	26.87	21.24	15	
SB2-2030			20	B3	10	30	40	44.18	45	25.06	16.39	11.67	
SB2.5-3020		m2.5	30	B4	15	45	75	77.07	50	34.22	26.55	18	
SB2.5-2030			20	B3	12	35	50	55.22	55	31.06	19.24	12.5	
SB3-3020		m3	30	B4	15	50	90	92.48	55	35.56	26.86	17	
SB3-2030			20	B3	15	45	60	66.27	70	40.48	27.09	20	
SB4-3020		m4	30	B4	20	70	120	123.3	75	47.71	37.48	25	
SB4-2030			20	B3	15	60	80	88.32	90	48.53	32.77	23.33	
SB5-3020		m5	30	B4	25	90	150	154.13	90	58.45	43.1	24	
SB5-2030			20	B3	20	80	100	110.45	110	62.11	38.48	28.33	
SB1.5-3015		2	m1.5	30	B4	8	25	45	45.88	25	17.85	14.63	9
SB1.5-1530				15	B3	6	16	22.5	26.11	32	17.23	10.4	7.88
SB2-3015	m2		30	B4	10	30	60	61.17	31	21.6	17.17	10	
SB2-1530			15	B3	8	22	30	34.81	40	20.59	11.2	8	
SB2.5-3015	m2.5		30	B4	15	40	75	76.46	40	28.75	22.71	15	
SB2.5-1530			15	B3	12	30	37.5	43.51	55	31.81	19	15.63	
SB3-3015	m3		30	B4	16	50	90	91.76	50	37.31	29.26	18	
SB3-1530			15	B3	12	35	45	52.22	70	43.88	26.8	22.5	
SB4-3015	m4		30	B4	20	60	120	122.34	60	42.4	32.34	20	
SB4-1530			15	B3	16	50	60	69.62	85	48.74	27.41	22.5	
SB5-3015	m5		30	B5	20	70	150	152.93	75	52.5	40.43	25	
SB5-1530			15	B3	20	60	75	87.03	110	63.61	38.01	31.25	
SB6-3015	m6		30	B5	25	80	180	183.5	90	62.56	48.49	28	
SB6-1530			15	B3	25	70	90	104.44	125	68.48	38.6	30	
SB2.5-3618	2	m2.5	36	B4	15	55	90	91.46	43	28.52	21.96	13	
SB2.5-1836			18	B3	12	38	45	51.01	64	34.27	20.5	17.25	
SB3-3618		m3	36	B4	20	60	108	109.76	52	34.95	26.76	17	
SB3-1836			18	B3	16	46	54	61.22	75	40.01	22.8	19	
SB4-3618		m4	36	B4	20	70	144	146.34	72	49	38.34	25	
SB4-1836			18	B3	20	60	72	81.62	100	52.77	30.41	25	
SB1-4020	2	m1	40	B4	8	25	40	40.59	22	15.07	12.59	8	
SB1-2040			20	B3	6	16	20	22.41	28	13.78	8.6	7	
SB1.25-4020		m1.25	40	B4	10	32	50	50.73	27	18.54	15.23	10	
SB1.25-2040			20	B3	8	22	25	28.01	36	18.66	11.75	10.25	
SB1.5-4020		m1.5	40	B4	10	38	60	60.88	35	25.01	20.88	15	
SB1.5-2040			20	B3	8	25	30	33.61	46	25.54	16.9	14.75	
SB2-4020		m2	40	B4	12	40	80	81.17	45	32.37	26.17	18	
SB2-2040			20	B3	12	32	40	44.81	60	34.16	21.2	18	
SB2.5-4020		m2.5	40	B4	15	50	100	101.46	55	39.73	31.46	20	
SB2.5-2040			20	B3	12	40	50	56.01	75	43.78	26.5	22.5	
SB3-4020		m3	40	B4	20	60	120	121.76	65	45.85	36.76	24	
SB3-2040			20	B3	16	50	60	67.22	90	50.81	31.8	27.5	
SB4-4020		m4	40	B4	20	70	160	162.34	80	53.92	42.34	28	
SB4-2040			20	B3	20	60	80	89.62	120	66.59	42.41	35	
SB5-4020		m5	40	B5	25	100	200	202.93	90	55.33	42.93	26	
SB5-2040			20	B3	20	80	100	112.03	140	68.92	43.01	35	
SB6-4020		m6	40	B5	25	85	240	243.52	105	65.05	48.52	28	
SB6-2040			20	B3	25	90	120	134.44	160	78.16	43.6	32.5	
SBY8-4020	m8	40	BT	35	180	320	324.69	130	75.36	54.69	25		
SBY8-2040		20	B3	30	120	160	179.25	210	98	54.81	40		

* Please see Page 364 for Caution on Product Characteristics and Caution on Secondary Operations.

Catalog Number	L (mm)	Tap Size
SBY8-4020	160	M10 deep 20



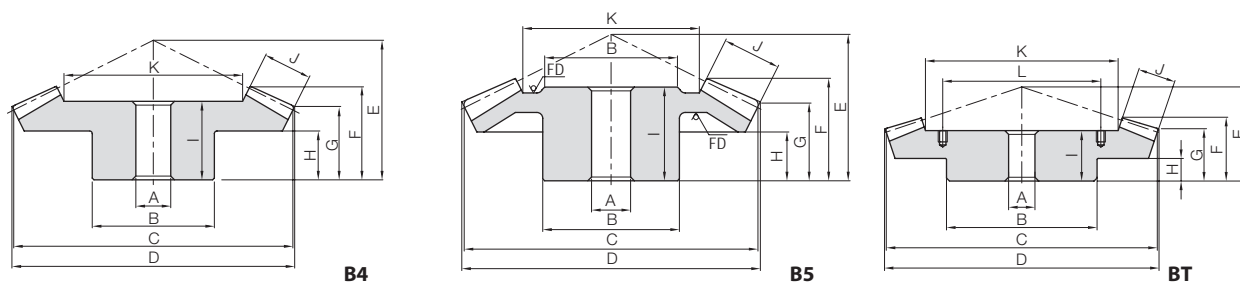

* FD has a forged finish surface.

Hole length I	Face width J	Holding surface dia. K	Allowable torque						Backlash (mm)	Weight (kg)	Catalog Number	
			Bending strength		Surface durability		Surface durability ^H					
			N·m	kgf·m	N·m	kgf·m	N·m	kgf·m				
16	9	27.37	5.82	0.59	0.65	0.07	2.78	0.28	0.05~0.15	0.12	SB1.5-3020	⊕
17		17.05	4.04	0.41	0.44	0.04	1.86	0.19				
23	11	37.56	13.1	1.33	1.52	0.16	6.37	0.65	0.07~0.17	0.55	SB2-3020	⊕
22		21.34	9.07	0.92	1.01	0.10	4.25	0.43				
30	15	45.61	26.9	2.75	3.21	0.33	13.3	1.36	0.12~0.27	0.25	SB2.5-3020	⊕
28		27.42	18.7	1.91	2.14	0.22	8.86	0.90				
31	17	57.14	44.9	4.58	5.45	0.56	22.4	2.29	0.16~0.36	0.83	SB3-3020	⊕
37		34.71	31.2	3.18	3.63	0.37	14.9	1.52				
40	20	78.59	98.2	10.0	12.3	1.25	49.8	5.07	0.20~0.36	1.91	SB4-3020	⊕
43		46.89	68.1	6.95	8.20	0.84	33.2	3.38				
50	30	91.22	215	22.0	27.6	2.81	110	11.2	0.24~0.36	4.13	SB5-3020	⊕
56		54.83	150	15.3	18.4	1.87	73.5	7.49				
15	8	28.36	5.02	0.51	0.47	0.05	2.02	0.21	0.05~0.15	0.10	SB1.5-3015	⊕
15.5		10.72	2.60	0.24	0.02	1.01	0.10	0.10				
18	11	37.4	12.1	1.24	1.18	0.12	4.96	0.51	0.07~0.17	0.21	SB2-3015	⊕
19		16.81	6.28	0.64	0.59	0.06	2.48	0.25				
24	15	44.21	24.9	2.54	2.48	0.25	10.3	1.05	0.09~0.18	0.41	SB2.5-3015	⊕
29		16.42	12.9	1.32	1.24	0.13	5.16	0.53				
30	20	47.78	45.6	4.65	4.60	0.47	19.1	1.94	0.11~0.18	0.83	SB3-3015	⊕
41		19.56	23.6	2.41	2.30	0.23	9.53	0.97				
36	25	70.1	104	10.7	10.9	1.11	44.4	4.53	0.13~0.27	1.64	SB4-3015	⊕
46		32.2	54.0	5.51	5.43	0.55	22.2	2.26				
48	30	90.41	199	20.3	21.3	2.17	85.7	8.74	0.15~0.34	2.72	SB5-3015	⊕
58		32.83	103	10.5	10.6	1.09	42.9	4.37				
57	35	109.74	336	34.2	36.9	3.77	147	15.0	0.17~0.36	4.75	SB6-3015	⊕
63		45.47	174	17.7	18.5	1.88	73.5	7.50				
24	16	57.72	35.9	3.66	4.08	0.42	16.8	1.72	0.07~0.17	0.72	SB2.5-3618	⊕
32		25.44	18.1	1.84	2.04	0.21	8.42	0.86				
30	20	68.28	63.7	6.49	7.34	0.75	30.1	3.07	0.09~0.18	1.15	SB3-3618	⊕
37		28.56	32.0	3.27	3.67	0.37	15.1	1.54				
42	26	91.86	149	15.2	17.7	1.80	71.3	7.27	0.11~0.27	2.66	SB4-3618	⊕
49		39.72	74.8	7.62	8.85	0.90	35.7	3.64				
12	6	26.58	2.61	0.27	0.29	0.03	1.26	0.13	0.03~0.13	0.068	SB1-4020	⊕
12		9.17	1.32	0.13	0.15	0.02	0.63	0.065				
16	8	33.61	5.33	0.54	0.61	0.06	2.61	0.27	0.05~0.15	0.14	SB1.25-4020	⊕
17		13.22	2.69	0.27	0.31	0.03	1.30	0.13				
22	10	39.64	9.47	0.97	1.11	0.11	4.68	0.48	0.07~0.17	0.27	SB1.5-4020	⊕
24		17.28	4.77	0.49	0.56	0.06	2.34	0.24				
27	15	48.46	24.2	2.46	2.92	0.30	12.1	1.24	0.09~0.18	0.51	SB2-4020	⊕
32		20.92	12.2	1.24	1.46	0.15	6.06	0.62				
35	20	60.28	49.0	4.99	6.04	0.62	24.9	2.54	0.11~0.18	1.09	SB2.5-4020	⊕
41		24.56	24.7	2.52	3.02	0.31	12.4	1.27				
38	22	73.81	80.4	8.20	10.1	1.03	41.3	4.21	0.13~0.36	1.68	SB3-4020	⊕
47		29.61	40.5	4.13	5.06	0.52	20.6	2.11				
45	28	102.39	185	18.9	24.1	2.46	96.5	9.84	0.15~0.36	3.34	SB4-4020	⊕
62		42.78	93.3	9.51	12.0	1.23	48.2	4.92				
50	30	138.92	327	33.3	43.9	4.47	172	17.5	0.17~0.36	5.63	SB5-4020	⊕
63		57.84	165	16.8	21.9	2.24	86.0	8.77				
58	40	158.56	600	61.2	83.2	8.48	321	32.8	0.19~0.36	7.77	SB6-4020	⊕
70		61.11	302	30.8	41.6	4.24	161	16.4				
61	50	219.2	1350	138	196	20.0	739	75.4	0.21~0.45	25.75	SBY8-4020	⊕
90		96.39	679	69.3	98.1	10.0	370	37.7				

For the handling conveniences, the products listed on the left have the tapped holes (180° apart, 2 places) on the holding surface.



Specifications	
Precision grade	JIS B 1704: 1978 grade 3
Gear teeth	Gleason
Pressure angle	20°
Material	S45C
Heat treatment	—
Tooth hardness	(less than 194HB)
Surface treatment	Black oxide coating

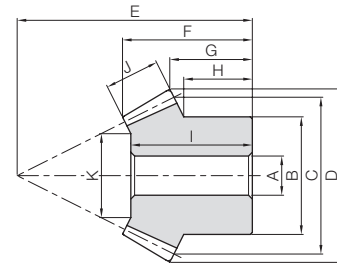

B3

H To order Hardened Plus, please specify **Catalog No. + H**. Example: **SB1-4518H**

Catalog Number	Gear Ratio	Module	No. of teeth	Shape	Bore	Hub dia.	Pitch dia.	Outside dia.	Mounting distance	Total length	Crown to back	Hub width
					A _{H7}	B	C	D	E	F	G	H
SB1-4518 SB1-1845	2.5	m1	45	B4	8	30	45	45.46	23	16.95	14.57	10
18			B3	6	15	18	20.57	32	16.34	10.02	8.9	
SB1.5-4518 SB1.5-1845		m1.5	45	B4	10	36	67.5	68.18	30	21.1	17.35	10
18			B3	8	23	27	30.86	45	21.97	12.02	10.45	
SB2-4518 SB2-1845		m2	45	B4	12	48	90	90.91	40	27.91	23.14	15
18			B3	10	32	36	41.15	60	28.69	16.03	14.2	
SB2.5-4518 SB2.5-1845		m2.5	45	B4	15	55	112.5	113.64	50	35.06	28.92	18
18			B3	12	40	45	51.44	72	33.31	17.04	14.75	
SB3-4518 SB3-1845		m3	45	B4	20	65	135	136.37	60	41.86	34.71	22
18			B3	16	48	54	61.72	85	38.04	19.05	16.3	
SB4-4518 SB4-1845		m4	45	B4	20	80	180	181.82	75	51.16	41.28	24
18			B3	20	62	72	82.3	110	48.28	22.06	18	
SB5-4518 SB5-1845	m5	45	B4	25	100	225	227.28	90	59.43	47.85	28	
18		B3	20	80	90	102.87	135	55.82	25.07	20.5		
SB1-4515 SB1-1545	3	m1	45	B4	8	30	45	45.37	17	11.77	10.06	5
15			B3	6	12	15	17.67	29	12.51	6.95	6	
SB1.25-4515 SB1.25-1545		m1.25	45	B4	10	34	56.25	56.72	21	14.61	12.33	6
15			B3	8	15	18.75	22.09	36	15.85	8.43	7.25	
SB1.5-4515 SB1.5-1545		m1.5	45	B4	10	36	67.5	68.06	28	20.44	17.59	11
15			B3	8	18	22.5	26.54	47	23.19	13.92	12.5	
SB2-4515 SB2-1545		m2	45	B4	12	40	90	90.75	40	30.4	26.12	17
15			B3	10	24	30	35.35	60	29.8	15.89	14	
SB2.5-4515 SB2.5-1545		m2.5	45	B4	15	50	112.5	113.43	50	38.35	32.65	22
15			B3	12	30	37.5	44.18	75	38.41	19.86	17.5	
SB3-4515 SB3-1545		m3	45	B4	20	60	135	136.12	55	40.74	34.18	20
15			B3	15	38	45	53.02	90	45.17	23.84	21.33	
SB4-4515 SB4-1545		m4	45	B5	20	80	180	181.5	70	50.79	42.24	24
15			B3	16	50	60	70.69	115	54.6	26.78	23.33	
SB5-4515 SB5-1545		m5	45	B5	25	90	225	226.87	75	50.28	40.3	20
15			B3	20	60	75	88.37	145	67.19	34.73	30	
SB6-4515 SB6-1545		m6	45	BT	30	160	270	272.24	100	72.62	58.36	30
15			B3	25	70	90	106.03	175	89.04	42.67	36.67	
SBY8-4515 SBY8-1545	m8	45	BT	35	200	360	362.99	125	83.74	69.49	30	
15		B3	30	100	120	141.39	230	99.93	53.56	46.67		

[Caution on Product Characteristics] ① For the handling conveniences, the BT series has the tapped holes on the holding surface. Please see the table on the right for L and tap sizes.

[Caution on Secondary Operations] ① See Page 22 for more details on Hardened Plus (H Series and HJ Series).



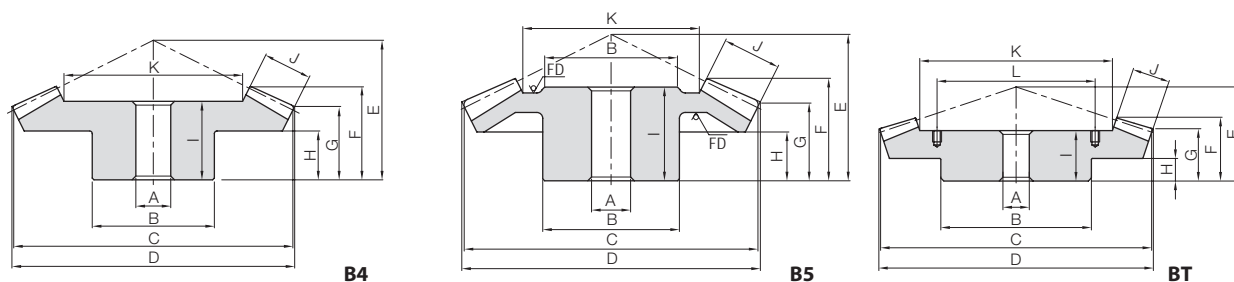

* FD has a forged finish surface.

Hole length I	Face width J	Holding surface dia. K	Allowable torque						Backlash (mm)	Weight (kg)	Catalog Number
			Bending strength		Surface durability		Surface durability H				
			N·m	kgf·m	N·m	kgf·m	N·m	kgf·m			
15 15.5	7	30.73 10.31	3.35 1.33	0.34 0.14	0.35 0.14	0.04 0.01	1.52 0.61	0.15 0.062	0.03~0.13	0.11 0.019	SB1-4518 SB1-1845
18 21	11	45 16.51	11.7 4.64	1.19 0.47	1.29 0.51	0.13 0.05	5.39 2.16	0.55 0.22	0.05~0.15	0.28 0.063	SB1.5-4518 SB1.5-1845
25 27.5	14	62.24 23.11	26.8 10.7	2.74 1.09	3.05 1.22	0.31 0.12	12.6 5.05	1.29 0.52	0.06~0.16	0.65 0.16	SB2-4518 SB2-1845
31 31.5	18	76.53 26.82	53.4 21.2	5.44 2.16	6.20 2.48	0.63 0.25	25.4 10.2	2.59 1.04	0.07~0.17	1.23 0.28	SB2.5-4518 SB2.5-1845
37 36	21	92.96 33.41	90.5 36.0	9.23 3.67	10.7 4.29	1.09 0.44	43.5 17.4	4.44 1.78	0.08~0.18	2.05 0.46	SB3-4518 SB3-1845
45 46	29	122.33 45.83	220 87.3	22.4 8.91	26.8 10.7	2.73 1.09	107 42.8	10.9 4.37	0.12~0.27	4.69 1.01	SB4-4518 SB4-1845
51 52.5	34	156.56 56.9	411 164	41.9 16.7	51.8 20.7	5.28 2.11	202 81.0	20.6 8.26	0.14~0.34	8.31 1.95	SB5-4518 SB5-1845
9 12	6	32.02 10.05	2.84 0.98	0.29 0.10	0.27 0.09	0.027 0.0091	1.15 0.38	0.12 0.039	0.03~0.13	0.078 0.095	SB1-4515 SB1-1545
12 15	8	39.63 10.9	5.80 2.00	0.59 0.20	0.56 0.19	0.057 0.019	2.38 0.79	0.24 0.081	0.04~0.14	0.15 0.018	SB1.25-4515 SB1.25-1545
17 22.5	10	46.58 14.75	10.3 3.56	1.05 0.36	1.02 0.34	0.10 0.035	4.27 1.42	0.44 0.15	0.05~0.15	0.25 0.041	SB1.5-4515 SB1.5-1545
26 29	15	59.04 19.13	26.4 9.10	2.69 0.93	2.68 0.89	0.27 0.091	11.1 3.70	1.13 0.38	0.06~0.16	0.60 0.096	SB2-4515 SB2-1545
35 37	20	72.84 20.51	53.6 18.5	5.46 1.89	5.55 1.85	0.57 0.19	22.8 7.61	2.33 0.78	0.07~0.17	1.22 0.19	SB2.5-4515 SB2.5-1545
35 43	23	88.18 22.53	90.2 31.2	9.20 3.18	9.53 3.18	0.97 0.32	38.9 13.0	3.96 1.32	0.08~0.18	1.99 0.34	SB3-4515 SB3-1545
45 52	30	118.09 32.26	211 72.8	21.5 7.43	23.0 7.67	2.35 0.78	92.1 30.7	9.40 3.13	0.12~0.27	3.89 0.77	SB4-4515 SB4-1545
44 65	35	152.88 48.64	394 136	40.2 13.9	44.3 14.8	4.52 1.51	174 58.0	17.7 5.91	0.14~0.34	6.10 1.46	SB5-4515 SB5-1545
62 86	50	169.26 49.77	751 259	76.6 26.4	87.0 39.9	8.87 4.06	337 112	34.3 11.4	0.16~0.36	18.0 2.61	SB6-4515 SB6-1545
67 93	50	255.92 61.77	1470 506	150 51.6	179 59.7	18.3 6.09	674 225	68.8 22.9	0.20~0.45	36.4 5.80	SBY8-4515 SBY8-1545

For the handling conveniences, the products listed in the table below have the tapped holes (180° apart, 2 places) on the holding surface.

Catalog Number	L (mm)	Tap Size
SB6-4515	130	M10, 20mm deep
SBY8-4515	210	M10, 20mm deep

- Spur Gears
- Helical Gears
- Internal Gears
- Racks
- CP Racks & Pinions
- Miter Gears
- Bevel Gears
- Screw Gears
- Worm Gears
- Gearboxes
- Other Products



Specifications	
Precision grade	JIS B 1704: 1978 grade 3
Gear teeth	Gleason
Pressure angle	20°
Material	S45C
Heat treatment	—
Tooth hardness	(less than 194HB)
Surface treatment	Black oxide coating

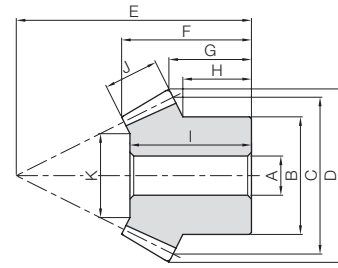

B3

H To order Hardened Plus, please specify **Catalog No. + H**. Example: **SB1.5-6015H**

Catalog Number	Gear Ratio	Module	No. of teeth	Shape	Bore	Hub dia.	Pitch dia.	Outside dia.	Mounting distance	Total length	Crown to back	Hub width
					AH7	B	C	D	E	F	G	H
SB1.5-6015	4	m1.5	60	B4	12	50	90	90.41	32	24.2	21.58	12
SB1.5-1560			15	B3	8	18	22.5	26.66	56	23.01	11.52	10.43
SB2-6015		m2	60	B4	15	60	120	120.55	42	31.6	28.1	16
SB2-1560			15	B3	10	24	30	35.55	75	31.01	15.69	14.25
SB2.5-6015		m2.5	60	B4	20	70	150	150.69	53	40	35.63	20
SB2.5-1560			15	B3	12	30	37.5	44.44	94	39.02	19.87	18.06
SB3-6015		m3	60	B4	20	80	180	180.83	64	47.97	43.15	25
SB3-1560			15	B3	15	38	45	53.33	112	44.1	23.04	21.12
SB4-6015		m4	60	B5	25	85	240	241.1	80	59.2	52.2	36
SB4-1560			15	B3	16	50	60	71.1	150	62.03	31.4	28.75
SBY5-6015		m5	60	BT	30	180	300	301.36	80	53.97	45.22	20
SBY5-1560			15	B3	25	60	75	88.9	185	75.03	36.74	33.13
SBY6-6015	m6	60	BT	35	200	360	361.66	100	68.16	58.31	25	
SBY6-1560		15	B3	25	75	90	106.66	220	85.17	42.08	38.13	

[Caution on Product Characteristics] ① For the handling conveniences, the BT series has the tapped holes on the holding surface. Please see the table on the right for L and tap sizes.

[Caution on Secondary Operations] ① See Page 22 for more details on Hardened Plus (H Series and HJ Series).



Specifications	
Precision grade	JIS B 1704: 1978 grade 3
Gear teeth	Gleason
Pressure angle	20°
Material	S45C
Heat treatment	—*
Tooth hardness	(less than 194HB)*
Surface treatment	Black oxide coating

* B8 products use thermal refined materials, so the teeth hardness is 200 to 270 HB.

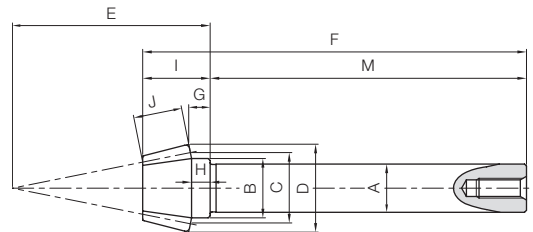

B8

H To order Hardened Plus, please specify **Catalog No. + H**. Example: **SB1.5-6012H**

Catalog Number	Gear Ratio	Module	No. of teeth	Shape	Bore/Shaft Dia.	Hub dia.	Pitch dia.	Outside dia.	Mounting distance	Total length	Crown to back	Hub width	Length of bore and shaft
					A _{AV} (bore) A _{AV} (shaft)	B	C	D	E	F	G	H	I
SB1.5-6012	5	m1.5	60	B4	12	50	90	90.33	30	23.89	21.82	12	21
SB1.5-1260			12	B8	12.2	15	18	22.24	50	97.06	5.42	4.7	17.06
SB2-6012		m2	60	B4	15	60	120	120.43	40	31.85	29.09	16	27
SB2-1260			12	B8	15.2	20	24	29.65	66	117.08	6.56	5.6	22.08
SB2.5-6012		m2.5	60	B4	20	70	150	150.54	50	39.81	36.36	20	34
SB2.5-1260			12	B8	20.2	25	30	37.06	83	143.1	8.7	7.5	28.1
SB3-6012		m3	60	B4	20	80	180	180.65	60	47.43	43.64	25	41
SB3-1260			12	B8	25.25	30	36	44.48	100	172.19	10.85	9.4	32.19

[Caution on Secondary Operations] ① See Page 22 for more details on Hardened Plus (H Series and HJ Series).



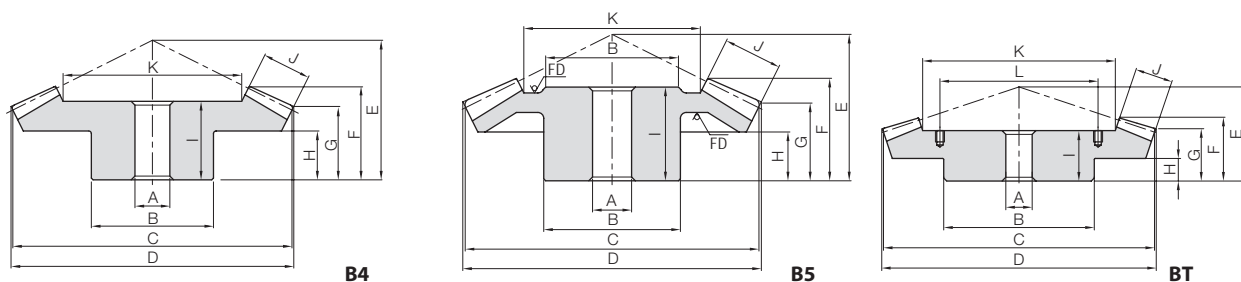

* FD has a forged finish surface.

Hole length I	Face width J	Holding surface dia. K	Allowable torque						Backlash (mm)	Weight (kg)	Catalog Number	
			Bending strength		Surface durability		Surface durability H					
			N·m	kgf·m	N·m	kgf·m	N·m	kgf·m				
21 22.5	12	65.38 15.54	17.3 4.46	1.77 0.45	1.75 0.44	0.18 0.045	7.28 1.82	0.74 0.19	0.05~0.15	0.62 0.043	SB1.5-6015 SB1.5-1560	H H
27 30	16	87.02 18.06	41.3 10.6	4.21 1.08	4.30 1.07	0.44 0.11	17.5 4.38	1.79 0.45	0.06~0.16	1.35 0.10	SB2-6015 SB2-1560	H H
34 37.5	20	108.64 20.57	80.2 20.6	8.18 2.10	8.54 2.13	0.87 0.22	34.6 8.66	3.53 0.88	0.07~0.17	2.51 0.21	SB2.5-6015 SB2.5-1560	H H
41 43	22	134.4 31.58	130 33.5	13.3 3.42	14.2 3.54	1.44 0.36	56.8 14.2	5.79 1.45	0.08~0.18	4.16 0.36	SB3-6015 SB3-1560	H H
53 60	32	174.03 36.12	328 84.5	33.5 8.62	37.0 9.24	3.77 0.94	145 36.2	14.8 3.70	0.12~0.27	6.00 0.91	SB4-6015 SB4-1560	H H
45 73	40	218.79 49.15	642 165	65.4 16.8	74.4 18.6	7.59 1.90	286 71.4	29.1 7.28	0.14~0.34	17.5 1.58	SBY5-6015 SBY5-1560	H H
56 82	45	267.73 54.92	1050 270	107 27.5	126 31.5	12.8 3.21	475 119	48.4 12.1	0.16~0.36	30.7 2.83	SBY6-6015 SBY6-1560	H H

For the handling conveniences, the products listed in the table below have the tapped holes (180° apart, 2 places) on the holding surface.

Catalog Number	L (mm)	Tap Size
SBY5-6015	160	M10, 20mm deep
SBY6-6015	220	M10, 20mm deep

Bevel Gears & Pinion Shafts

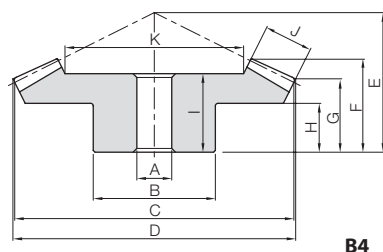

B4

Face width J	Holding surface dia. K	Length of shaft M	Socket head screw Size	Allowable torque						Backlash (mm)	Weight (kg)	Catalog Number	
				Bending strength		Surface durability		Surface durability H					
				N·m	kgf·m	N·m	kgf·m	N·m	kgf·m				
12	65.52 —	— 80	— M5	18.0 4.01	1.83 0.41	1.41 0.46	0.14 0.047	5.85 1.17	0.60 0.12	0.05~0.15	0.62 0.097	SB1.5-6012 SB1.5-1260	H H
16	86.96 —	— 95	— M6	42.6 9.50	4.34 0.97	3.43 1.12	0.35 0.11	14.1 2.82	1.44 0.29	0.06~0.16	1.34 0.19	SB2-6012 SB2-1260	H H
20	108.8 —	— 115	— M8	83.2 18.5	8.48 1.89	6.85 2.23	0.70 0.23	27.9 5.57	2.84 0.57	0.07~0.17	2.54 0.40	SB2.5-6012 SB2.5-1260	H H
22	134.73 —	— 140	— M8	135 30.1	13.8 3.07	11.4 3.70	1.16 0.38	45.7 9.13	4.66 0.93	0.08~0.18	4.18 0.74	SB3-6012 SB3-1260	H H



Specifications	
Precision grade	JIS B 1704: 1978 grade 3
Gear teeth	Gleason
Pressure angle	20°
Material	SUS303
Heat treatment	—
Tooth hardness	(less than 187HB)

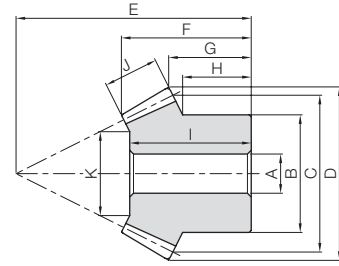

B3

Catalog Number	Gear Ratio	Module	No. of teeth	Shape	Bore	Hub dia.	Pitch dia.	Outside dia.	Mounting distance	Total length	Crown to back	Hub width
					A _{H7}	B	C	D	E	F	G	H
SUB1.5-3020	1.5	m1.5	30	B4	10	30	45	46.24	28	18.53	13.93	8
SUB1.5-2030			20	B3	8	25	30	33.13	33	18.63	11.54	8.83
SUB2-3020		m2	30	B4	10	35	60	61.65	40	26.87	21.24	15
SUB2-2030			20	B3	10	35	40	44.18	45	25.06	16.39	13.33
SUB2.5-3020		m2.5	30	B4	15	45	75	77.07	50	34.22	26.55	18
SUB2.5-2030			20	B3	12	40	50	55.22	55	31.06	19.24	14.16
SUB3-3020	m3	30	B4	15	60	90	92.48	55	35.56	26.86	17	
SUB3-2030		20	B3	15	50	60	66.27	70	40.48	27.09	21.66	
SUB1.5-4020	2	m1.5	40	B4	10	38	60	60.88	35	25.01	20.88	15
SUB1.5-2040			20	B3	8	25	30	33.61	46	25.54	16.9	14.75
SUB2-4020		m2	40	B4	12	50	80	81.17	45	32.37	26.17	18
SUB2-2040			20	B3	12	32	40	44.81	60	34.16	21.2	18
SUB2.5-4020		m2.5	40	B4	15	60	100	101.46	55	39.73	31.46	20
SUB2.5-2040			20	B3	12	40	50	56.01	75	43.78	26.5	22.5
SUB3-4020	m3	40	B4	20	70	120	121.76	65	45.85	36.76	24	
SUB3-2040		20	B3	16	50	60	67.22	90	50.81	31.8	27.5	
SUB1.5-4515	3	m1.5	45	B4	10	36	67.5	68.06	28	20.44	17.59	11
SUB1.5-1545			15	B3	8	18	22.5	26.54	47	23.19	13.92	12.5
SUB2-4515		m2	45	B4	12	60	90	90.75	40	30.4	26.12	17
SUB2-1545			15	B3	10	24	30	35.35	60	29.8	15.89	14
SUB2.5-4515		m2.5	45	B4	15	60	112.5	113.43	50	38.35	32.65	22
SUB2.5-1545			15	B3	12	30	37.5	44.18	75	38.41	19.86	17.5
SUB3-4515	m3	45	B4	20	80	135	136.12	55	40.74	34.18	20	
SUB3-1545		15	B3	15	38	45	53.02	90	45.17	23.84	21.33	

- Spur Gears
- Helical Gears
- Internal Gears
- Racks
- CP Racks & Pinions
- Miter Gears
- Bevel Gears
- Screw Gears
- Worm Gears
- Gearboxes
- Other Products



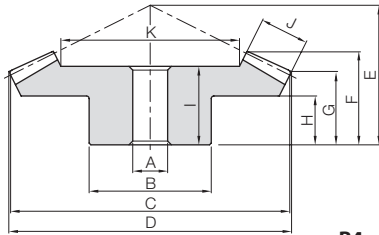

B4

Hole length I	Face width J	Holding surface dia. K	Allowable torque (N-m)		Allowable torque (kgf-m)		Backlash (mm)	Weight (kg)	Catalog Number
			Bending strength	Surface durability	Bending strength	Surface durability			
16 17	9	27.37 17.05	3.22 2.23	0.46 0.31	0.33 0.23	0.047 0.032	0.05~0.15	0.12 0.064	SUB1.5-3020 SUB1.5-2030
23 22	11	37.56 21.34	7.22 5.01	1.08 0.72	0.74 0.51	0.11 0.074	0.06~0.16	0.27 0.16	SUB2-3020 SUB2-2030
30 28	15	45.61 27.42	14.9 10.3	2.28 1.52	1.52 1.05	0.23 0.15	0.07~0.17	0.55 0.29	SUB2.5-3020 SUB2.5-2030
31 37	17	57.14 34.71	24.8 17.2	3.87 2.58	2.53 1.76	0.39 0.26	0.08~0.18	0.95 0.56	SUB3-3020 SUB3-2030
22 24	10	39.64 17.28	5.23 2.64	0.79 0.40	0.53 0.27	0.081 0.040	0.05~0.15	0.27 0.090	SUB1.5-4020 SUB1.5-2040
27 32	15	48.46 20.92	13.4 6.72	2.07 1.04	1.36 0.69	0.21 0.11	0.06~0.16	0.62 0.19	SUB2-4020 SUB2-2040
35 41	20	60.28 24.56	27.1 13.6	4.29 2.15	2.76 1.39	0.44 0.22	0.07~0.17	1.24 0.41	SUB2.5-4020 SUB2.5-2040
38 47	22	73.81 29.61	44.4 22.4	7.19 3.60	4.53 2.28	0.73 0.37	0.08~0.18	1.89 0.70	SUB3-4020 SUB3-2040
17 22.5	10	46.58 14.75	5.70 1.97	0.72 0.24	0.58 0.20	0.074 0.025	0.05~0.15	0.25 0.041	SUB1.5-4515 SUB1.5-1545
26 29	15	59.04 19.13	14.6 5.03	1.90 0.63	1.49 0.51	0.19 0.065	0.06~0.16	0.82 0.097	SUB2-4515 SUB2-1545
35 37	20	72.84 20.51	29.6 10.2	3.94 1.31	3.02 1.04	0.40 0.13	0.07~0.17	1.38 0.19	SUB2.5-4515 SUB2.5-1545
35 43	23	88.18 22.53	49.9 17.2	6.77 2.26	5.09 1.76	0.69 0.23	0.08~0.18	2.36 0.34	SUB3-4515 SUB3-1545

Spur Gears

Helical Gears

Internal Gears

Racks

CP Racks & Pinions

Miter Gears

Bevel Gears

Screw Gears

Worm Gears

Gearboxes

Other Products



Specifications	
Precision grade	JIS B 1704: 1978 grade 4*
Gear teeth	Gleason
Pressure angle	20°
Material	MC901
Heat treatment	—
Tooth hardness	(115 to 120HRR)

* The precision grade is equivalent to the value shown in the table.

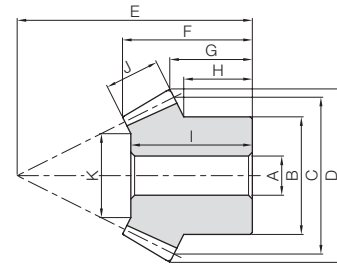

B3

Catalog Number	Gear Ratio	Module	No. of teeth	Shape	Bore		Hub dia.		Pitch dia.		Outside dia.		Mounting distance		Total length		Crown to back		Hub width	
					A	B	C	D	E	F	G	H								
PB1.5-3020 PB1.5-2030	1.5	m1.5	30	B4	10	30	45	46.24	28	18.53	13.93	8								
20			B3	8	25	30	33.13	33	18.63	11.54	8.83									
PB2-3020 PB2-2030		m2	30	B4	10	35	60	61.65	40	26.87	21.24	15								
20			B3	10	35	40	44.18	45	25.06	16.39	13.33									
PB1-4020 PB1-2040	2	m1	40	B4	8	25	40	40.59	22	15.07	12.59	8								
20			B3	6	16	20	22.41	28	13.78	8.6	7									
PB1.25-4020 PB1.25-2040		m1.25	40	B4	10	32	50	50.73	27	18.54	15.23	10								
20			B3	8	22	25	28.01	36	18.66	11.75	10.25									
PB1.5-4020 PB1.5-2040		m1.5	40	B4	10	38	60	60.88	35	25.01	20.88	15								
20			B3	8	25	30	33.61	46	25.54	16.9	14.75									
PB2-4020 PB2-2040	m2	40	B4	12	40	80	81.17	45	32.37	26.17	18									
20		B3	12	32	40	44.81	60	34.16	21.2	18										
PB1.5-4515 PB1.5-1545	3	m1.5	45	B4	10	40	67.5	68.06	28	20.44	17.59	11								
15			B3	8	18	22.5	26.54	47	23.19	13.92	12.5									
PB2-4515 PB2-1545		m2	45	B4	12	60	90	90.75	40	30.4	26.12	17								
15			B3	10	24	30	35.35	60	29.8	15.89	14									

[Caution on Product Characteristics] ① To reduce heat generation, it is recommended to mate plastic gears with steel gears.

* In regard to MC Nylon gears, other materials are available for plastic gears, including Ultra High Molecular Weight Polyethylene (U-PE), which has excellent abrasion resistance and resin conforming to the Plastic Implementation Measure (PIM). A single piece order is acceptable and will be produced as a custom-made gear. Please see Page 26 for more details on quotations and orders.



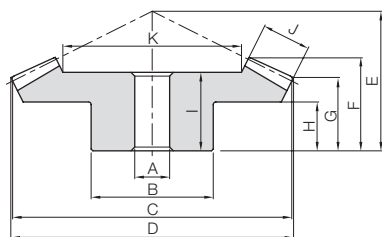

B4

Hole length I	Face width J	Holding surface dia. K	Allowable torque (N·m)		Allowable torque (kgf·m)		Backlash (mm)	Weight (kg)	Catalog Number
			Bending strength	Surface durability	Bending strength	Surface durability			
16 17	9	27.37 17.05	1.61 0.87	—	0.16 0.089	—	0~0.25	0.018 0.0093	PB1.5-3020 PB1.5-2030
23 22	11	37.56 21.34	3.65 1.97		0.37 0.20		0~0.26	0.039 0.024	PB2-3020 PB2-2030
12 12	6	26.58 9.17	0.74 0.28	—	0.075 0.028	—	0~0.23	0.010 0.0029	PB1-4020 PB1-2040
16 17	8	33.61 13.22	1.50 0.56		0.15 0.058		0~0.24	0.021 0.0068	PB1.25-4020 PB1.25-2040
22 24	10	39.64 17.28	2.66 1.00	—	0.27 0.10	—	0~0.25	0.039 0.013	PB1.5-4020 PB1.5-2040
27 32	15	48.46 20.92	6.72 2.52		0.69 0.26		0~0.26	0.076 0.028	PB2-4020 PB2-2040
17 22.5	10	46.58 14.75	3.18 0.68	—	0.32 0.070	—	0~0.25	0.040 0.0061	PB1.5-4515 PB1.5-1545
26 29	15	59.04 19.13	8.07 1.73		0.82 0.18		0~0.26	0.12 0.014	PB2-4515 PB2-1545

Spur
Gears

Helical
Gears

Internal
Gears

Racks

CP Racks &
Pinions

Miter
Gears

Bevel
Gears

Screw
Gears

Worm
Gears

Gearboxes

Other
Products



Specifications	
Precision grade	JIS B 1704: 1978 grade 6
Gear teeth	Gleason
Pressure angle	20°
Material	Duracon (R) (M90-44)
Heat treatment	—
Tooth hardness	(110 to 120HRR)

* "Duracon (R)" is a registered trademark of Polyplastics Co., Ltd. in Japan as well as other countries.

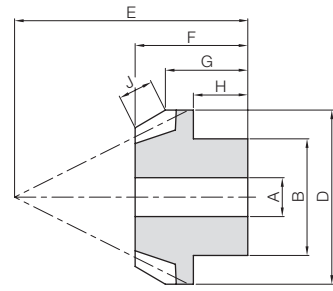

B1

Catalog Number	Gear Ratio	Module	No. of teeth	Shape	Bore	Hub dia.	Pitch dia.	Outside dia.	Mounting distance	Total length	Crown to back
					A	B		D	E	F	G
DB0.5-4020	2	m0.5	40	B9	4	12	20	20.29	12	8.33	7.29
DB0.5-2040			20	B1	3	8	10	11.2	16	8.46	6.3
DB0.8-4020		m0.8	40	B9	5	15	32	32.47	18	11.91	10.47
DB0.8-2040			20	B1	4	12	16	17.92	24	11.5	8.48
DB1-4020		m1	40	B9	6	18	40	40.59	22	14.45	12.59
DB1-2040			20	B1	5	15	20	22.4	30	14.49	10.6

[Caution on Product Characteristics] ① The bore tolerance is -0.05 to -0.30, but it may be slightly higher at the center of the hole.

② For the dimensional accuracy of each part, see the dimensional tolerance of molded items in the table at right.

[Caution on Secondary Operations] ① As it is a molded item, bubbles may form inside the material. Avoid performing secondary operations.



BB

Sintered Metal Bushings

Sintered Metal Bushings



When using the injection molded bevel gear as an idler gear and a shaft diameter smaller than the inside diameter of the molded gear, please press fit one of the following standard bushings.

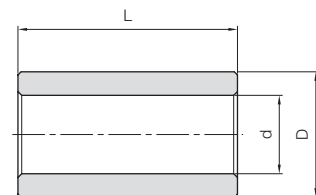

T8

Catalog Number	Inner dia.	Outside dia.	Length	Gear example
	$d \begin{smallmatrix} +0.02 \\ 0 \end{smallmatrix}$	$D \begin{smallmatrix} +0.02 \\ -0.01 \end{smallmatrix}$	$L \begin{smallmatrix} 0 \\ -0.3 \end{smallmatrix}$	
BB30507	3	5	7	DB0.8
BB40612	4	6	12	DB1

Material: Oil-free copper alloy



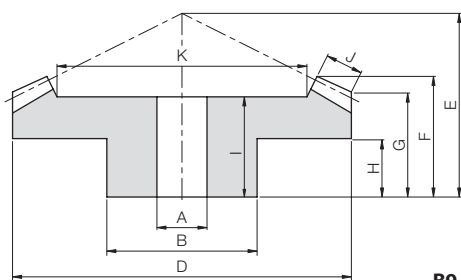

B9

Hub width H	Hole length I	Face width J	Holding surface dia. K	Allowable torque (N·m)		Backlash (mm)	Weight (g)	Catalog Number
				Bending strength	Bending strength			
4	7	2.5	14.41	0.24	0.025	0~0.30	2.00	DB0.5-4020
4	—		—	0.092	0.0094		0.54	DB0.5-2040
6	10	3.5	24.17	0.91	0.093	0~0.48	6.26	DB0.8-4020
5	—		—	0.34	0.035		1.87	DB0.8-2040
7.5	12.5	4.5	30.44	1.59	0.16	0~0.60	11.9	DB1-4020
7	—		—	0.60	0.061		3.54	DB1-2040

■ Dimensional tolerance of molded item (unit: mm)

Dimensional classification	Grade	Rough grade
	3 or less	
4 to 6		±0.25
7 to 10		±0.30
11 to 18		±0.35
19 to 30		±0.40
Over 30		±0.50

Spur Gears

Helical Gears

Internal Gears

Racks

CP Racks & Pinions

Miter Gears

Bevel Gears

Screw Gears

Worm Gears

Gearboxes

Other Products



- Spur Gears
- Helical Gears
- Internal Gears
- Racks
- CP Racks & Pinions
- Miter Gears
- Bevel Gears
- Screw Gears
- Worm Gears
- Gearboxes
- Other Products



■ Catalog number

Note that the catalog numbers for KSP ground spiral bevel gears have a different configuration compared to other miters and bevel gears.

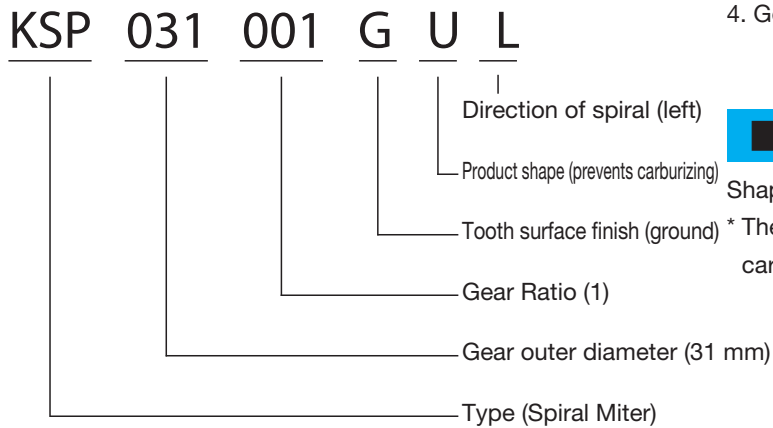

■ Features of KSP spiral bevel gears

1. High-strength, high-precision product of JIS grade 0.
2. Superior performance with regard to high speed, low noise, and low vibration.
3. Module is 1.5 to 6
4. Gear ratio types are 1, 1.5 and 2

■ Shape

Shape for secondary operations (with margin)

* The parts ----- in the figure below are protected from carburizing.

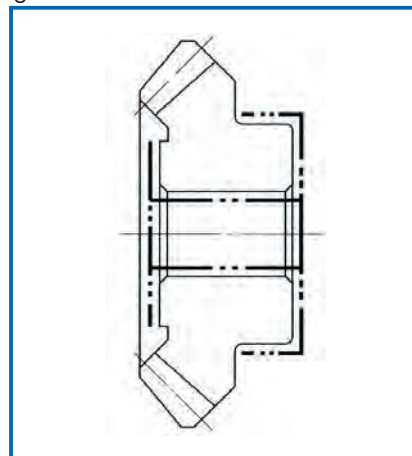

Transmission capacity table

- The values in the transmission capacity table below are where the service factor is 1. Be sure to correct the load torque according to the table on the right. The corrected load torque is calculated by multiplying the load torque applied to the output shaft by service factor (Sf).
 - When using at increased speed (where gear is drive and pinion is driven), the torque of the pinion is the value obtained by multiplying the value shown in the transmission capacity table by the speed ratio.
- NOTE 1: When the speed ratio is 1/1.5, the pinion torque is 1/1.5 of the value shown in the transmission capacity table.

Service factor (Sf)

Impact from motor	Impact from load		
	Uniform load	Moderate impact	Severe impact
Uniform load (electric motor, turbine, hydraulic motor, etc.)	1.0	1.25	1.75
Mild impact (multi-cylinder engine)	1.25	1.5	2.0
Moderate impact (single-cylinder engine)	1.5	1.75	2.25

Transmission capacity table (speed ratio 1/1)

Upper transmission capacity (kw) Lower output torque (N-m)

Figure number \ Rotational speed (rpm)	50	100	300	600	900	1200	1800	3000
KSP031001	0.035	0.068	0.195	0.375	0.548	0.716	1.04	1.65
	6.65	6.51	6.20	5.98	5.82	5.69	5.51	5.25
KSP040001	0.092	0.179	0.511	0.980	1.43	1.86	2.69	4.25
	17.6	17.2	16.3	15.6	15.2	14.8	14.3	13.5
KSP053001	0.211	0.412	1.17	2.23	3.25	4.22	6.08	9.55
	40.4	39.3	37.3	35.6	34.5	33.6	32.3	30.4
KSP066001	0.367	0.715	2.02	3.85	5.59	7.26	10.4	16.3
	70.2	68.3	64.4	61.4	59.3	57.8	55.4	52.0
KSP078001	0.577	1.12	3.16	6.00	8.68	11.2	16.1	25.1
	109.8	106.9	101.0	95.5	92.2	89.5	85.5	79.8
KSP092001	0.901	1.75	4.91	9.31	13.5	17.4	24.9	38.6
	172.6	166.7	156.9	148.1	143.2	138.3	132.4	122.6
KSP105001	1.44	2.78	7.80	14.7	21.2	27.4	39.1	60.3
	274.6	265.8	248.1	234.4	225.6	218.7	207.9	192.2
KSP132001	2.33	4.50	12.6	23.6	34.0	43.7	62.0	95.0
	445.2	430.5	400.1	376.6	360.9	348.1	329.5	302.0
KSP157001	3.68	7.10	19.7	37.0	53.0	68.1	96.2	146
	704.1	678.6	628.6	589.4	562.9	542.3	510.9	466.8
KSP184001	5.31	10.2	28.3	52.8	75.5	96.8	136	206
	1010	976.7	901.2	841.4	801.2	770.8	722.8	656.1

Transmission capacity table (speed ratio 1/1.5)

Upper transmission capacity (kw) Lower output torque (N-m)

Figure number \ Rotational Speed of Pinion (rpm)	50	100	300	600	900	1200	1800	3000
KSP0481.5	0.077	0.151	0.432	0.830	1.21	1.58	2.29	3.64
	22.2	21.6	20.6	19.8	19.3	18.9	18.2	17.4
KSP0611.5	0.159	0.309	0.882	1.69	2.46	3.21	4.64	7.33
	45.4	44.3	42.2	40.4	39.2	38.3	37.0	35.0
KSP0741.5	0.277	0.540	1.53	2.93	4.27	5.55	8.00	12.6
	79.4	77.4	73.4	70.1	68.0	66.3	63.7	60.1
KSP0901.5	0.466	0.908	2.57	4.90	7.12	9.24	13.3	20.8
	133.4	130.4	122.6	116.7	113.8	110.8	105.9	99.0
KSP1051.5	0.700	1.36	3.84	7.31	10.6	13.7	19.7	30.7
	201.0	195.2	183.4	174.6	168.7	163.8	156.9	147.1
KSP1241.5	1.03	2.00	5.63	10.7	15.5	20.0	28.6	44.5
	295.2	286.4	268.7	255.0	246.1	239.3	227.5	212.8
KSP1411.5	1.56	3.03	8.51	16.1	23.2	30.1	42.9	66.4
	448.2	434.4	406.0	384.4	370.7	358.9	341.3	317.7
KSP1631.5	2.27	4.39	12.3	23.2	33.4	43.1	61.4	94.6
	650.2	628.6	587.4	554.1	532.5	514.8	489.4	452.1
KSP1811.5	2.92	5.64	15.8	29.7	42.7	55.1	78.3	120
	836.5	809.0	754.1	710.0	680.6	658.0	623.7	574.7

Transmission capacity table (speed ratio 1/2)

Upper transmission capacity (kw) Lower output torque (N-m)

Figure number \ Rotational Speed of Pinion (rpm)	50	100	300	600	900	1200	1800	3000
KSP039002	0.025	0.049	0.142	0.275	0.404	0.528	0.770	1.23
	9.63	9.45	9.07	8.76	8.57	8.41	8.17	7.83
KSP056002	0.075	0.147	0.423	0.814	1.19	1.55	2.26	3.59
	28.8	28.1	27.0	26.0	25.3	24.8	23.9	22.8
KSP075002	0.185	0.361	1.03	1.98	2.89	3.76	5.45	8.61
	70.7	69.0	65.7	63.1	61.3	59.9	57.9	54.8
KSP096002	0.364	0.710	2.02	3.86	5.62	7.31	10.5	16.6
	139.3	135.3	128.5	122.6	119.6	116.7	111.8	105.9
KSP119002	0.649	1.26	3.58	6.82	9.90	12.9	18.5	29.0
	248.1	241.2	227.5	217.7	209.9	205.0	196.1	184.4
KSP145002	1.07	2.08	5.87	11.2	16.2	21.0	30.1	46.9
	408.9	397.2	373.6	356.0	343.2	333.4	319.7	298.1
KSP172002	1.78	3.45	9.72	18.4	26.6	34.5	49.3	76.5
	680.6	660.0	618.8	587.4	565.8	549.2	523.7	487.4

Spur Gears

Helical Gears

Internal Gears

Racks

CP Racks & Pinions

Miter Gears

Bevel Gears

Screw Gears

Worm Gears

Gearboxes

Other Products



Ground Spiral Bevel Gears



Specifications	
Precision grade	JIS B 1704: 1978 grade 0
Gear teeth	Gleason
Pressure angle	20°
Helix angle	35°
Material	SCM415*
Heat treatment	Carburized (Bore and hub are carburized)
Tooth hardness	60 to 63HRC**

* The material of module 3.5 and above is SCM420.
 ** Modules 1.5 and 2 have the tooth hardness of 80 to 83 HRA.

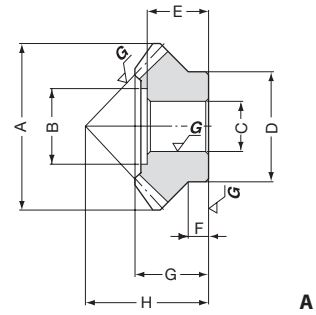

- Spur Gears
- Helical Gears
- Internal Gears
- Racks
- CP Racks & Pinions
- Miter Gears
- Bevel Gears
- Screw Gears
- Worm Gears
- Gearboxes
- Other Products

Catalog Number	Gear Ratio	Module	No. of teeth	Direction of spiral	Pitch dia.	Face width	Shape	Outside dia.	Holding surface dia.	Bore	Hub dia.	Hole length
								A	B	CH7	D	E
KSP031001GU L KSP031001GU R	1	m1.5	20	L R	30	7	A	30.5	16.5	10	22	13
KSP040001GU L KSP040001GU R		m2	20	L R	40	9	B	40	22.5	12	31	14
KSP078001GU L KSP078001GU R		m3.5	22	L R	77	18	B	78	43	20	54	27
KSP105001GU L KSP105001GU R		m4.5	23	L R	103.5	25	C	105	50	26	70	35
KSP132001GU L KSP132001GU R		m5	26	L R	130	29	C	132	64	30	82	41
KSP157001GU L KSP157001GU R		m5.5	28	L R	154	34	C	157	76	32	92	47
KSP184001GU L KSP184001GU R		m6	30	L R	180	38	C	184	84	40	101	51
KSP0481.5GU P KSP0481.5GU G	1.5	m2	16	L	32	9	A'	34	17.5	10	24	13
			24	R	48		B	48	30	12	30	17
KSP0741.5GU P KSP0741.5GU G	1.5	m2.75	18	L	49.5	15	A'	52	27	14	40	20
			27	R	74.25		B	74	44.5	20	50	25
KSP075002GU P KSP075002GU G	2	m2.5	15	L	37.5	14	A'	40	20	12	30	17
			30	R	75		C	75	36	16	44	24
KSP096002GU P KSP096002GU G		m3	16	L	48	18	B	53	23.5	12	36	19
			32	R	96		C	96	46	20	56	29
KSP119002GU P KSP119002GU G	m3.5	m3.5	17	L	59.5	22	A	65	34	16	44	25
			34	R	119		C	119	54	26	63	34

[Caution on Product Characteristics] ① The allowable torque is the value at RPM 600. For other data, see the Transmission Capacity Table.



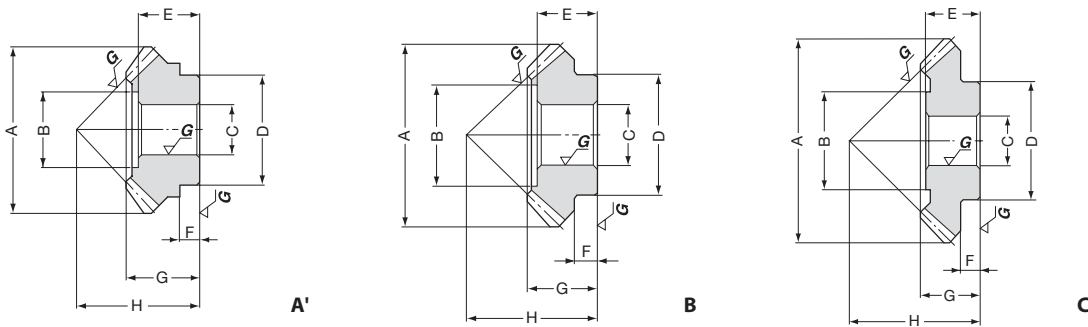

Hub width	Total length	Mounting distance	Machinable MAX bore	Allowable torque (kgf·m)	Backlash (mm)	Weight (kg)	Catalog Number
F	G	H					
6	15	25	12	0.61	0 ~0.05	0.04	KSP031001GU L KSP031001GU R
7	16.5	30	16	1.59	0 ~0.05	0.09	KSP040001GU L KSP040001GU R
12	32	57	32	9.74	0.05~0.10	0.59	KSP078001GU L KSP078001GU R
14	39	72	40	23.9	0.05~0.10	1.33	KSP105001GU L KSP105001GU R
14	45	88	48	38.4	0.05~0.10	2.49	KSP132001GU L KSP132001GU R
20	53.5	105	55	60.1	0.05~0.10	3.90	KSP157001GU L KSP157001GU R
17	56.5	118	62	85.8	0.05~0.10	5.79	KSP184001GU L KSP184001GU R
4.5 7	14.5 19	31 30	— 20	2.02	0 ~0.05	0.05 0.14	KSP0481.5GU P KSP0481.5GU G
6 12	22 29	46 45	20 35	7.15	0.05~0.10	0.20 0.49	KSP0741.5GU P KSP0741.5GU G
4.5 11	19.5 25.5	44 38	14 25	6.43	0.05~0.10	0.10 0.44	KSP075002GU P KSP075002GU G
2.5 12	21.5 31	53 47	19 32	12.5	0.05~0.10	0.20 0.91	KSP096002GU P KSP096002GU G
3.6 15	27.5 35.5	67 55	25 40	22.2	0.05~0.10	0.36 1.45	KSP119002GU P KSP119002GU G

Spur
Gears

Helical
Gears

Internal
Gears

Racks

CP Racks &
Pinions

Miter
Gears

Bevel
Gears

Screw
Gears

Worm
Gears

Gearboxes

Other
Products



Spur Gears

Helical Gears

Internal Gears

Racks

CP Racks & Pinions

Miter Gears

Bevel Gears

Screw Gears

Worm Gears

Gearboxes

Other Products

Adjustment of tooth contact

<Center of tooth contact>

- (1) Near the center of the tooth length for the length direction
- (2) Ideally, the tooth width direction should be at the center of the width or slightly closer to the toe.

When adjusting the backlash and mounting the gear in the case, adjust the case in order to achieve the tooth contact as shown in the figure below.

Deviation of the tooth contact from the normal position may adversely affect the strength and quietness.

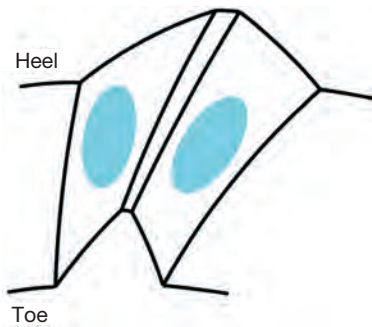

(1) Tooth contact in case of a shaft-angle error

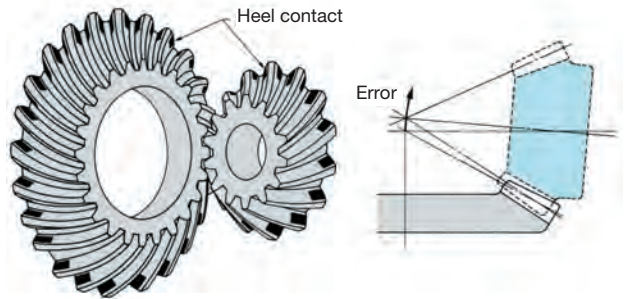
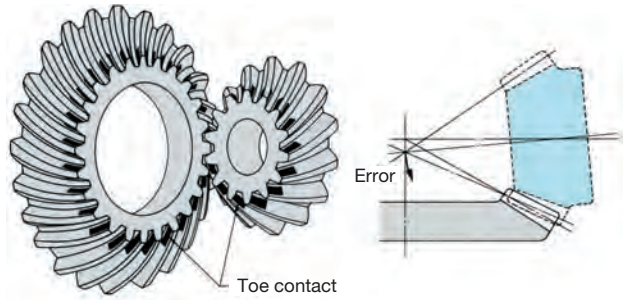

(2) Tooth contact in case of a shaft-offset error

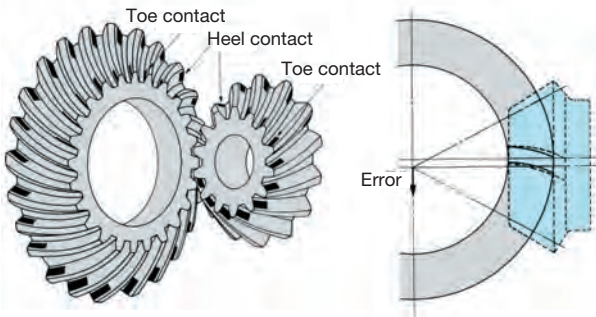
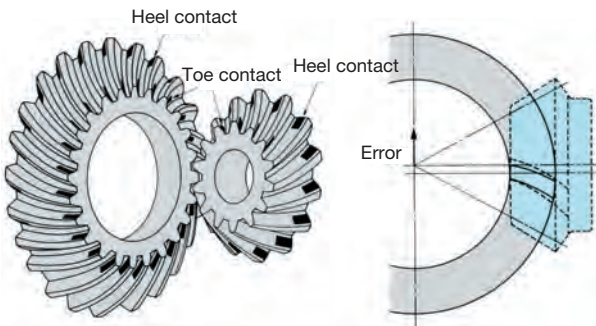

(3) Tooth contact in case of a pinion set position error

