

KHK

The ABC's of Gears

Basic Guide - B



The world's first EMT Bicycle by SHIBUO (includes KHK stainless gears)

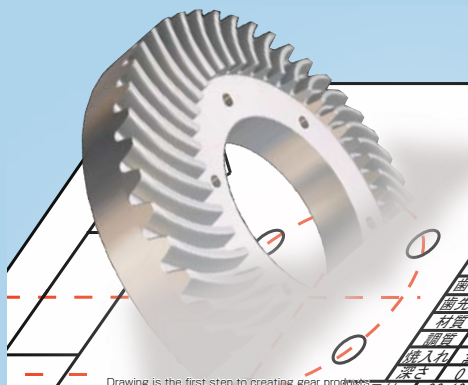

Drawing is the first step to creating gear profiles

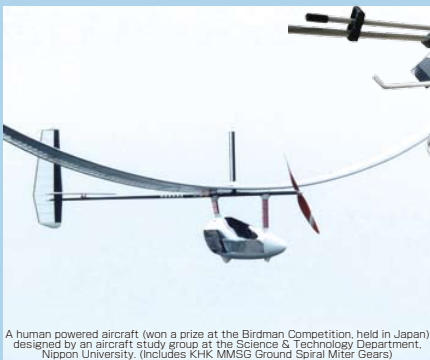

A human powered aircraft (won a prize at the Birdman Competition, held in Japan) designed by an aircraft study group at the Science & Technology Department, Nippon University. (Includes KHK MMSG Ground Spiral Miter Gears)

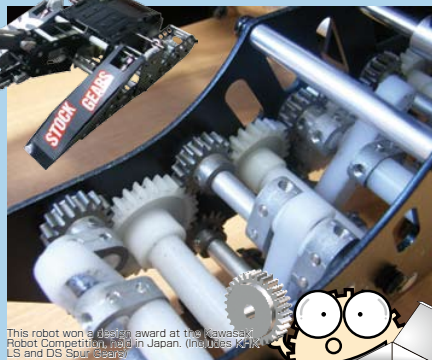

This robot won 1st place award at the Kawasaki Robot Competition held in Japan. (Includes KHK LS and DS Spur Gears)



KOHARA GEAR INDUSTRY CO., LTD.

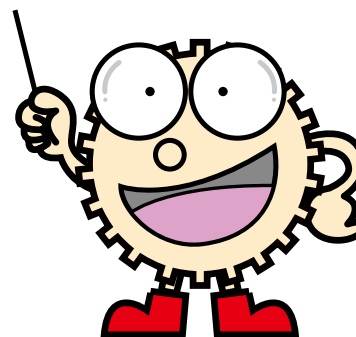

Hello, I am Haguruma Boy!
Did you find the Introductory Guide - A useful? I hope it helped you learn about the history of gears and their usages.

The ABC's of Gears include 3 editions; Introductory Guide, Basic Guide, and Guide for Practical Use.

This 'Basic Guide - B' introduces; Types of Gears, How to Use Gears, Basic Calculations for Gears, Tooth Profiles, Shifting, Accuracies, and Strength of Gears.

To learn more about Gears, please refer to the following, "Guide for Practical Use - C" .

Contents

1. Gear Types and Characteristics	P 2
1-1 Parallel Axis Gears	P 4
1-2 Linear Motion Gears	P 7
1-3 Intersecting Axis Gears	P 8
1-4 Nonparallel and Nonintersecting Axis Gears	P10
2. Basic Terminologies and Calculations	P12
3. Gear Tooth Profiles	P20
4. Profile Shifting	P22
5. Gear Accuracy	P24
6. Gear Materials and Heat Treatments	P26
6-1 Gear Materials	P26
6-2 Heat Treatments	P27
7. Strength and Durability of Gears	P28
8. Surface Treatment of Gears	P30
9. Manufacturing of Gears	P32
9-1 Manufacturing Process of Spur Gears	P32
9-2 Manufacturing Process of Racks	P33
9-3 Manufacturing Process of Bevel Gears	P34
9-4 Manufacturing Process of Worms	P35

1. Gear Types and Characteristics

In the following pages we present three general gear categories corresponding to KHK Stock Gear Classifications.

Categories of Gears	Types of Gears	Efficiency (%)	Isometrics
Parallel Axis Gears 	Spur Gear	98.0-99.5	
	Helical Gear		
	Rack · Helical Rack		
	Internal Gear		
Intersecting Axis Gears 	Miter Gear	98.0-99.0	
	Straight Bevel Gear		
	Spiral Bevel Gear		
Nonparallel and Nonintersecting Axis Gears 	Screw Gear (Crossed Helical Gear)	70.0-95.0	
	Worm	30.0-90.0	
	Worm Wheel		

There are so many types of gears.

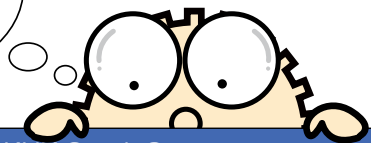

KHK Stock Gears				
MSGA 	SSG 	SS 	SUS 	PS
KHG 	SH 			
KRG (F) (D) 	SRFD 	SUR (F) (D) 	PR (F) 	KRHG (F)
SI 	SIR 			
MMSG 	SMSG 	MM 	SUM 	PM
SB · SBY 	SB 	SUB 	PB 	DB
MBSG 	SBSG 	MBSA (B) 	SBS 	
SN 	SUN 	AN 	PN 	
KWGD (S) & AGDL 	KWG & AGF 	SWG & AG 	SW & BG · CG 	SUW & PG

Gear types are classified into 3 categories, generally by the directions of the mounting shafts. Here, in this section, we introduce the characteristics of gears, how to use gears, and technical tips (hints).

1 – 1 Parallel Axes Gears



Gears involving two axis, which are parallel to each other, are called Parallel Axis Gears. For the transmission of rotation/power by parallel axis, Spur, Helical and Internal Gears are generally used. These are the most commonly used gears, with a wide range of applications, in various industries.

Spur Gear



A spur gear is a cylindrical shaped gear, in which the teeth are parallel to the axis. It is the most commonly used gear with a wide range of applications and is the easiest to manufacture.

Characteristics / Technical Hints

- A gear which is the most easiest to manufacture.
- A gear that is easy to use and does not produce axial thrust forces.
- There is no limit in the combination of the number of gear teeth of paired gears.

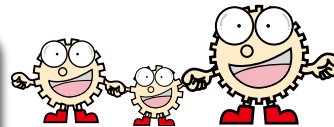

Speed Ratio

In Figure.1.1, a pair of meshed gears in single-stage gear train. As you can see, the rotational direction of the paired gears is opposite to each other. If Gear 1 rotates clockwise, then Gear 2 rotates counterclockwise. Also, if paired gears have a different number of teeth, the speed will be increased / decreased; If Gear 1 is a drive gear, speed is reduced. If Gear 2 is a drive gear, speed is increased.

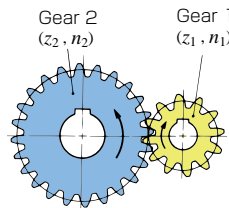

Fig.1.1 Spur Gear

$$\text{Speed Ratio} = \frac{\text{No. of teeth of driven gear } (z_2)}{\text{No. of teeth of drive gear } (z_1)} = \frac{\text{Rotation of drive gear } (n_1)}{\text{Rotation of driven gear } (n_2)} \quad (1.1)$$



Calculation Example

No. of teeth of drive Gear1 : 20
 Rotation of gear : 400rpm
 No. of teeth of driven Gear2 : 80, Single-stage gear train.
 The Speed ratio of this gear train : $80 \div 20 = 4$
 The rotation of Gear2 : $400 \div 4 = 100\text{rpm}$

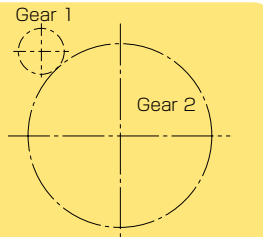

Helical Gear



The spur gear that has helix teeth (helicoids teeth) is called Helical Gear. Helical gears can bear load more than spur gears and work more quietly. They are also widely used in different industries, such as the automotive, and in industrial machinery.

Characteristics and Technical Hints

- More strength than the spur gear of the same size; transmits rotational force / power quietly.
- Suitable for use in high speed rotations.
- Produces axial thrust force, need to cope with these extra forces
- There is no limit in the combination of number of gear teeth of paired gears.

The direction of the rotation and the thrust force in meshed helical gears are illustrated in the Figure 1.2. Thrust bearing receives thrust force. The direction of the rotation is the same as meshed spur gears.

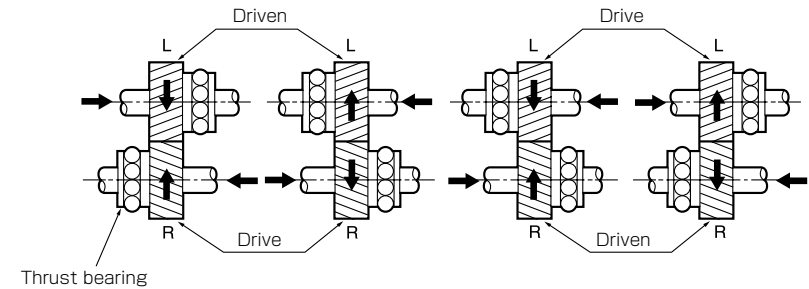

Fig.1.2 Direction of Rotation and Thrust Force

A paired gear rotates in opposite direction each other. The speed ratio is the same as it for spur gears.

Speed Ratio of Two-Stage Gear Trains

If Gear 1 is a drive gear, the speed ratio (i) for this two-stage gear train is calculated as below.

$$i = \frac{z_2}{z_1} \times \frac{z_4}{z_3} = \frac{n_1}{n_2} \times \frac{n_3}{n_4} \quad (1.2)$$

Gear 1 and Gear 4 rotate in the same direction. Number of teeth of Gear 1/2/3/4 is 10/24/12/30, respectively, then, the reduction ratio for this gear train is 6.

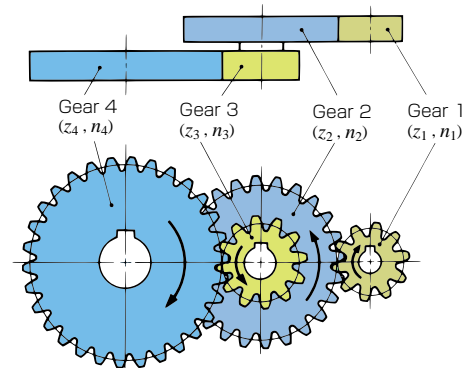

Fig.1.3 Two-Stage Gear Train

Internal Gears

This is a cylindrical shaped gear, but with teeth inside the circular ring, and can mesh with a spur gear. Internal gears are often used in Planetary Gear Systems, or Gear Couplings.



Characteristics / Technical Hints

- Involves more complexity in manufacturing compared, to spur gears.
- By using planetary gear systems, it enables you to create a compact gear system applicable for high reduction ratio.
- For a pair of internal and external gears meshed, the following 3 interferences might occur: (a) Involute Interference (b) Trochoid Interference and (c) Trimming Interference
- No limit to the combination of the number of gear teeth, of paired gears.

Speed Ratio

In the simplest example of a meshing External Gear 1 (Pinion) with an Internal Gear 2, both the External Gear 1 and Internal Gear 2 rotate in the same direction, as shown in Fig. 1.4

$$\text{Speed Ratio} = \frac{\text{No. of teeth of Driven Gear}}{\text{No. of teeth of Drive Gear}} \quad (1.3)$$

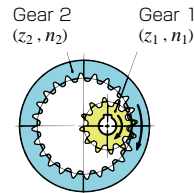

Fig. 1.4 Spur Gear and Internal Gear

Planetary Gear Systems

Planetary Gear System consists of 4 major elements: Sun Gear (A), Planet Gear (B), Internal Gear (C), and Carrier (D)

In the system shown in Fig. 1.5, 4 planet gears are used. The load division shared by many gears enables a compact system. The speed ratio or the direction of rotation in the Planet Gear System differs, depending on what factor is fixed.

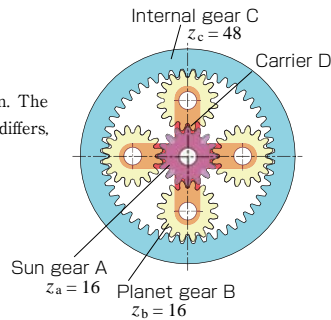

Fig. 1.5 Example of a planetary gear system

(a) Planetary Type

If the Sun gear is of input, and the Carrier gear is of output, and the Internal gear is fixed;

$$\text{Speed Ratio} = \frac{z_c}{z_a} + 1 \quad (1.4)$$

(b) Solar Type

Sun Gear is fixed.

(c) Star Type

Carrier Gear is fixed.

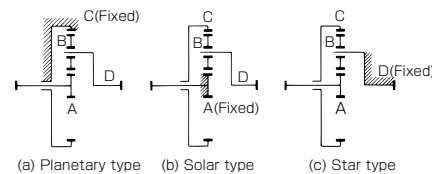

Fig. 1.6 Planetary Gear Mechanism

1 - 2 Gears with Linear Motion



Gears with Linear Motion are classified as Parallel Axis Gears, but there are specific types of "Linear Motion" that involve no mating shafts. To convert rotational movement to linear motion, or the converse, Racks and Pinions are used in combination. Cylindrical shaped gears with an infinite radius are called Racks, generally used in conveyors.

Spur Rack

This is a linear shaped gear, which has a straight-line tooth profile and can mesh with a spur gear. The spur rack can be regarded as a portion of a spur gear with an infinite radius, and several racks can be combined in a line.



Characteristics / Technical Hints

- Easier to manufacture and to use than Helical Racks.
- Can mesh with a spur gear with any number of teeth.

In regards to a meshed rack and pinion, the movement distance when the pinion rotates one time, is calculated from the number of teeth multiplied by the pitch. Pitch denotes the distance between corresponding points on adjacent teeth. CP racks are designed for easy positioning. (Figure 1.7)

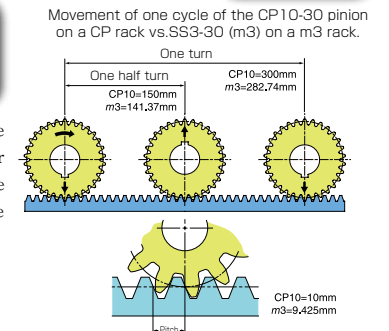

Fig. 1.7 Difference between CP10 and m3

Helical Rack

This is a linear shaped gear that meshes with a helical gear. A Helical Rack can be regarded as a portion of a helical gear with infinite radius.

Characteristics / Technical Hints

- Produces thrust force; coping mechanism must be considered
- Rotates and transmits power more quietly than a helical rack of the same size
- Suitable for use in high speed rotation
- Can mesh with a helical gear with any number of teeth

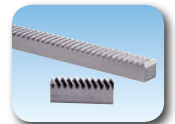

It produces thrust force due to the gear-tooth helix. The Figure 1.8 shows the direction of rotation and the thrust force.

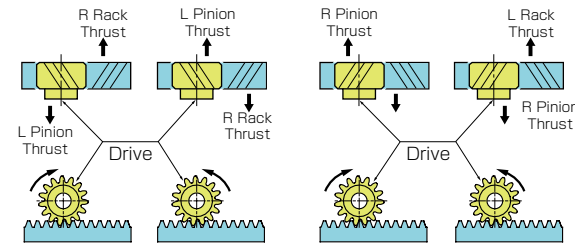

Fig. 1.8 Direction of Rotation and Thrust Force

1 – 3 Intersecting Axis Gears



Gears involving two axis crossing at a point are called Intersecting Axis Gears; general applications include rotation / power transmission of Bevel gears. Bevel Gears with gear ratio of 1, are called Miter gears. Bevel Gears are classified as Straight-Bevel Gears or Spiral-Bevel Gears, depending on the tooth form.

Straight Bevel Gear

This is a gear in which the teeth have tapered conical elements that have the same direction as the pitch cone base line (generatrix). The straight bevel gear is both the simplest to produce and the most widely applied in the bevel gear family.



Characteristics / Technical Hints

- Easier to manufacture than Spiral Bevel Gears.
- Ease of use, produces no thrust force in the negative direction.
- The combination of the No. of teeth of paired gears is important. Those gears produced in combination do not mesh with other bevel gears.

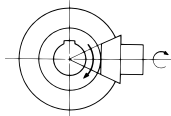

Fig. 1.9 Direction of Rotation

Spiral Bevel Gear

A bevel gear that has spiral teeth with a helical angle, which is more complex to manufacture, but offers advantages of higher strength and less noise.



Characteristics / Technical Hints

- Suitable for use in high load / rotation. Better than Straight Bevel Gears
- Axial thrust force should be carefully considered
- Transmits rotational force / power more quietly than Straight Bevel Gears.
- Since these gears are produced as a pair, in accordance with the number of teeth, they do not mesh with other gears, even if they have the same modules or pressure angles.

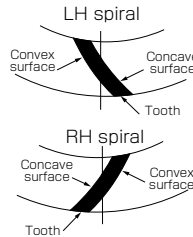

Fig. 1.10 Contact Surface of Spiral Bevel Gears

Speed Ratio

$$\text{Speed Ratio} = \frac{\text{No. of teeth of Driven Gear}}{\text{No. of teeth of Drive Gear}} \quad (1.5)$$

Thrust force on Spiral Bevel Gear

The figure on the right shows the rotational direction and thrust force for the mesh of spiral bevel gears, with gear ratio more than 1.57. If the pinion meshes with a convex tooth-face, it produces thrust force in the negative direction.

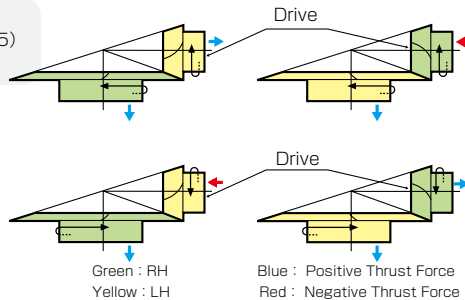

Fig.1.11 Direction of Rotation and Thrust Force

Straight & Spiral Miter Gear

Gears which are used as a pair, with the same number of teeth, are called Miter Gears. There are two types of miter gears; a miter gear of straight bevel gears, and the other is a miter gear of spiral bevel gears. Generally, they have a shaft angle of 90 degrees, however, KHK offers standardized angular miter gears with the shaft angle at 45, 60, and 120 degrees.



Characteristics / Technical Hints

- Bevel gears with the gear ratio at 1 is deemed a Miter Gear
- Used for changing rotational or axial directions

Thrust Force on Spiral Miter Gears

The Figure 1.12 shows the rotational direction and the thrust force on spiral miter gears. In case they produce thrust force in a negative direction as well as in a positive direction, the bearings must be positioned carefully so they can receive the forces evenly.

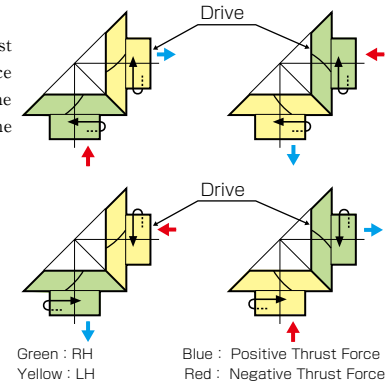

Fig. 1.12 Direction of Rotation and Thrust Force

Angular Miter Gears and Miter Gears

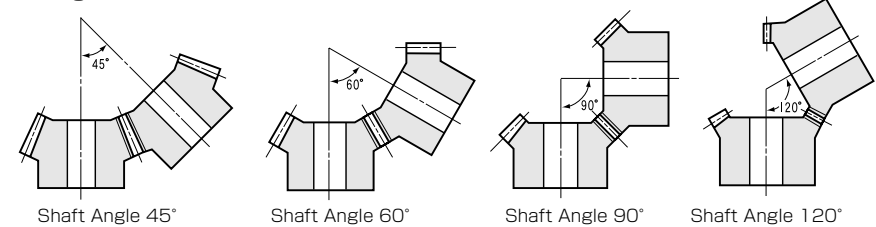

Fig. 1.13 Shaft Angles of KHK Stock Gears

1 – 4 Nonparallel and Nonintersecting Gears



Gears involving two axis, which are not intersected or parallel, are called Nonparallel and Nonintersecting Axis Gears. They are generally used as worm gear pairs or screw gears. These gears transmit rotational force/power by the relative slippage between gear-tooth surfaces.

Screw Gear (Crossed Helical Gear)

This is a helical gear with a spiral angle at 45 degrees. A pair of gears, nonparallel and are nonintersecting and have the same helix hands, are called screw gears. They work very quietly, but, can only be used for light loads.



Characteristics / Technical Hints

- Care should be taken for lubrication. The slippage of the meshed faces transmits rotational force / power. Lack of proper lubrication may cause rapid wear.
- Efficiency is low when compared to parallel axis / intersecting axis gears.
- Used in low power transmission
- There is no limits to the no. of teeth of paired gears. (differing from Bevel Gears)

The direction of rotation and thrust force on right-helical (R) / left-helical (L) combinations are shown in the Figure 1.14.

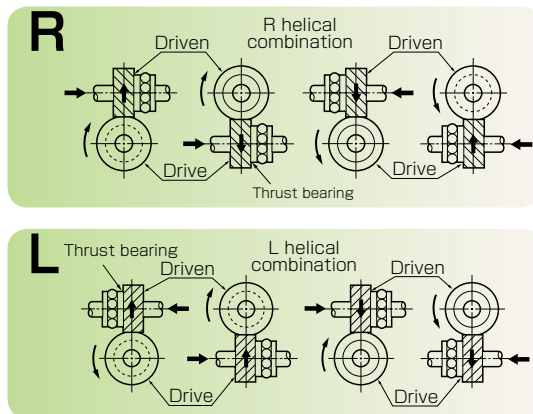

Fig.1.14 Direction of Rotation and Thrust Force

Speed Ratio

This formula for the speed ratio is the same as it for spur gears.

$$\text{Speed Ratio} = \frac{\text{No. of teeth of Driven Gear}}{\text{No. of teeth of Drive Gear}} \quad (1.6)$$

Worm Gear Pair



A Worm Gear pair is a set of gears, where one gear is a worm having screw threads and the other is a meshed worm wheel. Worm gear pairs are often used in power transmission with high-reduction or high-torque.

Speed Ratio

$$\text{Speed Ratio} = \frac{\text{No. of teeth of Worm Wheel}}{\text{Threads of Worm}} \quad (1.7)$$

The direction of rotation and thrust forces on right-helical (R) / left-helical (L) worm mesh, are shown in Figure 1.15.

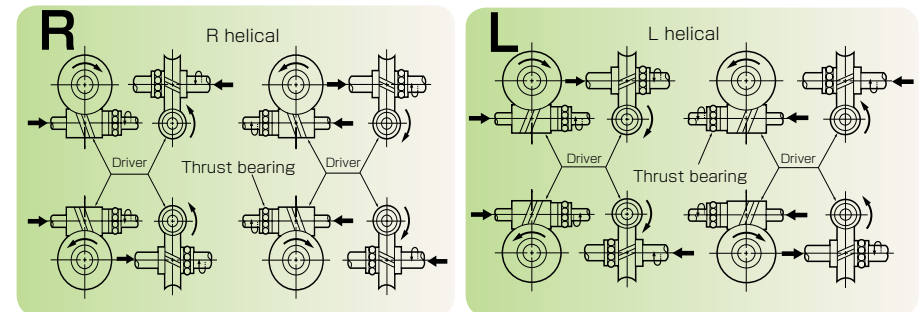

Fig.1.15 Direction of Rotation and Thrust Forces

Characteristics / Technical Hints

- Large reduction ratio can be obtained by a single-stage train
- Efficiency is low if compared with parallel-axis gears or intersecting-axis gears
- Worm gear pairs must be designed and produced as a pair. Gear-cutting is applied by a selective cutting machine in accordance with the base diameter of the meshing worm.
- As with screw gears, slippage occurs on the tooth surface of gears in mesh. Care should be taken for lubrication. Lack of proper lubrication may cause rapid wear.



Calculation Example

Threads of the worm $z_1 = 2$, No. of teeth of the worm wheel $z_2 = 40$

$$\text{Speed Ratio} = \frac{40}{2} = 20$$

2. Basic Gear Terminology and Calculations

Let's learn the basics of Basic Gear Technology!

Gear size, pressure angle, number of teeth...we introduce the basic terminology, measurement, and relational expressions necessary to understand basic gear technology.

Comparative Size of Gear-Teeth

Using ISO (International Organization for Standardization) guidelines, Module Size is designated as the unit representing gear tooth-sizes. However, other methods are used too.

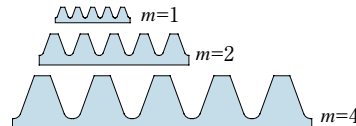

Fig.2.1 Tooth Profiles of Racks

Module (m)

$$m = 1 \quad (p = 3.1416)$$

$$m = 2 \quad (p = 6.2832)$$

$$m = 4 \quad (p = 12.566)$$

If you multiply Module by Pi, you can obtain Pitch (p). Pitch is the distance between corresponding points on adjacent teeth.

$$p = \text{Pi} \times \text{Module} = \pi m \quad (2.1)$$

Calculation Example



What is the pitch size (p) of the Gear with module m = 3 ?

$$p = \pi m = 9.4248$$

CP (Circular Pitch)

Circular Pitch (CP) denotes the reference pitch (p).

For instance, you can produce gears at an exact integral value, such as CP5/CP10/CP15/CP20.

Transformation from CP to Module

$$m = \frac{CP}{\pi} \quad (2.2)$$

Calculation Example



CP10 is transformed to module as follows;

$$m = \frac{10}{3.1416} = 3.1831$$

DP (Diametral Pitch)

DP stands for Diametral Pitch.

By ISO standards, the unit Millimeter (mm) is designated to express length, however, the unit inch is used in the USA, the UK and other countries; Diametral Pitch is also used in these countries

$$\text{Transformation from DP to Module} \quad m = \frac{25.4}{DP} \quad (2.3)$$



Calculation Example

DP 8 is transformed to module as follows;

$$m = \frac{25.4}{8} = 3.175$$

Pressure Angle (α)

Pressure angle is the leaning angle of a gear tooth, an element determining the tooth profile.

Recently, the pressure angle (α) is usually set to 20°, however, 14.5° gears were prevalent.

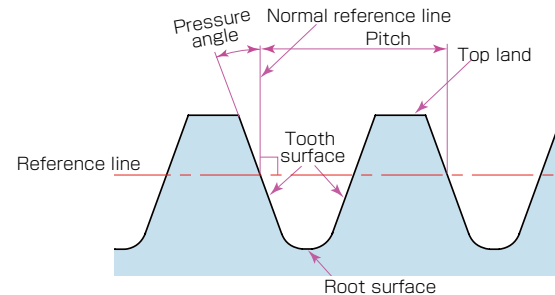

Fig.2.2 Normalized Tooth Profile of Reference

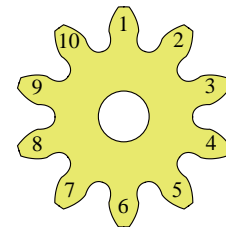
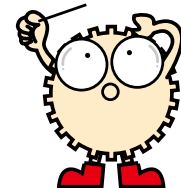

Fig. 2.3 No. of teeth

No. of teeth

No. of teeth denotes the number of gear teeth.

They are counted as shown in the Figure 2.3. The number of teeth of this gear is 10.

Module (m), Pressure Angle (α), and the No. of Teeth, introduced here, are the three basic elements in the composition of a gear. Dimensions of gears are calculated based on these elements.

■ Tooth Depth and Thickness

Tooth depth is determined from the size of the module (m). Introduced here are Tooth Profiles (Full depth) specified by ISO and JIS (Japan Industrial Standards) standards.

Please see Figure 2.4 below for explanations for Tooth depth (h) / Addendum (h_a) / Dedendum (h_f).

Tooth depth (h) is the distance between tooth tip and the tooth root.

$$h = 2.25 m \quad (2.4)$$

(= Addendum + Dedendum)

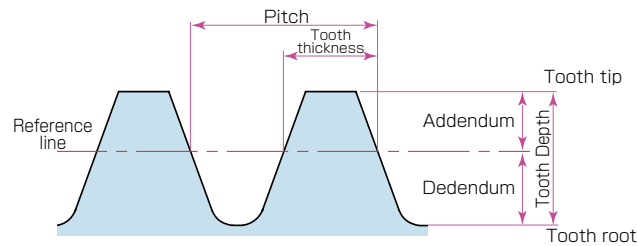

Fig. 2.4 Tooth Depth and Thickness

Addendum (h_a) is the distance between the reference line and the tooth tip.

$$h_a = 1.00 m \quad (2.5)$$

Dedendum (h_f) is the distance between the reference line and the tooth root.

$$h_f = 1.25 m \quad (2.6)$$

Tooth thickness (s) is basically half the value of pitch (p). * Pitch (p) = πm

$$s = \frac{\pi m}{2} \quad (2.7)$$

Calculation Examples



The following are calculations of Tooth depth (h) / Addendum (h_a) / Dedendum (h_f) for a gear with module 2.

$$h = 2.25 m = 2.25 \times 2 = 4.50$$

$$h_a = 1.00 m = 1.00 \times 2 = 2.00$$

$$h_f = 1.25 m = 1.25 \times 2 = 2.50$$

In the previous pages, we introduced the basics of gears, including 'Module', 'Pressure Angle', 'Number of Teeth' and 'Tooth Depth and Thickness'. In this section we introduce the basic parts of Spur Gears (Cylindrical gears) and dimensional calculations.

■ Diameter of Gears (Size)

The size of gears is determined in accordance with the reference diameter (d) and determined by these other factors; the base circle, Pitch, Tooth Thickness, Tooth Depth, Addendum and Dedendum.

Reference diameter (d)

$$d = z m \quad (2.8)$$

Tip diameter (d_a)

$$d_a = d + 2 m \quad (2.9)$$

Root diameter (d_f)

$$d_f = d - 2.5 m \quad (2.10)$$

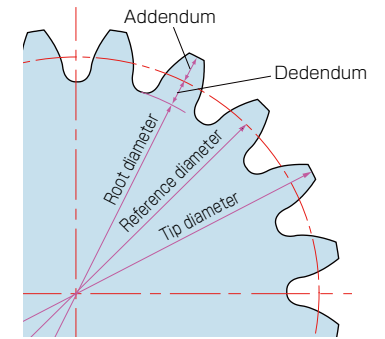

Fig.2.5 Diameter of Gears

☆ The Addendum and dedendum circle introduced here are a reference circle that cannot be seen on a gear, as it is a virtual circle, determined by gear size.



Calculation Examples

The following are calculations of Reference diameter / Tip diameter /

Root diameter for a spur gear with module(m) 2, and 20 teeth(z).

$$d = z m = 20 \times 2 = 40$$

$$d_a = d + 2 m = 40 + 4 = 44$$

$$d_f = d - 2.5 m = 40 - 5 = 35$$



Practice Test

Spur Gear Specifications

Module (m) = 4 No. of teeth (z) = 40 (Pressure angle $\alpha = 20^\circ$)

Reference diameter $d =$

Tip diameter $d_a =$

Root diameter $d_f =$



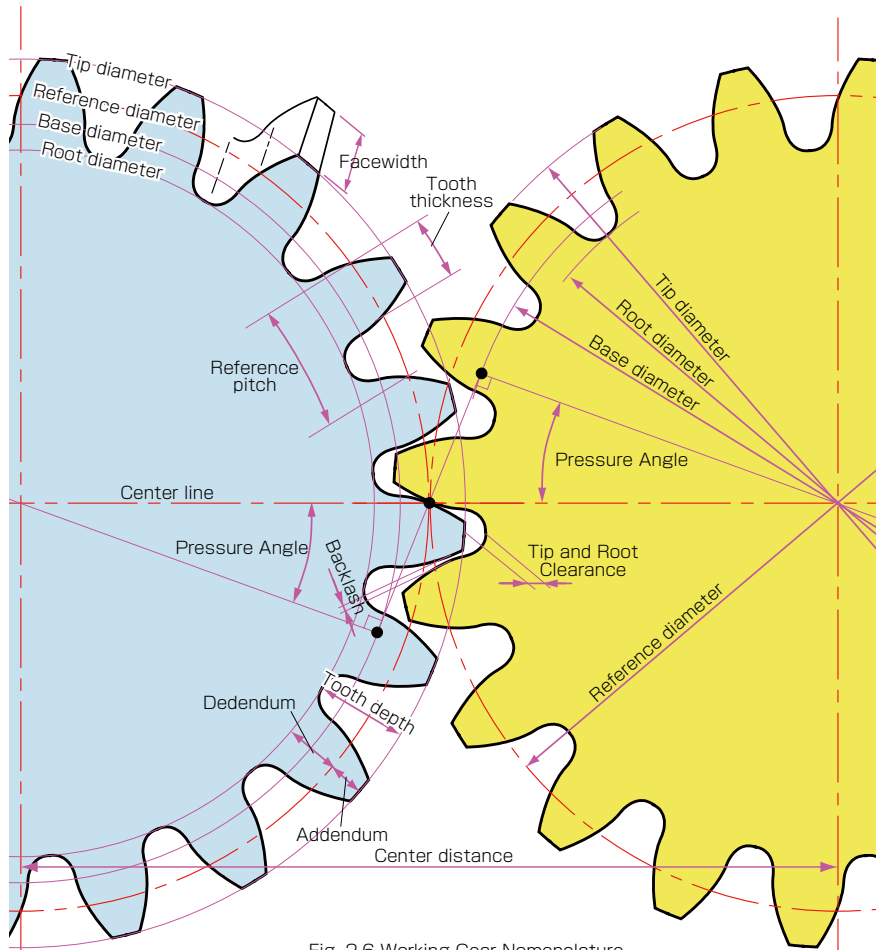

Fig. 2.6 Working Gear Nomenclature

Table 2.1 Gear Symbols and Nomenclature

Terms	Symbols	Terms	Symbols
Module	m	Tooth Thickness	s
Pressure Angle	α	Reference Diameter	d
No. of Tooth	z	Tip Diameter	d_a
Pitch	p	Root Diameter	d_f
Tooth Depth	h	Center Distance	a
Addendum	h_a	Backlash	j
Dedendum	h_f	Tip and Root Clearance	c

Center Distance and Backlash

When a pair of gears are meshed so that their reference circles are in contact, the center distance (a) is half the sum total of their reference diameters.

Center distance (a)

$$a = \frac{(d_1 + d_2)}{2} \quad (2.11)$$

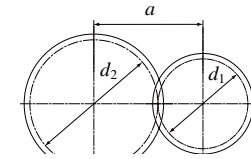

Fig. 2.7 Center distance

Gears can mesh as shown in the Figure 2.6, however, it is important to consider a proper backlash (play) so that the gears can work smoothly. Backlash is a play between tooth surfaces of paired gears in mesh.

Mating gears also have a clearance (play) vertical to tooth depth. This is called Tip and Root Clearance (c), the distance between tooth root and the tooth tip of mating gears.

Tip and Root Clearance (c)

$$c = 1.25 m - 1.00 m = 0.25 m \quad (2.12)$$

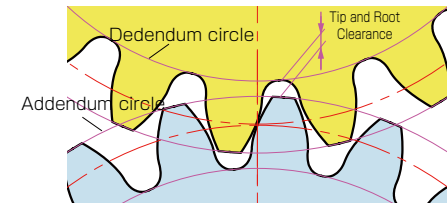

Fig. 2.8 Tip and Root Clearance



Calculation Examples

The following are calculations for Center distance (a) and Tip and root clearance(c)

when ; Module $m = 2$, Pinion $z_1 = 20$, Gear $z_2 = 40$

Reference diameter of Pinion $d_1 = 20 \times 2 = 40$

Reference diameter of Gear $d_2 = 40 \times 2 = 80$

$$\text{Center distance } a = \frac{(40 + 80)}{2} = 60$$

$$c = 0.25 \times 2 = 0.5$$



Calculation Examples

Practice calculating the dimensions of gears.

Terms	Symbols	Formula	Pinion	Gear
Module	m	X	2.5	
Pressure Angle	α		20°	
No. of Teeth	z		15	30
Reference diameter	d	$z m$	37.5	75
Addendum	h_a	$1.00 m$	2.5	2.5
Dedendum	h_f	$1.25 m$	3.125	3.125
Tooth Depth	h	$2.25 m$	5.625	5.625
Tip diameter	d_a	$d + 2 m$	42.5	80
Root diameter	d_f	$d - 2.5 m$	31.25	68.75
Center distance	a	$\frac{d_1 + d_2}{2}$	56.25	

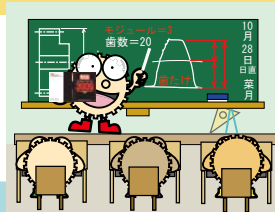

Practice Test

Calculations for the dimensions of gears.

Terms	Symbols	Formula	Pinion	Gear
Module	m	X	4	
Pressure Angle	α		20°	
No. of Teeth	z		12	60
Reference diameter	d	$z m$		
Addendum	h_a	$1.00 m$		
Dedendum	h_f	$1.25 m$		
Tooth Depth	h	$2.25 m$		
Tip diameter	d_a	$d + 2 m$		
Root diameter	d_f	$d - 2.5 m$		
Center distance	a	$\frac{d_1 + d_2}{2}$		

Helical Gear

Spur gears with helicoid teeth are called Helical Gears.

The majority of calculations for spur gears can be applied to helical gears too. This type of gear comes with two kinds of tooth profiles in accordance with the datum surface. (Figure 2.9)

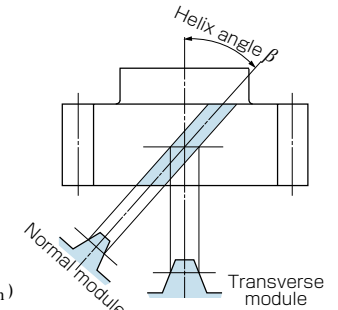

Fig. 2.9 Right-handed Helical Gear

(a) Transverse System (Transverse module / Pressure angle) NOTE 1

(b) Normal System (Normal module / Pressure angle)

NOTE 1. Transverse axis denotes the centerline of the gear.

Relational Expression: Transverse module(m_t) and Normal module(m_n)

$$m_t = \frac{m_n}{\cos \beta} \quad (2.13)$$

Both systems are used in KHK Stock Gears.

Transverse System : KHG Grounding helical gears

Normal System : SH Helical gears

Reference diameter (d) of the helical gear with transverse system can be calculated from Equation (2.8).

Reference diameter (d) of the helical gear with normal system can be calculated from Equation (2.14).

$$d = \frac{z m_n}{\cos \beta} \quad (2.14)$$



Calculation Examples

The following is a calculation for the Reference Diameter of a helical gear with;

Transverse module $m_t = 2$, No. of teeth $z = 30$, Helix angle $\beta = 15^\circ$ (R)

Reference Diameter $d = z m_t = 30 \times 2 = 60$

The following is a calculation for the Reference Diameter of a helical gear with;

Normal module $m_n = 2$, No. of teeth $z = 30$, Helix angle $\beta = 15^\circ$ (R)

Reference Diameter $d = z m_n / \cos \beta = 30 \times 2 / \cos 15^\circ = 62.117$



Practice Test

Specifications for a helical gear

Normal module (m_n) = 4 Helix angle (β) = 15°

Transverse module $m_t =$

3. Gear Tooth Profiles

One of the most popular tooth profiles is the Involute Tooth Profile.

The majority of gears used in industrial machinery are gears with an involute tooth profile. The popularity of the involute tooth profile is derived from many of its advantages, such as simplicity in design and ease of use.

Characteristics of Involute Tooth Profiles

1. Easy machining for production (Straight rack tooth profile)
2. Rotation is smooth despite changes occurring in the center distance.
3. Gears with different number of teeth can be modified by machining if they have the same module and the pressure angle.

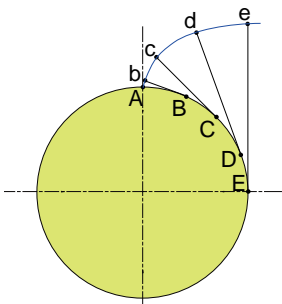

Fig. 3.1 Involute Curve

What is an involute Tooth Profile?

Involute tooth profile (Involute curve) is a curve made by a base circle (d_b). The definition of an involute is the spiraling curve traced by the end of an imaginary taut string unwinding itself from that stationary circle called the base circle. The resultant is the Involute curve A - b - c - d - e, and so on.

Figure 3.1 shows the state of the curve when the straight line is rolled down by 90 degrees (1/4 of the circle).

What is Base Circle?

The base circle is the base circle of the involute, and its value is determined depending on the sizes of the pressure angle (α) and the reference circle (d).

$$d_b = d \cos \alpha \quad (3.1)$$

The Base circle is also the base circle of the involutes.

The Reference circle is the actual reference that determines the size of the gear.

Dimensions of both the base circle / reference circle are crucial for gearing.

An Involute tooth profile is the curving line created external to the side of the base circle.

The value of the pressure angle becomes 0 (zero) on the base circle.

Meshing of Involute Gear

A pair of standard involute gears mesh together between the reference Center Distance, making contact at a point on the reference circle of each other.

This state resembles friction wheels with reference diameter's, d_1 and d_2 . However, involute gears actually mesh based on the base circle, instead of the reference circle, resembling a rotation/power transmission by using a cross-coupled belt placed around the 2 base circles.

In case of a belt drive, slippage tends to occur when frictional force gets smaller than power transmission. However, in case of gears, they can transmit rotation/power without slippage as they have teeth.

The common tangent of the two base circles (A and B) is called the line of contact, or line of action. The contact point $P_1 \rightarrow P_2 \rightarrow P_3$ of the two involutes slide along the common tangent of these two base circles.

Look at the yellow teeth of the drive gear in the figure on the right, after the tooth begins to mesh, two of the teeth are kept in mesh (P_1/P_3). Then, when the contact point on the two base circles moves to point P_2 , it meshes with one more tooth. With further movement of the drive gear, the contact point moves to P_3 and the next tooth P_1 starts meshing, so two teeth mesh again. Therefore, the gear transmits rotation by meshing two teeth and one tooth, alternately and repeatedly.

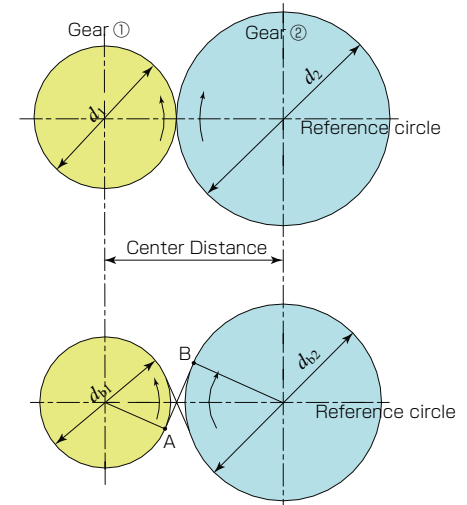

Fig. 3.2 Power Transmission

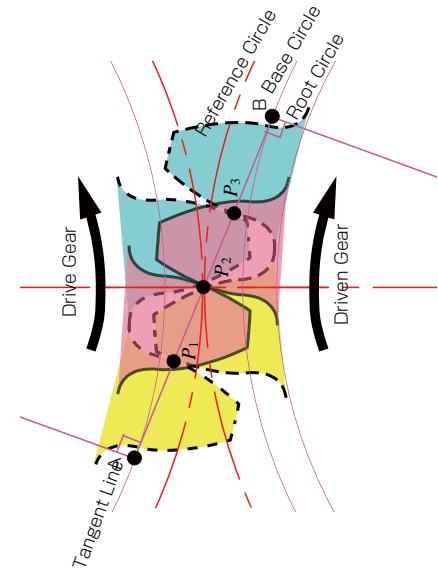

Fig. 3.3 Meshing of Involute Gear

4. Profile Shifting

Usage of profile-shifted gears enables more strength, by adjusting the center distance.

When you use gears, you might find a situation that you need to adjust the center distance to create more strength. In this section, we introduce profile shifting by changing tooth profile, or tooth thickness.

Gears are divided into two types, one is a standard gear, and the other is a profile-shifted gear. Standard gears have a basic tooth profile as shown in Figure 4.1. Profile shifting is applied to create gears with tooth thickness that is different from standard gears. By making the tooth thickness of involute gears thicker or thinner, you can change gear strength and the center distance of paired gears.

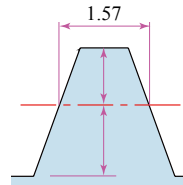

Fig. 4.1 Tooth profile of a rack with Module 1

Number of Teeth and Tooth Profiles

Although the tooth profile of racks is straight, the tooth profile of involute gears differs depending on the number of teeth. Involute tooth profile is curvilinear, but becomes straighter like the tooth profile of a rack, if the number of teeth is increased.

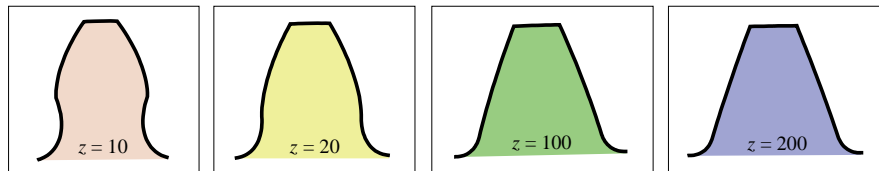

Fig. 4.2 Tooth profiles varied by number of teeth

When the number of teeth is increased, the tooth profile gets thicker at the tooth-root and can generate more strength. As for the tooth profile of a 10-teeth gear, it is gouged at the tooth-root and under-cutting occurs.

Small ← No. of Teeth → Large
 Small ← Tooth Thickness at Root → Large
 Small ← Strength → Large

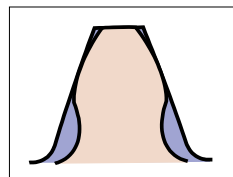

Fig. 4.3 Comparison of Tooth Profiles : z=10 x z=200

By applying a positive correction and increasing the tip diameter and thickness, 10-teeth gears can also obtain the strength of a 200-teeth gear (z=200).

Profile Shifted Gear

Figure 4.4 shows gear cutting for a positive correction of 10-teeth gear (z = 10). The amount of shift or correction made when applying gear cutting is called the extra feed of gear cutter xm (mm).

- xm = Extra feed of gear cutter (mm)
- x = Profile Shift Coefficient
- m = Module (mm)

As in Figure 4.5, if profile shifting (Profile Shift coefficient $x = +0.5$) is applied, the tooth profile is changed and the tooth thickness increases. Outside diameter (Tip diameter) also becomes larger. It is also notable that positive correction is effective to prevent undercut. There are also other reasons for applying profile shifting, stated below.

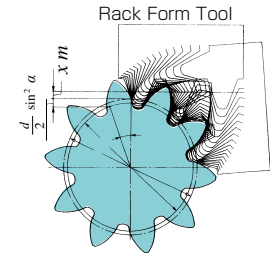

Fig. 4.4 Generation of Positive Shifted Spur Gear ($\alpha = 20^\circ, z = 10, x = +0.5$)

Changing the Center Distance

Reference center distance of the standard gear (without shifting) is the half value of the sum of reference diameters. Profile shifted gears allow you to enlarge or reduce the center distance. Positive correction → Enlarge the center distance
 Negative correction → Reduce the center distance

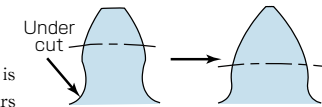

Fig. 4.5 Comparison with Positive Shifted Tooth Profile

Characteristics and technical hints for Profile Shifted Gears

There are limits in profile shifting, for both positive correction and negative correction.

Positive Correction

- Forms a tooth profile that has more bending strength, as the tooth thickness becomes thicker at the root.
- Contact ratio becomes smaller, as the working pressure angle becomes larger by the increase of the center distance.
- Tooth tip might be sharpen, more shifting is applied, the tooth width at the tip gets smaller, and the tooth tip becomes sharpen if it exceeds the limit in shifting.

Negative Correction

- Forms a tooth profile that has less bending strength, as the tooth thickness becomes thinner at the root.
- Contact ratio becomes larger, as the working pressure angle becomes smaller by the decrease of the center distance.
- Undercut may occur, more shifting is applied, the tooth width at root gets smaller, undercut occurs if it exceeds the limit in shifting.

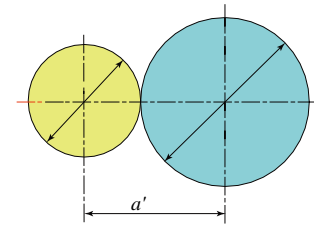

Fig. 4.6 Center Distance of Positive Shifted Gear

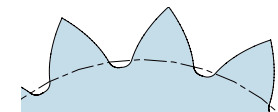

Fig. 4.7 Pointed Tooth-tips

5. Gear Accuracy

High accuracy in a gear denotes a gear that will produce less errors.

A gear must work in transmitting rotation/power from one gear axis to another, efficiently and quietly. To improve gear accuracy is to improve the performance of a gear.

- Gear accuracy can be loosely classified into 3 types
- The datum of gear accuracy is the centerline (gear axis) of a gear
- Higher accuracy gears have less errors

- (1) Precision in involute tooth profile → Profile Deviation
- (2) Precision in tooth face / tooth trace → Helix Deviation
- (3) Precision in positioning of teeth / tooth-spaces
 - Precision in tooth positioning → Single Pitch Deviation (Precision in pitch)
 - Variation of the position of a ball inserted in each tooth space, around the gear → Runout Error of Gear Teeth

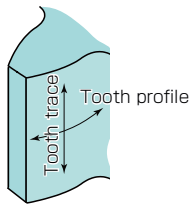
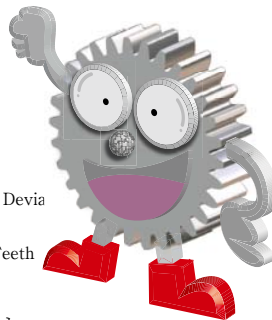
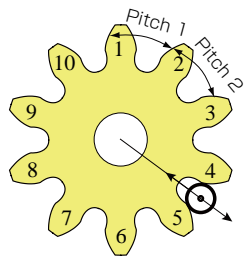

Fig. 5.1 Gear Accuracy



Profile Deviation (F_a)

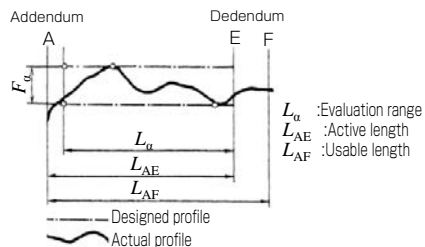

Fig. 5.2 Total Profile Deviation F_a

Helix Deviation (F_β)

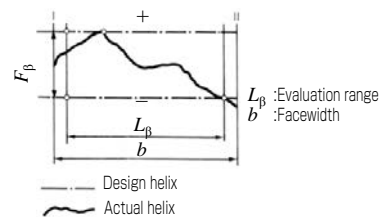

Fig. 5.3 Total helix deviation F_β

Pitch Deviation

The pitch value is measured on a measurement-circle where the center is the gear axis.

(a) Single Pitch Deviation (f_{pt})

The deviation between actual measurement pitch value and theoretical circular pitch.

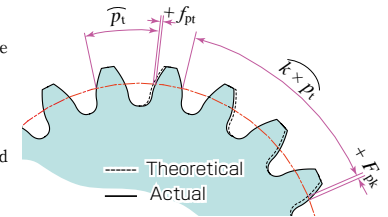

Fig. 5.4 Pitch Deviation

(b) Total Cumulative Pitch Deviation (F_p)

Evaluated by measuring the accumulative pitch deviation of the total amount of gear teeth, where the overall amplitude of accumulative pitch error curve is the total cumulative pitch deviation.

Runout Error of Gear Teeth (F_r)

Runout error is measured by indicating the position of a pin or ball inserted in each tooth space around the gear and taking the largest difference. The values of runout include eccentricity.

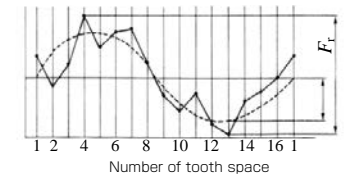

Fig. 5.5 Runout error of a 16-tooth gear

Total Radial Composite Deviation (F_i)

Tooth profile / Pitch / Tooth space are factors to evaluate gear accuracy by measuring a single gear. There is also another method to evaluate gear accuracy, which is the double flank meshing test method; a measurement of a gear meshed with the master gear. This method measures the variation in the center distance when the gear is rotated one revolution, in a tight mesh with a master gear.

Figure 5.6 is the test result for the 30-tooth gear. It shows 30 small mountain-like waves, representing the tooth-to-tooth radial composite deviation. The value of total radial composite deviation would be similar to the sum of runout error and tooth-to-tooth radial composite deviation.

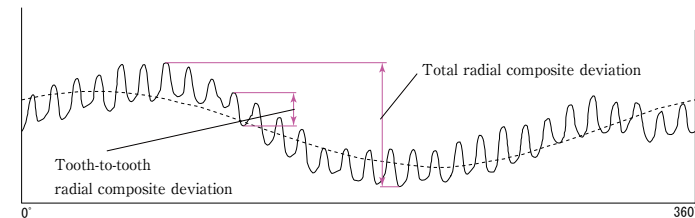

Fig 5.6 Test result of Total Radial Composite Deviation

6. Gear Materials and Heat Treatments

It is essential to select proper materials and heat treatments in accordance with the intended application of the gear.

Since gears are applied for various usages, such as industrial machinery, electric/electronic devices, household goods and toys, and composed of many kinds of materials, we like to introduce typical materials and their heat treatment methods.

6 - 1 Types of Gear Materials

■ S45C (Carbon Steel for Structural Machine Usage)

S45C is one of the most commonly used steel, containing moderate amounts of carbon (0.45%). S45C is easily obtainable and is used in the production of spur gears, helical gears, racks, bevel gears and worms.

Heat Treatment and Hardness

Heat Treatment	Hardness
None	less than 194HB
Thermal Refining	225 ~ 260HB
Induction Hardening	45 ~ 55HRC

■ SCM440 (Chrome-molybdenum Alloy Steel)

An alloy steel containing moderate amounts of carbon (0.40%). It also contains chrome / molybdenum. SCM440 has more strength than S45C and is used with thermal-refining or induction-hardening treatment for producing gears.

Heat Treatment and Hardness

Heat Treatment	Hardness
Thermal Refining	225 ~ 260HB
Induction Hardening	45 ~ 60HRC

■ SCM415 (Chrome-molybdenum Alloy Steel)

SCM415 is one of the most commonly used low-carbon alloy steel (C = 0.15%). Generally, it is carburized for use. It has more strength than S45C or SCM440. Surface hardness should be between 55 and 60HRC for use.

■ SUS303 (Stainless Steel : 18Cr-8Ni Stainless Steel)

Since it is called "stainless steel", it is a rust-resistant steel. This authentic stainless steel is basically non-magnetic. Most commonly used for gears in applications where rust contamination is undesirable, such as in food-processing machinery. There is a similar stainless steel called SUS304 which has more corrosion resistance than SUS303.

■ Copper Alloy Casting

Frequently used as a material for worm wheels. Phosphor bronze casting (CAC502) or aluminum-bronze casting (CAC702) are commonly used. For mating worms, iron metals such as S45C/SCM44/SCM415 are used. To prevent galling / seizure by slippage, different materials are used for each of the paired worm and worm wheel.

6 - 2 Heat Treatments

■ What is Quenching?

Quenching is a treatment performed on steel, applying rapid cooling after heating at high temperature (Approximate 800 C). Quenching is applied to adjust the hardness of steel. There are several types of quenching in accordance with cooling conditions; oil quenching, water quenching, and spray quenching. After quenching, tempering must be applied to give toughness back to the steel, that might become brittle. Quenching cannot harden genuine steel, however, quenching can work for steel containing more than 0.35% carbon.

■ What is Thermal Refining?

Thermal Refining is a heat treatment applied to adjust hardness / strength / toughness of steel. This treatment involves quenching and tempering. Since machining is applied to products after thermal refining, the hardness should not be raised too high in quenching.

■ What is Induction Hardening?

Induction Hardening is a heat treatment performed to harden the surface of the steel containing carbon more than 0.35%, such as S45C or SCM440. For gear products, induction hardening is effective to harden tooth areas including tooth surface and the tip, however, the root may not be hardened in some cases. The precision of gears declines by induction hardening. To encourage the gear accuracy, grinding must be applied.

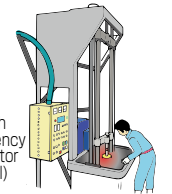

Fig. 6.1 Quenching Machine

■ What is Carburizing?

Carburizing is a heat treatment performed to harden only the surface of low-carbon steel. The surface, in which carbon is present and penetrated the surface, gets especially hardened. Inner material structure (with low-carbon C = 0.15%) is also hardened by some level of carburizing, however, it is not as hard as the surface. The precision of carburized gears declines by 1 grade or so, due to deformation (dimensional change) or distortion. To encourage the gear accuracy, grinding is essential.

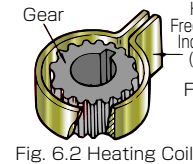

Fig. 6.2 Heating Coil

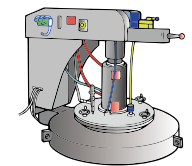

Fig. 6.3 Carburizing Furnace

■ What is Nitriding?

Nitriding is a heat treatment performed to harden the surface by introducing nitrogen into the surface of steel. If the steel alloy includes aluminum, chrome, and molybdenum, it enhances nitriding and hardness can be obtained. A representative nitride steel is SACM645 (Aluminum chromium molybdenum steel).



Fig. 6.4 Carbon layer by carburizing

7. Strength and Durability of Gears

The tooth is the most crucial element of gears. Strength of gears depends on the breakage durability or friction durability.

Gear designers decide specifications in accordance with factors like torque, rotation and expected lifetime. In this section, we briefly introduce the bending strength and the surface durability.

■ Bending Strength of Spur and Helical Gears JGMA401-01

As shown in the Figure.7.1, the tooth fillet breakage occurs at the root when applied force exceeds the limit. The following is the equation for bending stress:

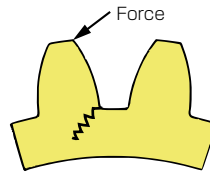

Fig. 7.1 Lack of bending stress at root

$$\text{Allowable Tangential Force } (F_{\text{lim}}) = \sigma_{\text{Flim}} \frac{m_n b}{Y_F Y_e Y_\beta} \left(\frac{K_L K_{\text{FX}}}{K_V K_O} \right) \frac{1}{S_F} \quad (7.1)$$

Symbol	Name	Affected Factors and other Specifications
σ_{Flim}	Allowable bending stress at root	Material / Heat treatment
m_n	Normal Module	Tooth size
b	Face Width	Gear size
Y_F	Tooth Profile Factor	Pressure angle/ Profile shift coefficient / Tooth width
Y_e	Load Sharing Factor	Contact ratio
Y_β	Helix Angle Factor	Helix angle of helical gear
K_L	Life Factor	Expected lifetime
K_{FX}	Size Factor of Root Stress	1.00 at the moment (unknown)
K_V	Dynamic Load Factor	Circumferential speed / Gear accuracy
K_O	Overload Factor	Motor / Impact from load
S_F	Safety Factor	It should be set to more than 1.2 for safety considerations

■ How to encourage bending strength

To encourage bending strength, values in the equation for allowable tangential force (7.1) should be set to; The value of denominator should be small & The numerator should be large

- (a) Use durable materials (Increase allowable bending stress at root)
- (b) Enlarge the gear size (For large module / wide tooth width)
- (c) Strengthen tooth profile (Decrease tooth profile factor)
 - Large pressure angle · Positive correction
- (d) Increase contact ratio (Decrease load distribution factor)
 - Small pressure angle · Large tooth depth
- (e) Improve accuracy

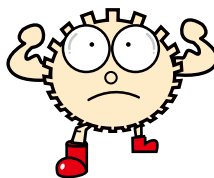

■ Surface Durability of Spur and Helical Gears JGMA402-01

Tooth surface durability is calculated in accordance with the contact stress, to figure out the strength against the tooth surface damage (Pitting).

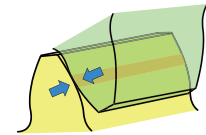

Fig. 7.2 Contact Stress

The allowable tangential force F_{lim} for surface durability is;

$$\text{Allowable Tangential Force } (F_{\text{lim}}) = \sigma_{\text{Hlim}}^2 d_{01} b_H \frac{i}{i \pm 1} \left(\frac{K_{\text{HL}} Z_L Z_R Z_V Z_W K_{\text{HX}}}{Z_H Z_M Z_e Z_\beta} \right)^2 \frac{1}{K_{\text{H}\beta} K_V K_O} \frac{1}{S_H^2} \quad (7.2)$$

Symbol	Name	Affected Factors and other Specifications
σ_{Hlim}	Allowable Hertz Stress	Material / Heat treatment
d_{01}	Pitch Diameter of Pinion	Pinion size (Diameter)
b_H	Effective Facewidth	Gear size
i	Gear Ratio (z_2 / z_1)	Ratio of the number of teeth
Z_H	Zone Factor	Helix angle / Profile shift coefficient
Z_M	Material Factor	Material combination
Z_e	Contact Ratio Factor	Transverse / Overlap contact ratio
Z_β	Helix Angle Factor	1.00 (Assumed)
Z_{HL}	Life Factor	Expected lifetime
Z_L	Lubricant Factor	Lubricants and Viscosity
Z_R	Surface Roughness Factor	Surface roughness
Z_V	Lubrication Speed Factor	Circumferential speed / Surface hardness
Z_W	Hardness Ratio Factor	Hardness of wheels
K_{HX}	Size Factor	1.00 assumed
$K_{\text{H}\beta}$	Longitudinal Load Distribution Factor	Gear Support / Stiffness etc.
K_V	Dynamic Load Factor	Circumferential speed / Gear accuracy
K_O	Overload Factor	Motor / Impact from load
S_H	Safety Factor	Set to more than 1.15 for safety considerations

■ How to increase surface durability

- (a) Use hard material treated by quenching (Increase allowable hertz stress)
- (b) Enlarge gear size (Large pitch diameter / Wide effective tooth width)
- (c) Increase contact ratio (Decrease contact ratio factor)
- (d) Improve accuracy

■ The strength calculator on KHK web site

The calculation of gear strength tends to be rather complicated. On our web site, we offer a strength calculator for KHK stock gears, which enables you to calculate gear strength automatically, by inputting values in accordance with your usage condition. For gear strength calculation, there are several formulas. The gear strength formula used in our calculator is based on JGMA (Japanese Gear Manufacturers Association) specifications.

8. Surface Treatment

Surface treatment when properly applied in accordance with usage conditions will improve the capabilities of gears.

Surface treatments are performed to make surface condition improvements on materials. The following are typical reasons for surface treatments, providing rust prevention and inhibiting abrasion by friction, to improve overall quality control.

- For corrosion resistance / For rust prevention
- For wear resistance
- For improvement in surface roughness (Smooth surface)
- For improvement in appearance
- Others (Improvement in fatigue strength, etc.)

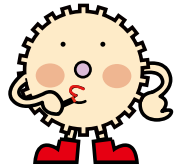

■ Electro-galvanizing

A typical plating method applied to prevent the rusting of steel. By applying a chromating process, the quality of the appearance also improves. Thickness of plating film is generally between 2 to 25 μ m.

◇ Uni-chromate

Silver white in color with slight bluish tint. The rust preventative properties are less than electro-galvanizing but the price is lower.

◇ Chromate

It has a multi-color appearance consisting of red, yellow and green. It has more corrosion resistance than Uni-chromate.

◇ Black-chromate

The color is basically black, but it looks slightly red depending on product shapes. It has the most corrosion resistance of all 3 types of electro galvanizing.

■ Electroless Nickel Plating

A plating method produced without the use of electricity. It inhibits corrosion/wear resistance. This plating is suitable for products that have; uniform thickness of plating film (3-10 μ m), complicated shapes, or high-precision is required.



Electro-galvanizing

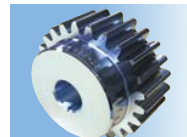

Uni-chromate

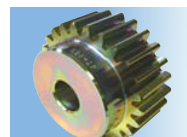

Chromate



Black-chromate



Electroless Nickel Plating

■ Black Oxide Treatment

A treatment from alkaline black oxidizing.

Applying a 140°C heated, strong alkaline processing liquid, the material is blackened by a chemical reaction within the steel. It is effective for rust proofing. On the surface it makes a ferrosferric oxide film, a thickness that is less than 3 μ m.



Black Oxide Treatment

■ Raydent Treatment

Raydent is a registered brand of Raydent Industrial Co., Ltd. Expect excellent rust prevention performance from this treatment. The color is black and the processing is similar to plating, as it makes a Raydent film (1 to 2 μ m) on the surface, which is extremely strong and will not separate.



Raydent Treatment

■ Phosphate Treatment

A treatment from an Iron phosphate type coating.

An Iron phosphate type film is a thin amorphous film used as a base coating for painted interior products.

◇ PALFOS M

A treatment with manganese phosphate that produces a plating thickness approximately 3 to 15 μ m. Used as a rust prevention film and also applied to sliding components, as it is wear-resistant.



PALFOS M

■ Solid Lubrication Treatment

A dry-coating spray, very useful as a solid lubrication treatment, where direct application of lubrication is not possible.

Achieved by spraying on tooth areas, it allows the lubricant agent to adhere and dry. It also allows compounded molybdenum to form a disulfide metal texture, to discourage corrosion.



Solid Lubrication Treatment

■ WPC Treatment

WPC is a treatment, effective in encouraging fatigue strength and reducing metal friction. This treatment helps improve fatigue strength, but does not improve bending strength. Applied by spraying the gears in very small amounts, 40 to 200 μ m, at the speed of 100 m/sec or more. By using this application, the process instantaneously generates heat and melts the metallic crystal, creating a fine coating from rapid cooling. Usually involves very little dimensional change; expected change would be within 1 to 2 μ m.

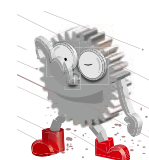

WPC Treatment

9. Manufacturing of Gears

KHK stock gears are produced by the following manufacturing processes.

For gear manufacturing, there are several fabrication approaches. However, we will show you how KHK Stock Gears are produced by introducing our typical cutting processes, selection of materials and the packaging of our gears.

9 – 1 Manufacturing Process of Spur Gears

Shown is a typical manufacturing process for the production of SS-type of KHK Spur Gears.
(Some photographs may not be of the SS-type of gears, and shown as examples)

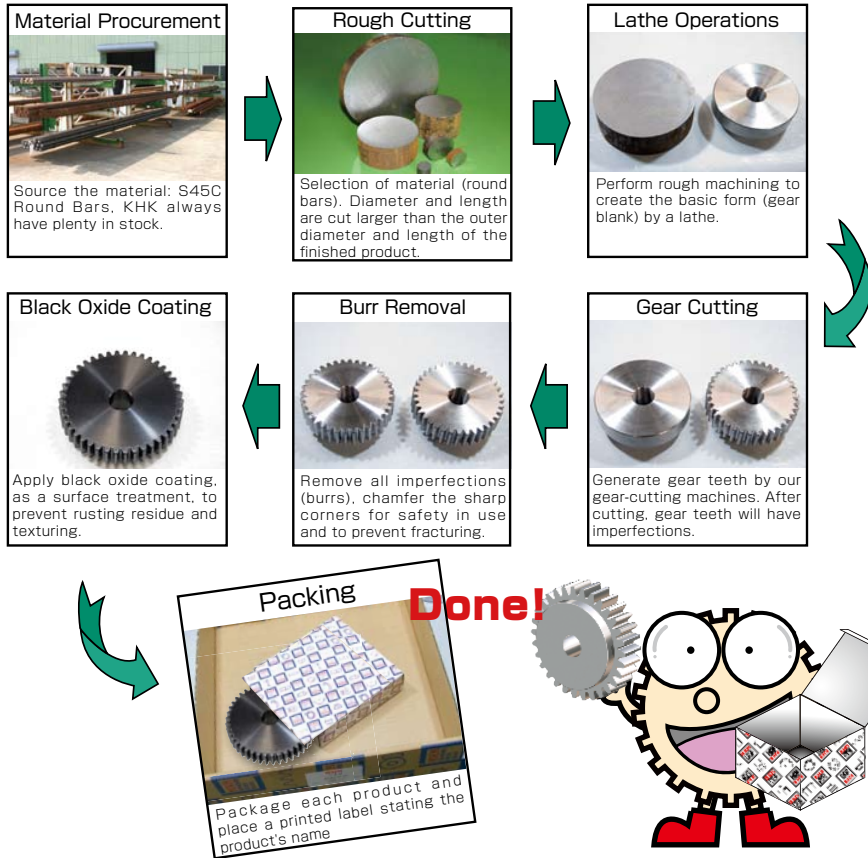

9 – 2 Manufacturing Process of Racks

Shown is a typical manufacturing process for the production of SRFD-type of KHK Racks.
(Some photographs may not be of the SRFD-type of gears, and shown as examples)

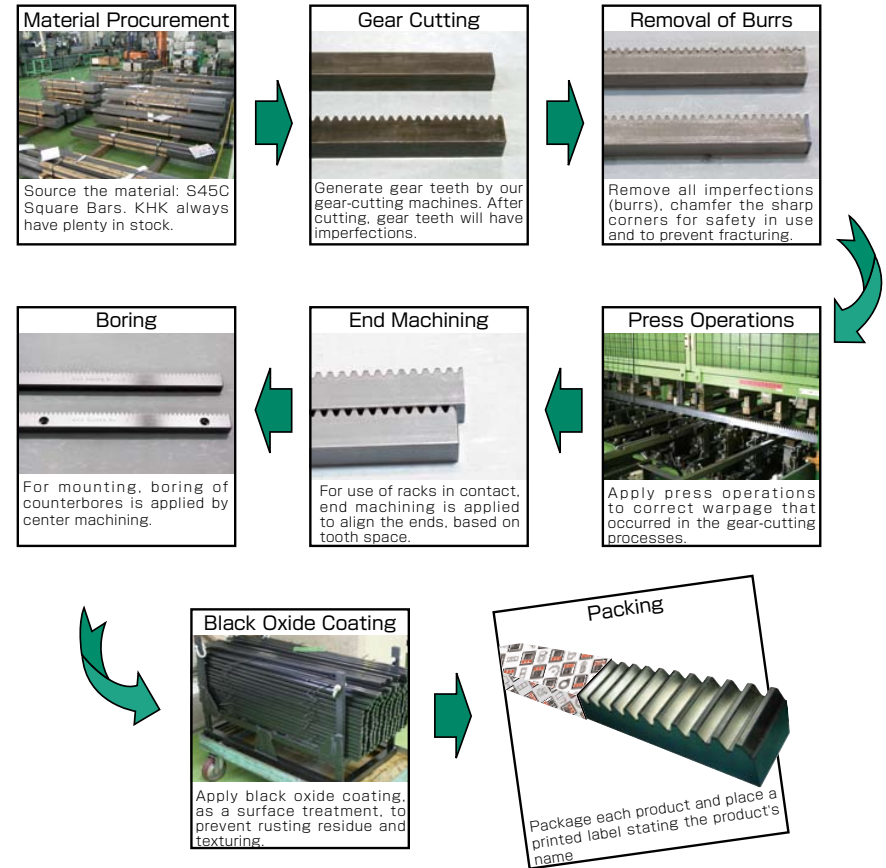

9 – 3 Manufacturing Process of Bevel Gears

This is a typical manufacturing process for SM-type of KHK Bevel Gears.

(Some photographs may not be of the SM-type of gears, and shown as examples)

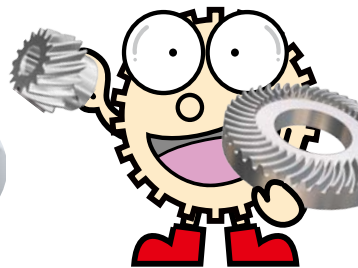
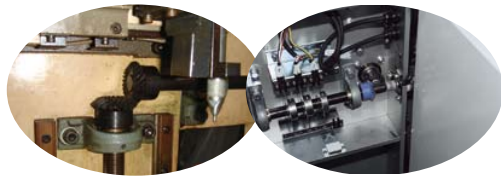
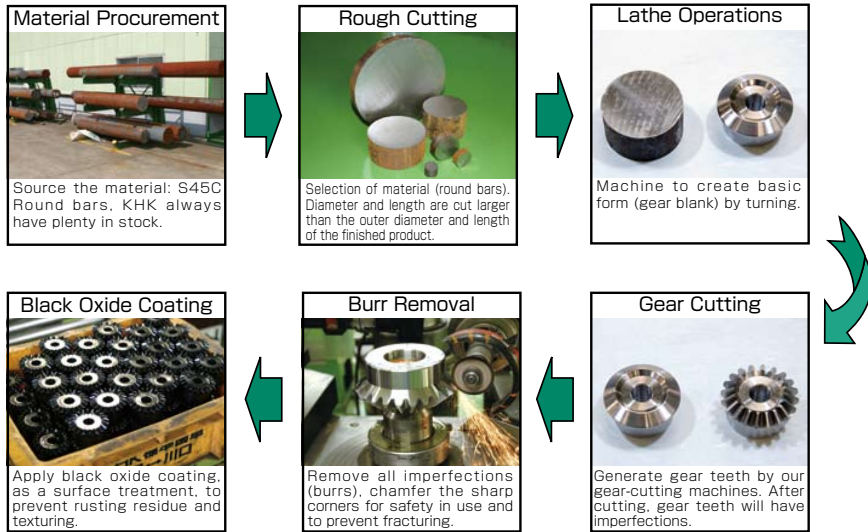

9 – 4 Manufacturing Process of Worm Gears

This is a typical manufacturing process for SW-type of KHK Worm Gears.

(Some photographs may not be of the SW-type of gears, and shown as examples)

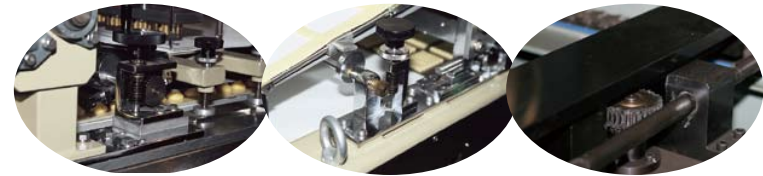
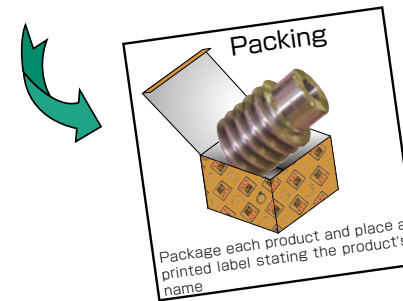
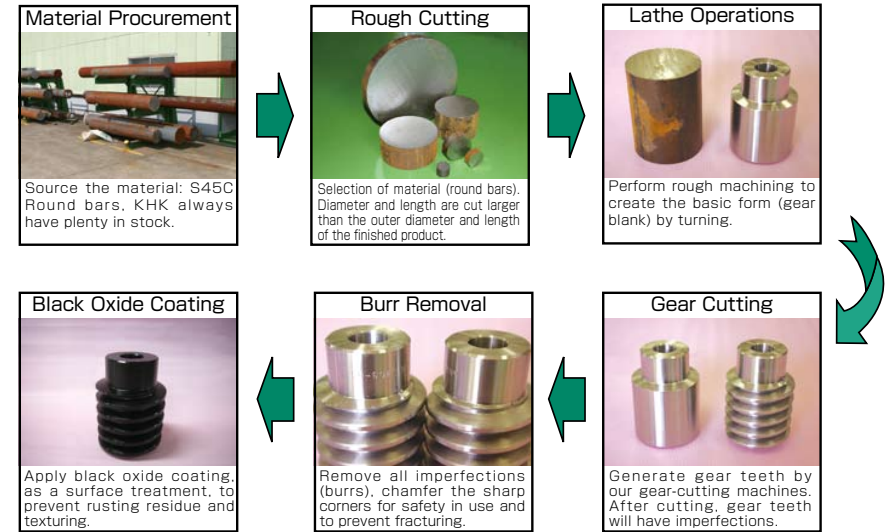

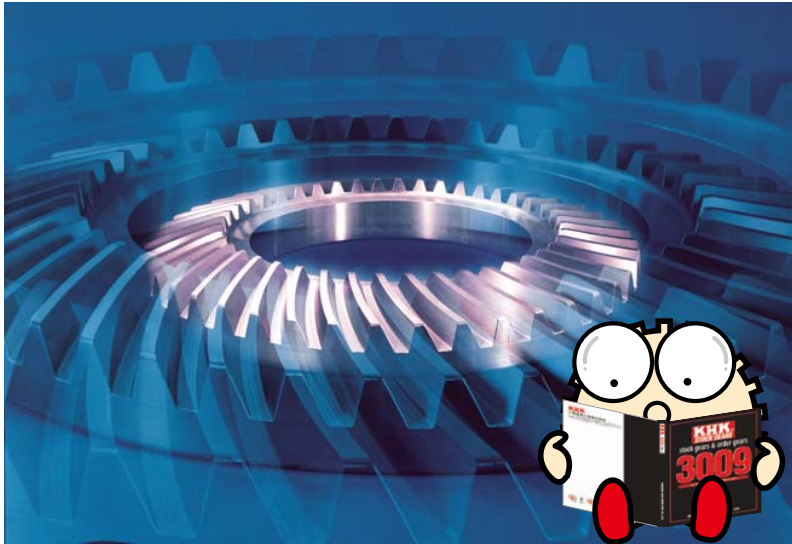

KHK[®] **KOHARA GEAR INDUSTRY CO., LTD.**

13-15 Nakacho, Kawaguchi-shi, Saitama-ken, 332-0022 Japan TEL:048-254-1744 FAX:048-254-1765

URL <http://www.khkgears.co.jp/en/> E-mail export@khkgears.co.jp

- All rights reserved herein and no portion of this booklet may be reproduced without the prior consent in writing from KHK Co.,Ltd.
- This booklet is published for the purpose of informing people about gears and is used as a KHK's sales promotion advertisement.
- No guarantee is given by KHK Co., Ltd. on the contents of these copyrighted works. Please note that, even if there are any errors therein, we shall not be held responsible, whatsoever.
- KHK Co., Ltd. reserves the right to make changes to the specifications and contents of this booklet, without notice.

The ABC's of Gears Basic Guide - B

First Published: September 1, 2007
Copyright by Kohara Gear Industry Co., Ltd.
All rights reserved.

Publisher Toshiharu Kohara
Published by Kohara Gear Industry Co.,Ltd.
〒 332-0022 埼玉県川口市
仲町13-17
Editor / Producer Team: ABC's of Gears

