

# KHK

# The ABCs of Gears

## Guide for Practical Use - C



A small robot for a Robot Competition. (Created by Mr. Miyake of KHK)



An automobile created for a formula car project at the Meiji University, which won a unique design award at the Student Formula SAE Competition in Japan.

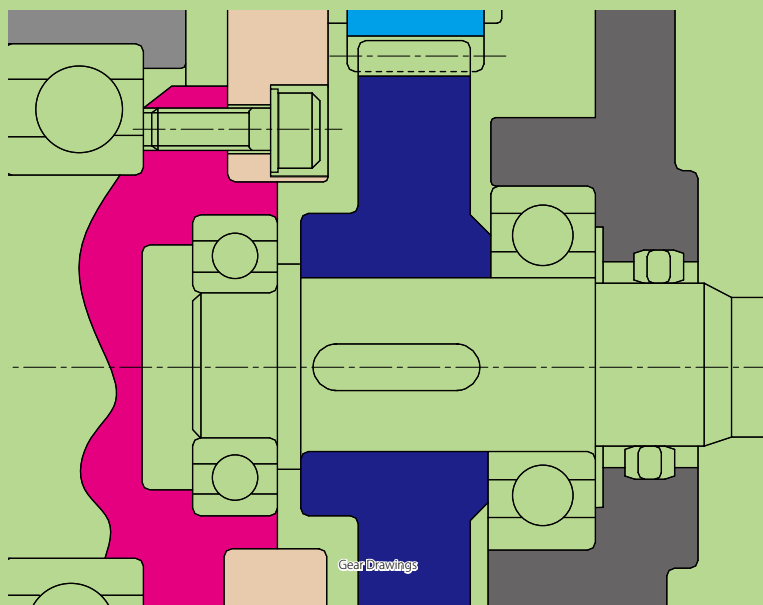

GearDrawings

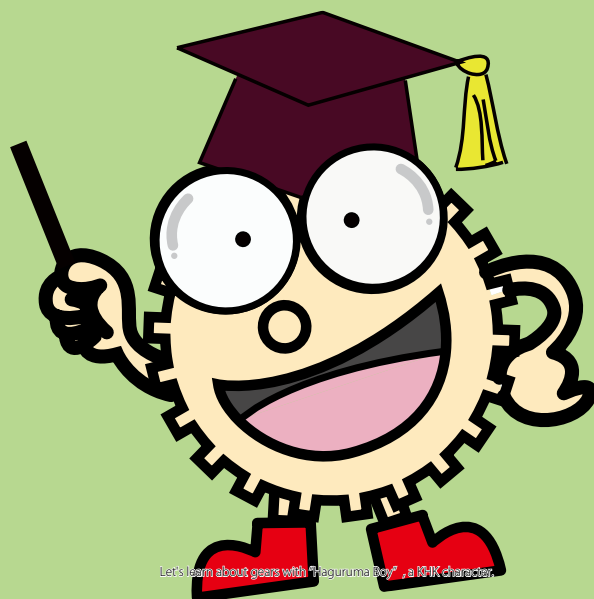

Let's learn about gears with "Haguruma Boy", a KHK character

**KOHARA GEAR INDUSTRY CO., LTD.**



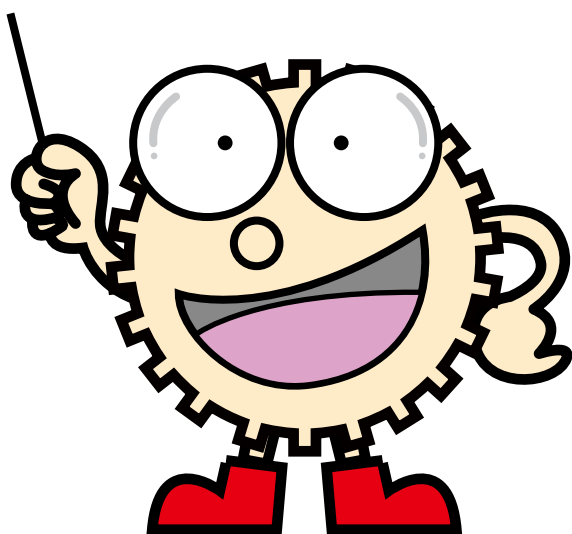

Hello, I am Haguruma Boy! The ABC's of Gears guide includes 3 editions; Introductory Guide-A, Basic Guide-B and Guide for Practical Use-C.

Did you find the Introductory Guide-A and Basic Guide-B useful? I hope they helped you learn about the history of gears and their usages.

This "Guide for Practical Use – C" introduces actual applications of KHK Stock Gears, for example, we will demonstrate the processes from selecting proper gears, to deciding the specifications, to creating drawings for production, as well as how to mount production gears and their confirmation. If you design gears by yourself, using specifications based on KHK Stock Gears will be of help to you in producing efficient designs. We hope you will make the best use of this guide.

# Contents

<b>1. How to Use Gears and the Selection Method</b>	<b>P 2</b>
1-1 Use in Parallel Axis Gears	P 4
1-2 Use in Intersecting Axis Gears	P 6
1-3 Use in Nonparallel and Nonintersecting Gears	P 8
1-4 Convenient Methods of Selecting Stock Gears	P10
<b>2. How to Determine Gear Specifications</b>	<b>P12</b>
2-1 Set-up for Gear Usage Conditions	P12
2-2 How to Set Gear Specifications	P13
2-3 Calculations for Gear Specifications	P16
<b>3. Gear Drawing Production</b>	<b>P18</b>
3-1 Gear Drawings	P18
3-2 Design Aids for Gear Drawing	P22
<b>4. Gear Installment and Lubrication</b>	<b>P24</b>
4-1 Installment of Gears and Confirmation	P24
4-2 Lubrication of Gears	P30
4-3 Selecting Lubricant Methods	P32
4-4 Safety Considerations and Precautions in Starting Operations	P35

# 1. How to Use Gears and the Selection Method

Gears are used to transmit power, many types of gears are varied depending on the direction of the power transmission, so, you need to select the most appropriate gear, first, by understanding how to use gears.

## Categories of Gears



Parallel  
Axes  
Gears



Intersecting  
Axes Gears



Nonparallel  
and Non-  
intersecting  
Gears



*"I wonder what kind of gears are used for that machine...."*

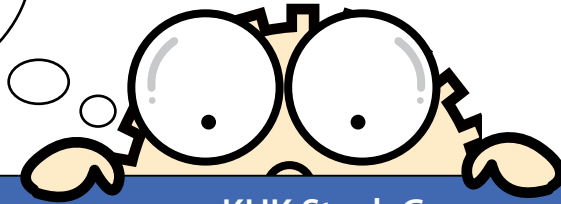

Gear Types	KHK Stock Gears				
Spur Gears	MSGA 	SSG 	SS 	SUS 	PS 
Helical Gears	KHG 	SH 			
Racks Helical Racks	KRG (F) (D) 	SRFD 	SUR (F) (D) 	PR (F) 	KRHG (F) 
Internal Gears	SI 	SIR 			
Miter Gears	MMSG 	SMSG 	MM 	SUM 	PM 
Straight Bevel Gears	SB·SBY 	SB 	SUB 	PB 	DB 
Spiral Bevel Gears	MBSG 	SBSG 	MBSA (B) 	SBS 	
Screw Gears	SN 	SUN 	AN 	PN 	
Worms	KWGDL (S) & AGDL 	KWG & AGF 	SWG & AG 	SW & BG·CG 	SUW & PG 
Worm Wheels					

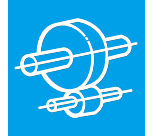

Parallel  
Axes  
Gears

## 1-1 Use in Parallel Axis Gears

### ■ Application of Spur Gears

#### ● Wire rod Feeder



An automatic wire rod cutting / straightening machine in the Takashima-style (TCH-9L), by Takashima Sangyo Co., Ltd.

#### Explanation of the Machine

This machine cuts and straightens wire rods automatically while preventing twists or bending. KHK gears (SS and SSA Spur Gears) are used in the device for feeding wire rods.

#### ● Food Feeder

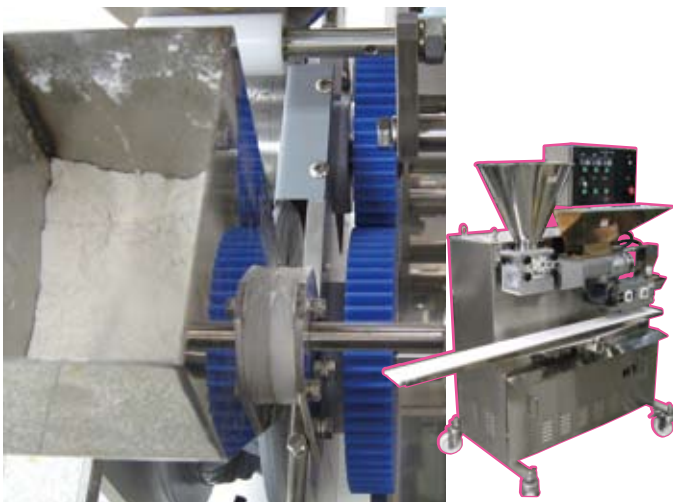

An automatic forming machine for food processing (JG-180A), by Jay Machine

#### Explanation of the Machine

A fully automatic forming machine that can produce more than 10 kinds of processed foods like Gyoza (Dumplings) or Xiaolongbao. KHK gears (PS and PSA Plastic Spur Gears) are used in this feeding device.

Spur gears or helical gears are used in many types of automobile transmissions.



Illustrations by  
PKDesign

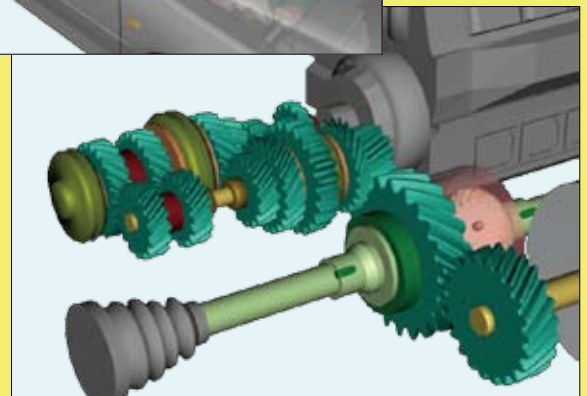



Parallel Axis Gears

■ Applications of Racks & Pinions

● Automatic Feeding Device

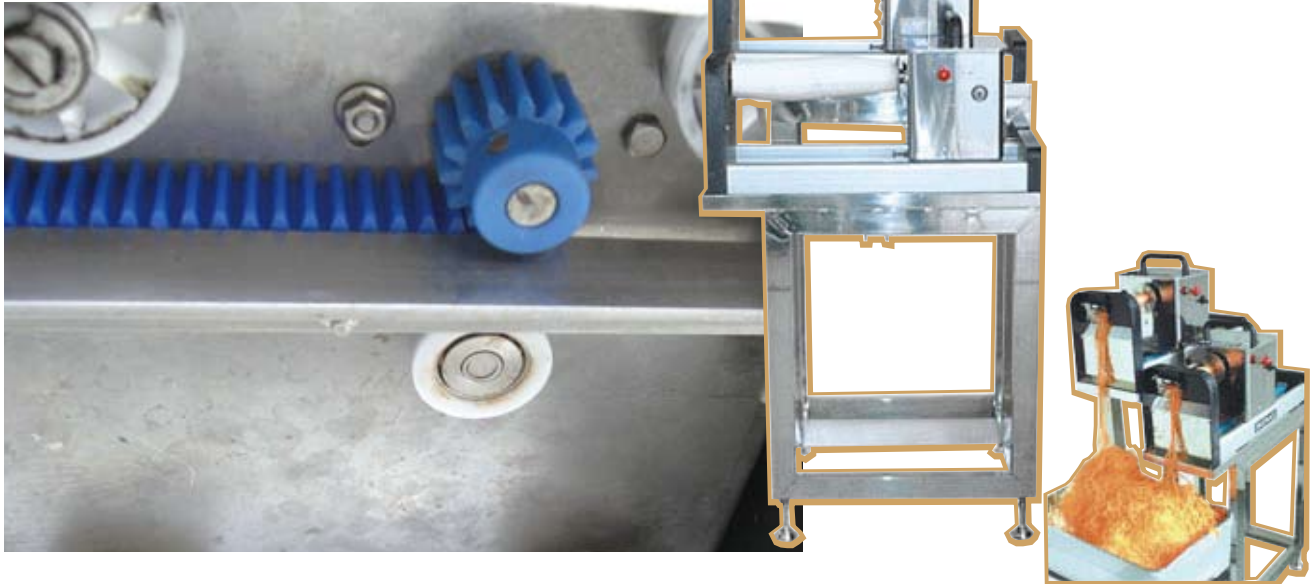

F-T200 High-speed vegetable cutting machine, by DREMAX Inc.

**Explanation of the Machine**

A high-precision vegetable cutting machine with a force-feed device used to produce sushi (sashimi) garnishes. To use this machine, just cut off both sides of a Daikon radish, and set to Daikon cutting, the machine performs automatically. In addition, handles two radishes at one time, for doubled efficiency. KHK gears (PR Plastic Racks & PS Plastic Spur Gears) are used in this machine.

● Opening and closing device for the fill valve

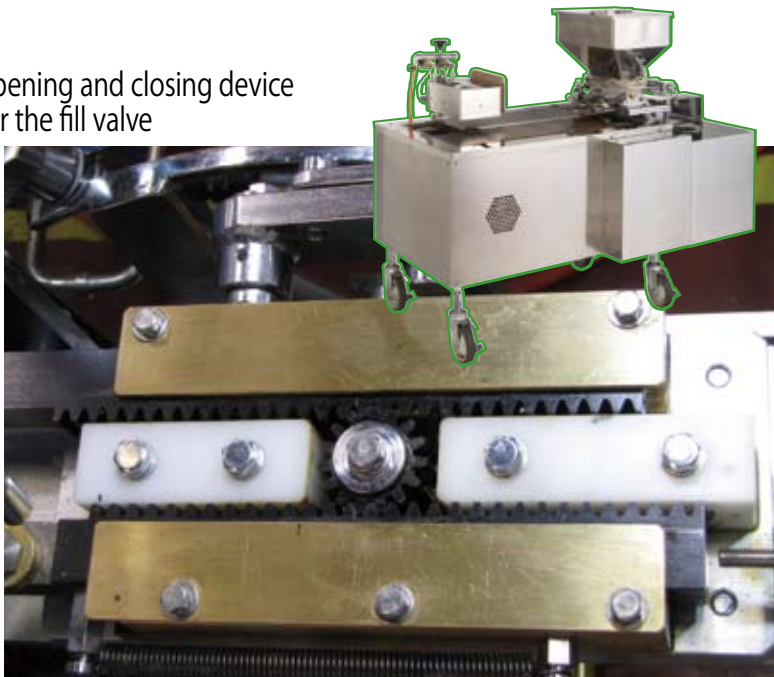

SDR-SGA-Z Waffle / Dorayaki Pancake baking machine, by MASDAC Co., Ltd.

**Explanation of the Machine**

An automatic baking machine that produces Waffles or Dorayaki pancakes. All the processes from shape forming, to loading, to the conveyer process is included in the automation system of this machine. KHK gears (SR Racks and SS Spur Gears) are used in the opening and closing device in the fill valve.

Rack & Pinion Gears are used in the steering of automobiles.



Illustrations by PKDesign

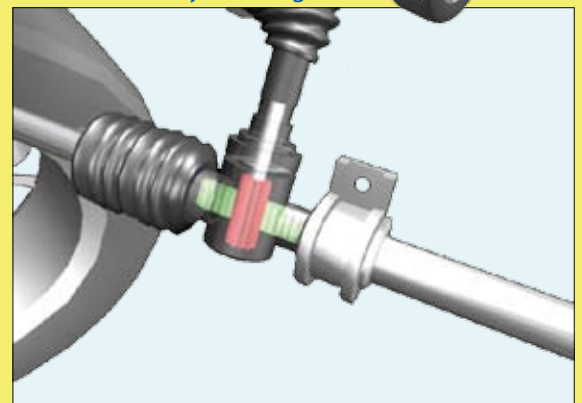

## 1 - 2 Use in Intersecting Axis Gears

### ■ Application of Bevel Gears

- A device for flipping baked dough



#### Explanation of the Machine

A fully automatic Dorayaki Pancake baking machine, where all the processes from dough filling, forming, baking, flipping, injecting bean jam, to pairing are included. KHK gears (SM Miter Gears) are used in the device for flipping baked dough.

The Differential Gear Mechanism used for automobiles is really super! It enables cars to turn a corner smoothly, and safely.



Illustrations by PKDesign

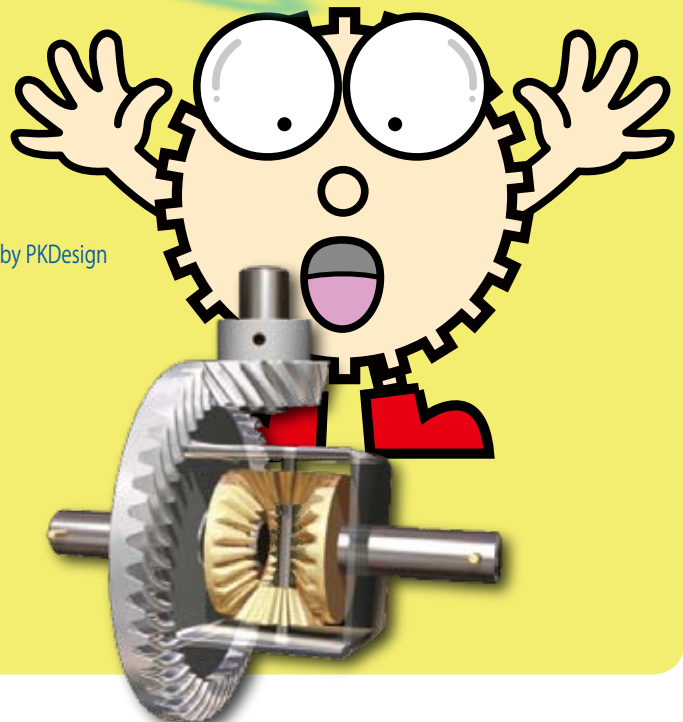
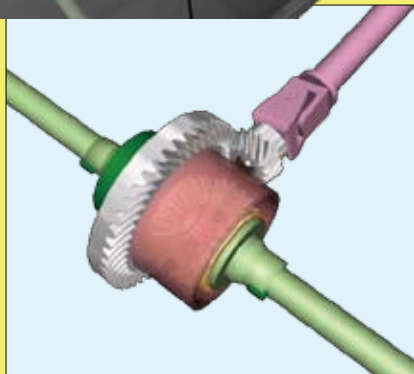



● Propeller Driver

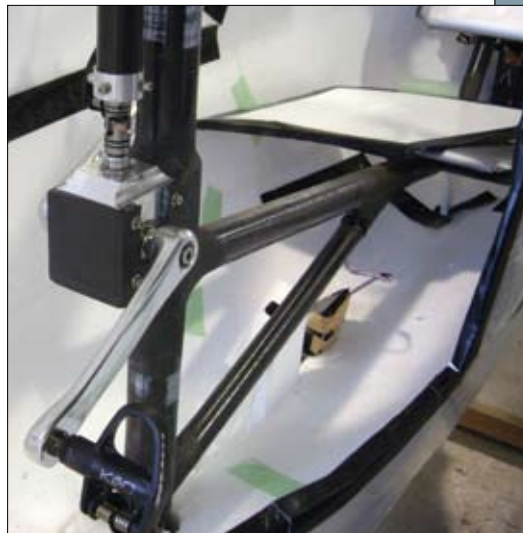
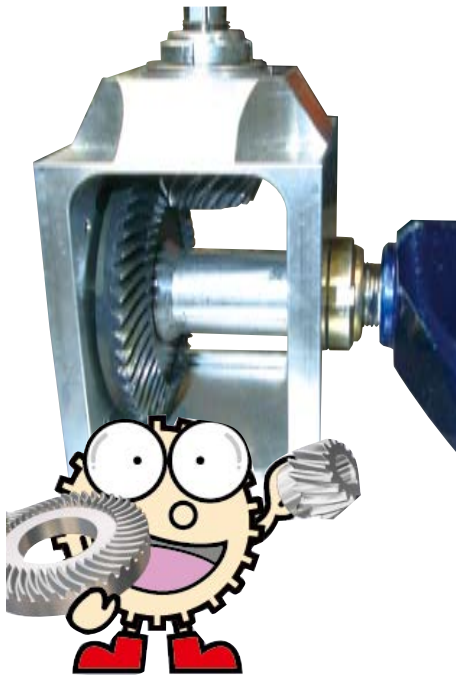

Human powered aircraft by the team "Meister" at the Tokyo Institute of Technology

**Explanation of the Aircraft**

A human powered aircraft designed by team "Mister" at the Tokyo Institute of Technology, who are known for winning prizes at the Birdman Completions, held in Japan. As the same as their competitors from the Nihon University, or Tohoku University, they have excellent technology and perfection in design that always win them prizes. KHK gears (MBSA(B) Spiral Bevel Gears) are used in the propeller driver.

● Front-and-Back Wheel Driver



Full-time 2WD Bicycle by SHESCO

**Explanation of the Bicycle**

This is a 2WD bicycle that enables you to ride on snow or ice. As the front wheel is connected to gears and a shaft, driving power from peddling can be received from both the rear and front wheels. KHK gears (SB Bevel Gears) are used in the front-rear-wheel driving device by a shaft-driven system.

# 1 - 3 Use in Nonparallel and Nonintersecting Gears

## ■ Application of Screw Gears

### ● Copperplate (baking pan) Feeder

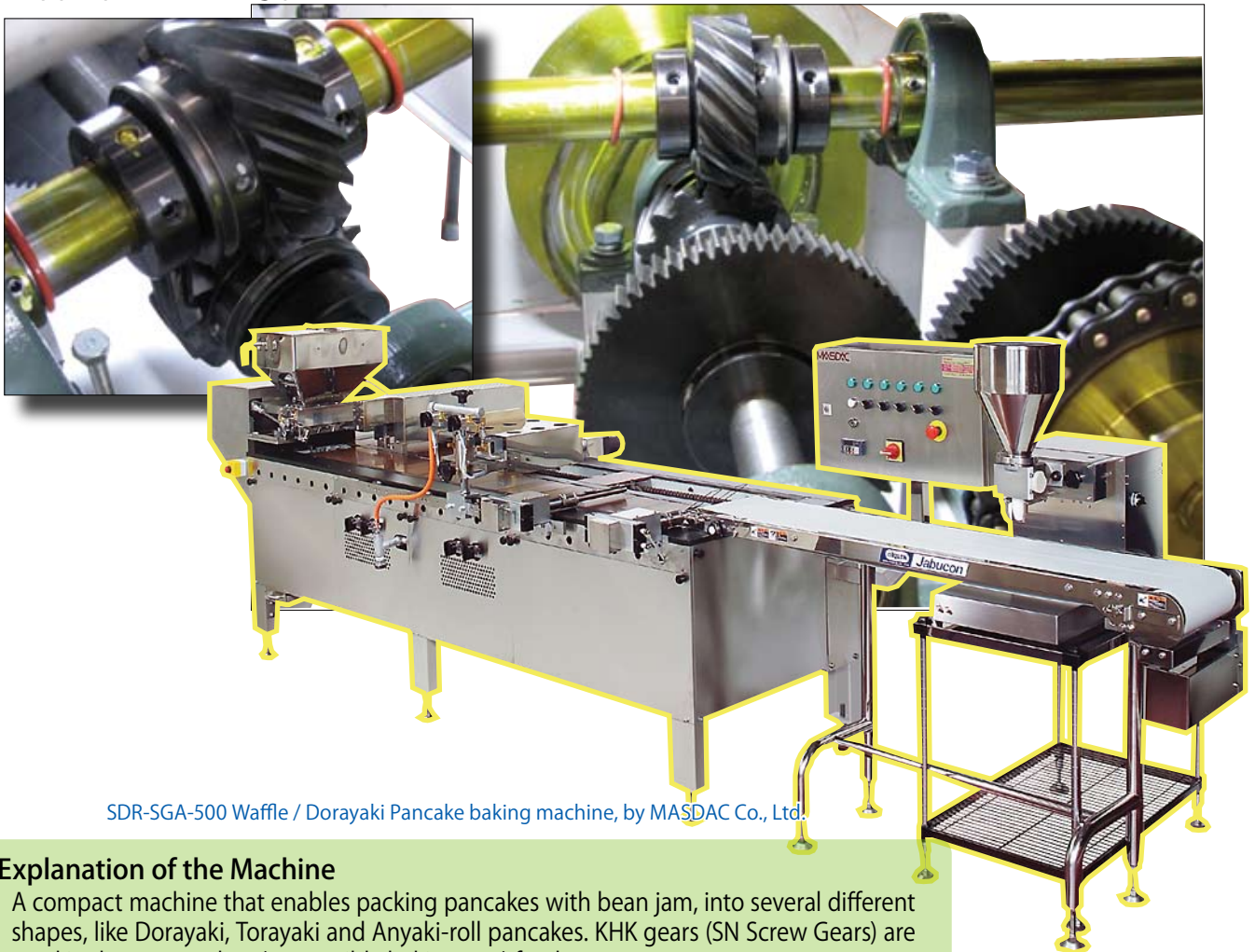

SDR-SGA-500 Waffle / Dorayaki Pancake baking machine, by MASDAC Co., Ltd.

### Explanation of the Machine

A compact machine that enables packing pancakes with bean jam, into several different shapes, like Dorayaki, Torayaki and Anyaki-roll pancakes. KHK gears (SN Screw Gears) are used in the copperplate (convertible baking pan) feeder.

### ● Feed Roller Device

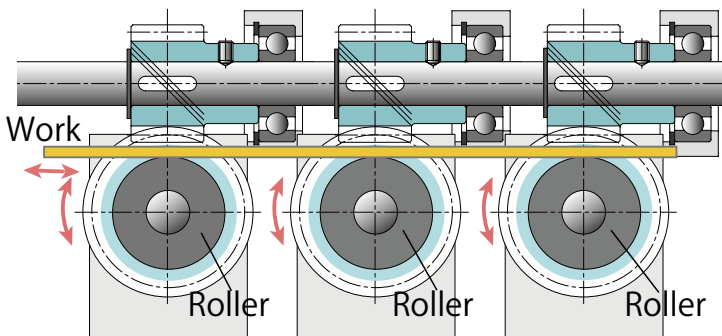

### Explanation of the Device

This is a device for transferring Work, from side to side. The Work moves on rollers spinning in the same direction by placing a number of screw gears with the same helix hands into an input shaft.

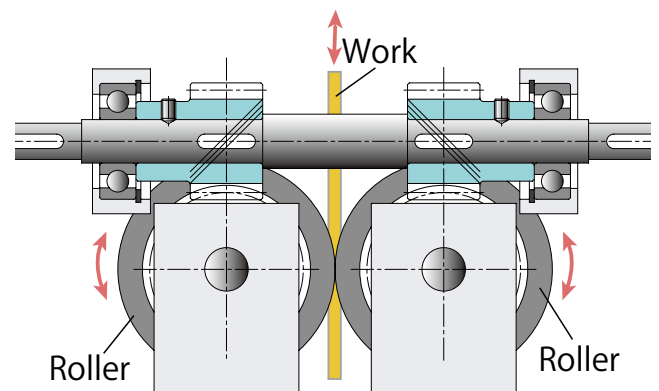

### Explanation of the Device

This is a device for transferring Work, up and down. The Work is captured and moves between rollers spinning in different directions by putting two screw gears with the different helix hands into an input shaft.



Nonparallel and Nonintersecting Axis Gears

■ Application of Worm Gear Pair

● Reversing Container Device



Steam Kettle SK-6 by Yaesu

**Explanation of the Machine**

A food processing machine with a water holding capacity of 360 L and a cooking capacity of 216 Kg. KHK gears (SW Worms and CG Worm Wheels) are used in the device for the reversing container.

● Foodstuff Filling Device

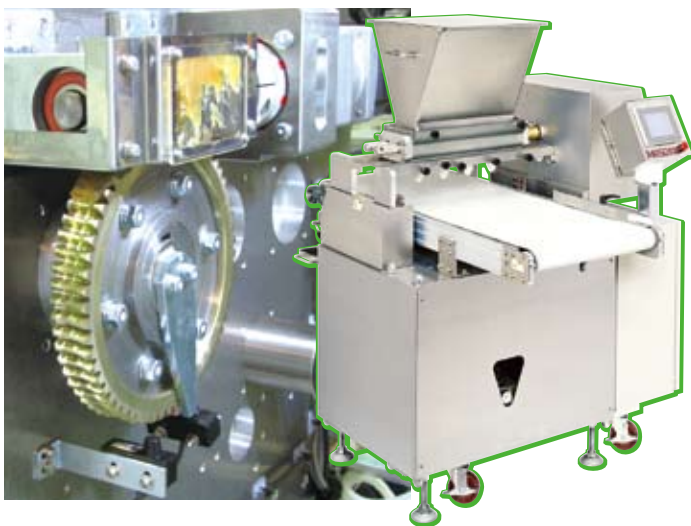

Foodstuff filling machine SAD-SD, by MASDAC Co., Ltd.

**Explanation of the Device**

A device for adding foodstuff in a designated quantity. Gears for driving and work output; KHK gears (KWGDL Duplex Worms and AGDL Duplex Worm Wheels) are used.

The use of a worm gear pair enables even a small engine to manage a large amount of work. A worm gear pair is used to move a windscreen wiper in combination with a linking mechanism.

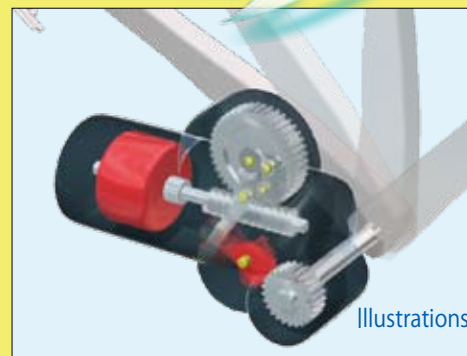

Illustrations by PKDesign

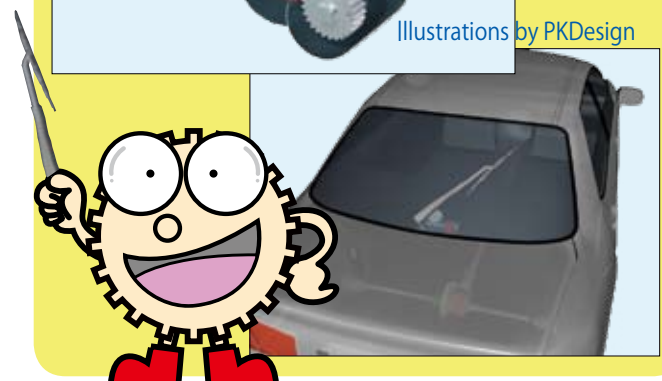

# 1 - 4 Convenient Methods of Selecting Stock Gears

Did you get an idea of the gears you want to use? Now, let's decide and select what types of gears to use. To select gears, you will find using our Web Catalog helpful and convenient. The Web Catalog gives you information on KHK Stock Gears, including 7000 configurations sorted in 140 items, and also shows you product photos and features, so that you can quickly find the proper gear that matches your intent.

**1. Search from Product Photo**

You can select KHK Stock Gears from viewing product photos, categorized by gear types.

Series reference	Catalog number reference	Strength table reference	Specifications
Steel Spur Gears (SSJ) Series list			
			Precision grade: JIS B1702-1 grade N0 (#1)
			Gear teeth: Standard full depth
			Pressure angle: 20°
			Material: S45C
			Heat treatment: -
			Surface hardness: -
			Surface treatment: -
			Surface finish: -
			Datum reference surface: -
			Surface teeth cut: -
			Modification: -

1 / 43 Page 2123 items in total

Catalog No.	Module	No. of teeth	Shaft	1	2	3	4	5	6	7	8	9	10
SS0.5-15A	0.5	15	S3T										
SS0.5-16A	0.5	16	S3T	3	9	0	0	0	0	0	0	0	0
SS0.5-17A	0.5	17	S3T	3	9.5	0.5	9.5						
SS0.5-18A	0.5	18	S3T	4	10	9	10						
SS0.5-19A	0.5	19	S3T	4	0.5	9.5							
SS0.5-20A	0.5	20	S3T	3	11	10							
SS0.5-21A	0.5	21	S3T	4	1	1							
SS0.5-22A	0.5	22	S3T	4	1	1							

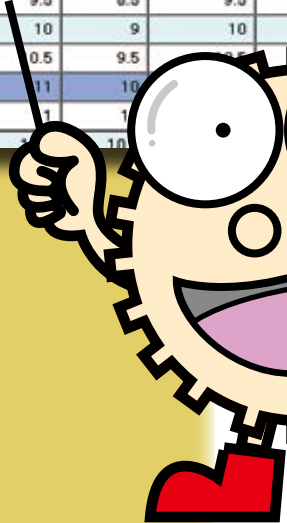

KHK Web Catalog Catalog numbe...

http://www.khkgears.co.jp/khkweb/search/catalog

Please input the Catalog Number to search.

SSG

Find Cancel

You can directly search for KHK Stock Gears by inputting a Catalog No.

## 2. Search from Catalog No.

**Gear strength table reference [ Spur Gears ]** Find Reset

Kind of strength

Selection by bending stress  
 Selection by surface durability  
 Selection by both bending strength and surface durability.

Load

kgfm

Unit conversion

kgf·m(Torque)     kgf·cm(Torque)     kgf·mm(Torque)  
 Nm(Torque)     kgf(Tangential Force)     gf(Tangential Force)  
 N(Tangential Force)     kW(Power)     W(Power)

### 3. Search from Gear Strength

● KHK Stock Gears can be selected from strength that can withstand expected loads.

Gear specification reference Custom Gears How to use Web catalog HO

Material: less than HB194  
 Surface treatment: Black oxide (±2)  
 Profile: Cut  
 Bore (H7)  
 Conditions: Possible

Diagram

Search

Rim O.D.	Key width	Key depth
5	11	16
5	11	16
5	11	16
11	16	16
16	16	16
16	16	16
16	16	16

**Gear specification reference[Spur Gears, Helical Gears]** Find Reset

Size of Teeth

m0.5     m0.8     m1     m1.25     m1.5  
 m2     m2.5     m3     m3.5     m4  
 m5     m6     m8     m10     DP2.5  
 DP5     DP10     DP15     DP20     Does not matter.

No. of Teeth

Material

Does not matter     S45C (contain Sintered Metal)  
 SCM415     SCM440  
 Stainless Steel     Copper alloy  
 MC nylon     Duracon (Acetal/Copolymer)

Bore

No limitation downward: [v] to No Upper Limit [v]

Gear precision

Does not matter.  
 High Precision (Equivalent to JIS N5/Old JIS grade1)  
 Slightly Better (JIS N6-N7/Old JIS 2-3)  
 Normal (JIS N8/Old JIS 4)  
 Precision not needed (JIS grade N9-N12/Old JIS grade 5-8)

Price

No Upper Limit. [v]

Find Reset

### 4. Search from Gear Specifications

● You can select KHK Stock Gears that have the exact specifications you require.

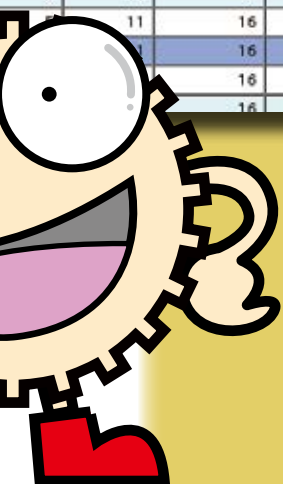

# 2. How to Determine Gear Specifications

Capability of gears varies depending on the material to be used, heat treatment, precision and surface treatment. If you have selected gears in accordance with the guidance mentioned in Chapter 1, you will now need to consider gear specifications.

## 2-1 Set-up for Gear Usage Conditions

First, you need to set up operating conditions for the machine, and this includes the conditions for using gears. Conditions to be set will differ according to the purpose that each designer has, however, as an example, we will use settings for Spur Gears (Parallel Axis) used in the wire rod cutting / straightening machine as shown in Chapter 1.

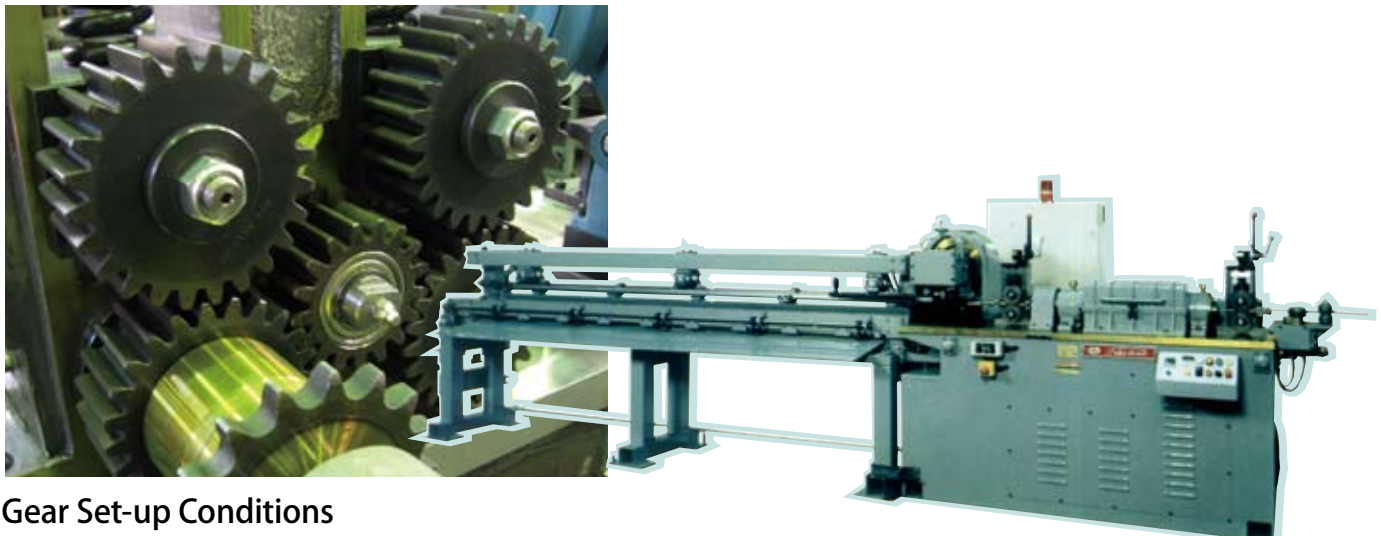

### ■ Gear Set-up Conditions

Items	Set Value	Description
Motor Output	0.5 kW	Select and set-up an appropriate motor by considering the maximum load torque, or input rotation.
Input Rotation	60 rpm	60 rpm (low speed). In regards to using high speeds, remember, there will be increases in vibration and noise.
Transmission Ratio	Approx. 1.4	This value is for the transmission ratio of Input Shaft and Output Shaft. It is calculated by the No. of Teeth of Gear ÷ No. of Teeth of the Pinion.
Rotational Direction	One-way rotation	Load conditions may be better than using bidirectional rotation, as the load direction is fixed.
Gear Support	Supported on one end	As the shaft deflects, conditions may worsen than in symmetric support.
Center Distance	Approx. 80mm	Decide the center distance by considering the space for gear-mounting.
Lubrication	Grease lubrication	The condition set here is barely acceptable. Gears should be contained in an oil-bath or have forced lubrication.
Load Torque of Output Shaft	6.5kgf·m	This is a basic value used when selecting gears for desired strength. Set load torque as accurate as possible.
Desired Life	5 hours a day, For a duration of 3 years, working 5 days per week.	The desired lifespan of gears can not be calculated, however, this condition helps when selecting gears for strength.

\* The values set above are just assumed values we created and not data for actual machine specifications.

## 2 - 2 How to Set Gear Specifications

The next step is setting up detailed specifications that will fulfill the conditions of Gear size, strength, accuracy and cost, among others: there are many factors to consider. By using the KHK Web Catalog, you can quickly decide proper specifications. Now, let's try setting up specifications for a spur gear in accordance with the conditions from the previous page.

### ■ Considerations for Gear Strength

When considering gear strength, it is set so that the gear specification has the allowable bending strength and the allowable surface durability, larger than the load torque. However, there are cases when the specification is decided only by depending on the bending strength; if the gear is used at low-speed rotation, in the short term. Gear specifications are basically decided from load torque, but they are also decided from the motor's output torque, if the load torque is unknown. However, care should be taken, as it tends to be over-engineered. The following table shows the results in selecting KHK Stock Gears, having the allowable bending strength and surface durability that fulfill the load torque of 6.5 kgf/m.

Spur Gear Products found by the search function "Search from Gear Strength" in the KHK Web Catalog (Excerpt)

Product	Material	Heat Treatment	Precision (Grade)	Torque (kgf·m)	
				Bending strength	Surface durability
MSG44 -15	SCM415	Overall carburizing	N5	59.7	30.8
SSG4 - 15	S45C	Tooth surface induction hardened	N7	20.1	7.55
SS4 - 32	S45C	None	N8	72.1	6.87
SSA4 - 32	S45C	None	N8	72.1	6.87
SUSA4 - 40	SUS303	None	N8	53.2	7.86

\* In the Web Catalog, the search results list a series of gears with the minimum no. of teeth, that fulfill the load torque, and sorted by identical modules. The listed products, having a larger no. of teeth, also tolerate the load torque.

### < Hints >

To encourage gear strength, there are several methods to use, like enlarging the gear size, expanding tooth width, and use stronger (with larger allowable stress value) material. Also, if none heat-treated gears made of S45C material with applied heat treatment on teeth are used, the surface durability becomes 4 or 5 times larger. However, you should be careful as the tooth accuracy decreases, due to the heat.



Strength Calculation for SSA4 – 24 by the tool "Gear Strength" in the dimension table in the Web Catalog

Product	Material	Tooth surface induction hardened	Precision (Grade)	Torque (kgf·m)	
				Bending strength	Surface durability
SSA4 - 24	S45C	None	N8	48.8	3.41
		Yes	N9	44.3	15.2

\* The strength calculation above shows the comparison of treated and none-treated products. KHK set the values (default) according to assumed usage conditions.

### ■ Considerations in Gear Size

When considering gear sizes, the following specifications are required; space for mounting the gear, center distance, modules and the number of teeth in consideration with transmission ratio. The table below shows the selection of KHK Stock Gears, which fulfills the following; Center Distance of approx. 80 mm and Transmission Ratio of approximate 1.4.

Center Distance	Transmission Ratio	Module	Pinion	Gear	KHK Stock Gears
80	1.46	2.5	26	38	SSG, SS, PS
81	1.45	3	22	32	SSG, SS, SSA, SUS, SUSA, NSU, PS, PSA
82	1.41	4	17	24	MSGa, MSGB, SSG, SS, SSA

### ■ Setting up gear specifications

In accordance with the characteristics of machines, or the usage environment, there are other gear specifications that you need to consider. Based on the usage conditions and the considerations we made in the previous sections, let's set up detailed specifications now. Since we have selected KHK Stock Gears that fulfill usage conditions, we introduce the specifications set-up accordingly to these explanations. We recommend the use of KHK Stock Gears as they provide various advantages, such as reducing the cost of manufacturing, design time-savers and other advantages.

**Haguruma Kobo**, the modification service for KHK Stock Gears is available.

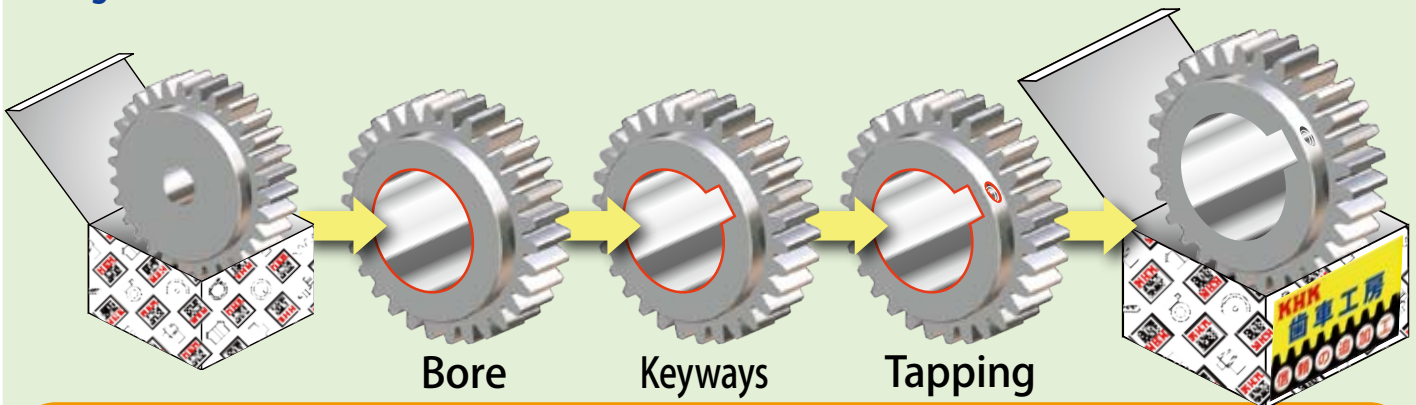

The following modifications are also available from the Haguruma Kobo.

(1) Surface Treatments

1. Plating

- ① Galvanizing ... Black and White Chromate (Trivalent chrome)
- ② Chroming ... Black and Gloss
- ③ Nickel Plating. ... Electrolytic Nickel and Electroless Nickel
- ④ Raydent ... Raydent Treatment and Fluoride Raydent Treatment

2. Phosphate Treatment

- ① PALFOS M ... Manganese phosphate treatment
- ② Defric Coating ... Solid film lubricants

3. Black Oxide Treatment

(2) Heat Treatment

- 1. Induction Hardening
- 2. Nitriding
  - ① Gas nitriding
  - ② Gas soft-nitriding
  - ③ Salt bath soft-nitriding

(3) Others

- 1. Wire cutting
- 2. Milling



### ● Selected KHK Stock Gears

Pinion : SS4 - 17, Tooth surface induction hardened Gear : SSA4 - 24, Tooth surface induction hardened

Specifications	SS4 - 17	SSA4 - 24
Gear Type	Spur Gear	Spur Gear
Precision Grade	JIS grade N9 or equivalent	JIS grade N9 or equivalent
Module	4	
Pressure Angle	20°	
No. of Teeth	17	24
Face Width	40mm	40mm
Pitch Diameter	68mm	96mm
Profile Shift Coefficient	0	0
Span measurement over k teeth	18.67 (2 teeth)	30.87 (3 teeth)
Material	S45C	S45C
Heat Treatment	Tooth surface induction hardened HRC45 - 55	Tooth surface induction hardened HRC45 - 55
Surface finishing	Cutting	Cutting
Allowable Torque (Bending Strength)	41.2 kgf·m	64.7 kgf·m
Allowable Torque (Surface Durability)	4.79 kgf·m	6.77 kgf·m
Transmission Ratio	1.41	
Center Distance	82mm	

#### < Descriptions >

##### ● Gear Strength

From the desired performance of working 5 days per week, 5 hours per day for 3 years, and, the value of rotation, n, of the Pinion (60 rpm), the duty circle, X, is calculated as follows:

$$X = 60 \text{ rpm} \times 60 \text{ min.} \times 5 \text{ hrs} \times 260 \text{ days} \times 3 \text{ years} = 1.4 \times 10^7$$

By considering the load torque as well as the durability and bending strength, the specification is determined so that the surface durability of the gear fulfills the load torque of 6.5kgf·m. Also, it is set so that the load torque for the pinion fulfills 4.61 kgf·m (Load torque for

$$\text{Gear } 6.5 \div \text{Transmission ratio } 1.41).$$

##### ● Gear Size

The size is determined so that the transmission ratio (approx.1.4) and the center distance (approx. 80mm) can be as close as possible.

##### ● Others

From the characteristics of the machine used and the usage conditions (Rotation of 60 rpm, and other parameters), we see no need in considering noise, rust prevention or lightweight. So, we select gears KHK Stock Gears that have a precision grade of JIS N9 or equivalent, and material S45C, for cost savings.

#### ■ Setting for gear forms

After the specifications are determined, the form and dimensions of the gear should be designated with consideration for gear installment. According to the shaft diameter, you need to determine appropriate dimensions for bore, keyways, attaching screws and other parameters. The use of KHK Stock Gears allows you to make easy settings for secondary operations by using the function in the KHK Web Catalog. (Please see page 16 for details) For quality operations, Haguruma Kobo, the KHK's modification service is also available.





To create **drawings for secondary operations** of KHK Stock Gears, please use the function in the KHK Web Catalog. (Numbered item ① in the diagram below.)

This function allows you quick drawing of secondary operations, by imputing dimensions of bore, keyways, taps, etc. Make the best use of this function for time and laborsavings, leading to cost-cutting. For details, see page 22.

The function for **Strength Calculation** is also available in our Web Catalog. (Numbered item ② below)

**Specifications**

Precision grade	JIS B 1702-1 grade NB (#1)	Surface hardness	less than HB194
Gear teeth	Standard full depth	Surface treatment	Black oxide (#2)
Pressure angle	20°	Surface finish	Cut
Material	S45C	Datum reference surface for teeth cutting	Bore (H7)
Heat treatment	-	Modifications	Possible

40 / 43 Page 2123 items in total Module 0.5 No. of Teeth All Find < 1 ... 31 | 32 | 33 | 34 | 35 | 36 | 37 | 38 | 39 | 40 ... 43 >

Catalog No.	Module	No. of teeth	Shape	Bore A	Hub dia B	Pitch dia C	Outside dia D	Face width E	Hub Width F	Total length G	Web thickness H	Rim O.D I	Key width	Key dia
SS4-12	4	12	S1	20	35	48	56	40	20	60				
SS4-13	4	13	S1	20	38	52	60	40	20	60				
SS4-14	4	14	S1	20	40	56	64	40	20	60				
SS4-15	4	15	S1	20	45	60	60	40	20	60				
SS4-16	4	16	S1	20	50	64	72	40	20	60				

① Drawing display/Create drawings for modification ② Gear Strength

SS4-17 Strength calculation of gears

Meshing Gear:  Spur Gears  Rack  Internal Gears

Meshing number of teeth: 24

Meshing Face Width: 40

Meshing Surface finish:  Cut  Ground

Rotating Speed: 60 rpm

Rotating Repeat: Above 10,000,000

Dimension Factor of Root Stress: 1.00

	Impact from Prim Mover	Impact from Load Side of Machine		
		Uniformed Load	Medium impact	Heavy impact
Uniformed Load	1.00	1.25	1.75	
Light impact	1.25	1.50	2.00	
Medium impact	1.50	1.75	2.25	

Kinematic Viscosity of Lubricant: ISO VG 32

Safety Factor: 1.2

Method of Gear shaft Support:  Bearing on One End  Bearing on Both Ends

Direction of Load:  Unidirectional  Directional

Additional Harden:  With Harden  Without Harden

Unit:  kgf  N

**Definition of Bending Strength**

The allowable bending strength of a gear is defined as the allowable tangential force at the pitch circle based on the mutually allowable root stress of two meshing gears under load.



Example of failure due to insufficient bending strength

**Definition of Surface Durability**

The surface durability of a gear is defined as the allowable tangential force at the pitch circle, which permits the force to be transmitted safely without incurring surface failures.



Example of defacement due to insufficient surface durability

**Calculation Results**

--- Bending Strength [JGMA401-01] ---		--- Surface Durability [JGMA402-01] ---	
Allowable Tangential Force(kgf)	836.3892	Allowable Tangential Force(kgf)	43.1448
Allowable torque(kgfm)	26.7645	Allowable torque(kgfm)	1.3806
Allowable power (kW)	2.7486	Allowable power (kW)	0.1418

# 3. Gear Drawing Production

To create gears, drawings are necessary. If you provide a gear drawing with basic specifications, you can ask KHK for the production.

## 3-1 Gear Drawings

Since many gears are cylindrical shaped and have a symmetrical profile, the dimensions of gears can be indicated on a drawing with a front view, or a drawing with both front and side views. Gear drawing involves specific technical terminology and descriptive methods, however, it is not so difficult once you understand the basics of gears and mechanical drawing. In this chapter, we will show you a few drawing examples to help you create gear drawings for different types of gears. Drawings are an agreement between a client and a gear manufacturer to show confirmed contractual obligations, so the designer needs to formalize his/her intentions and requirements in drawings, clearly and in detail.

### Spur Gear Drawing

Draw the shape and specify dimensions. For cylindrical gears, draw a front view and a side view, based on the axis view of the centerline. Then, specify dimensions of the basic shape and necessary tolerances.

This shows the surface roughness of the overall product. If the roughness level differs partially, directly specify finish marks in the shape diagram.

Black oxide finish

Technical drawing details:
 

- Front view dimensions: Total length 60<sup>+0.15</sup>, section length 40, offset 20, hole diameter 10, hole type M8.
- Side view dimensions: Key width 10 ± 0.018, gear thickness 3.3<sup>+0.2</sup><sub>0</sub>.
- Internal diameters:  $\phi 30H7$ ,  $\phi 76_{-0.1}$ .
- Surface finish symbols:  $\sqrt{\text{Ra}}$  and  $\sqrt{\text{Rz}}$  marks.

Roughness		Tolerance	
Sym.	Ra	Dimension & Up ~ Max.	Tol. mm
$\sqrt{\text{Ra}}$	0.4a	0.5 ~ 6	±0.1
$\sqrt{\text{Rz}}$	1.6a	6 ~ 30	±0.2
$\sqrt{\text{Ra}}$	3.2a	30 ~ 120	±0.3
$\sqrt{\text{Rz}}$	6.3a	120 ~ 400	±0.5
$\sqrt{\text{Ra}}$	25a	400 ~ 1000	±0.8
$\sqrt{\text{Rz}}$		1000 ~ 2000	±1.2
		Angle	±0.5°

Spur Gears Data	
Class	JIS B 1702-1 grade 1B
Reference section of gear	
Tooth Form	Standard full depth
Module	4
Pressure Angle	20°
No. of Teeth	17
Helix Angle & Hand	
Pitch Diameter	68
Addendum Modification	0
Addendum	4
Whole Depth	9
Outside Diameter	76
Thickness	18.67 <sup>±0.15</sup>
Backlash	
Mating Gear	
Heat Treatment	
Induction Hardening	HRC45-55
Depth	
Remark	

This is the section where you specify gear specifications determined in Chapter 2. It is essential to specify the following specifications; Gear Type, Precision Grade, Module, Pressure Angle, No. of Teeth and Heat treatment.

Mark	Name	Matl	Remarks
Drw. by	D.S	11. 10. 11	Title
Checked by	M.T	11. 10. 12	
Scale	4/5		
<b>KHK</b>			Dwg. No.
KOHARA GEAR INDUSTRY CO., LTD.			ABC001

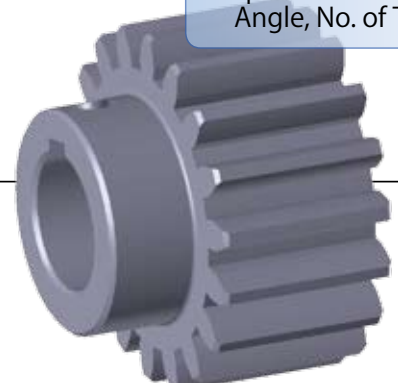

Title and Dwg. No. are optional items. Adding a part number will be of help for drawing management, as it quickly tells you which machine the gear is used for.

### Internal Gear Drawing

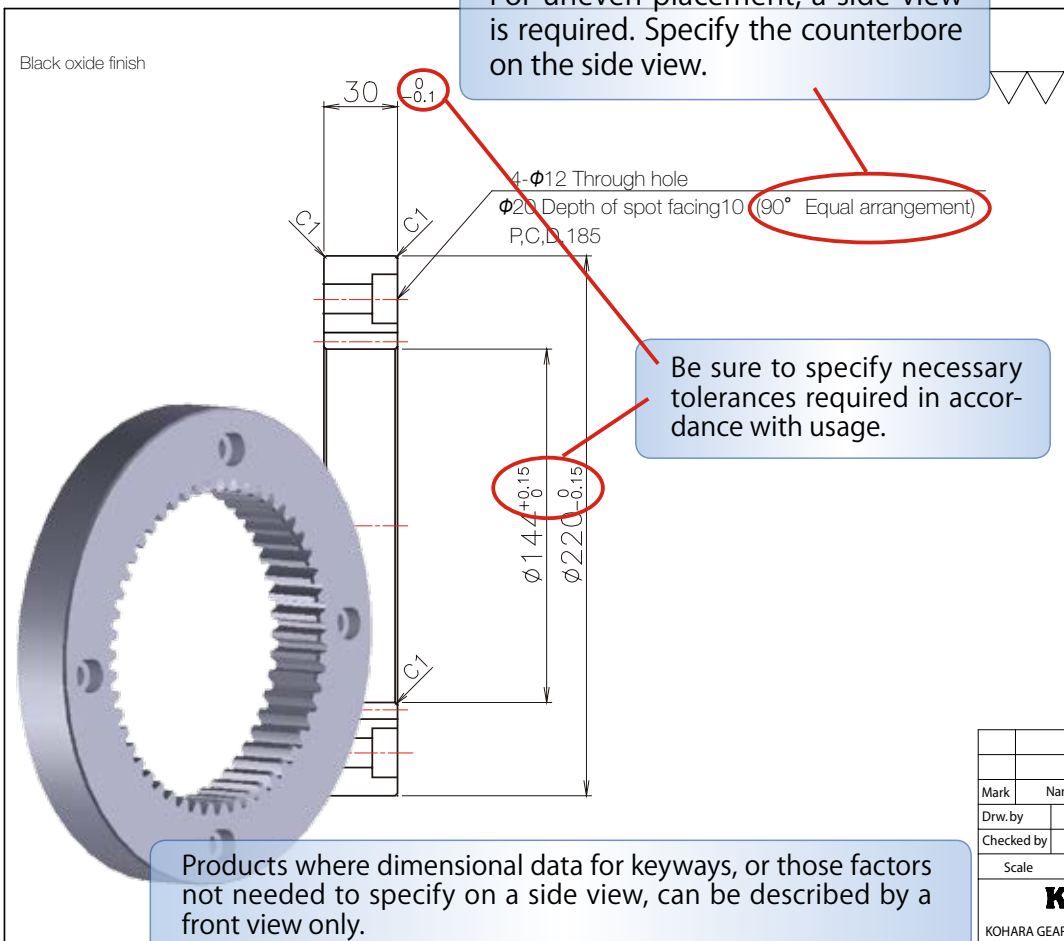

Roughness		Tolerance	
Sym.	Ra	Dimension & Up ~Max.	Tol. mm
$\sqrt{\text{Ra}}$	0.4a	0.5 ~ 6	$\pm 0.1$
$\sqrt{\text{Ra}}$	1.6a	6 ~ 30	$\pm 0.2$
$\nabla$	3.2a	30 ~ 120	$\pm 0.3$
$\nabla$	6.3a	120 ~ 400	$\pm 0.5$
$\nabla$	25a	400 ~ 1000	$\pm 0.8$
~		1000 ~ 2000	$\pm 1.2$
		Angle	$\pm 0.5^\circ$

Internal Gears Data	
Class	JIS B 1702-1 grade NB
Reference section of gear	
Tooth Form	Standard full depth
Module	3
Pressure Angle	20°
No. of Teeth	50
Helix Angle & Hand	
Pitch Diameter	150
Addendum Modification	0
Addendum	3
Whole Depth	6.75
Outside Diameter	144
Thickness	59.67 $\pm 0.05$
Backlash	
Mating Gear	
Heat Treatment	
Induction Hardening	
Depth	
Remark	

SCM415			
Mark	Name	Matl.	Remarks
Drw. by	D.S	11. 10. 11	Title
Checked by	M.T	11. 10. 12	
Scale		1/1	
<b>KHK</b>			Dwg. No.
KOHARA GEAR INDUSTRY CO.,LTD			ABC002

### Rack Drawing

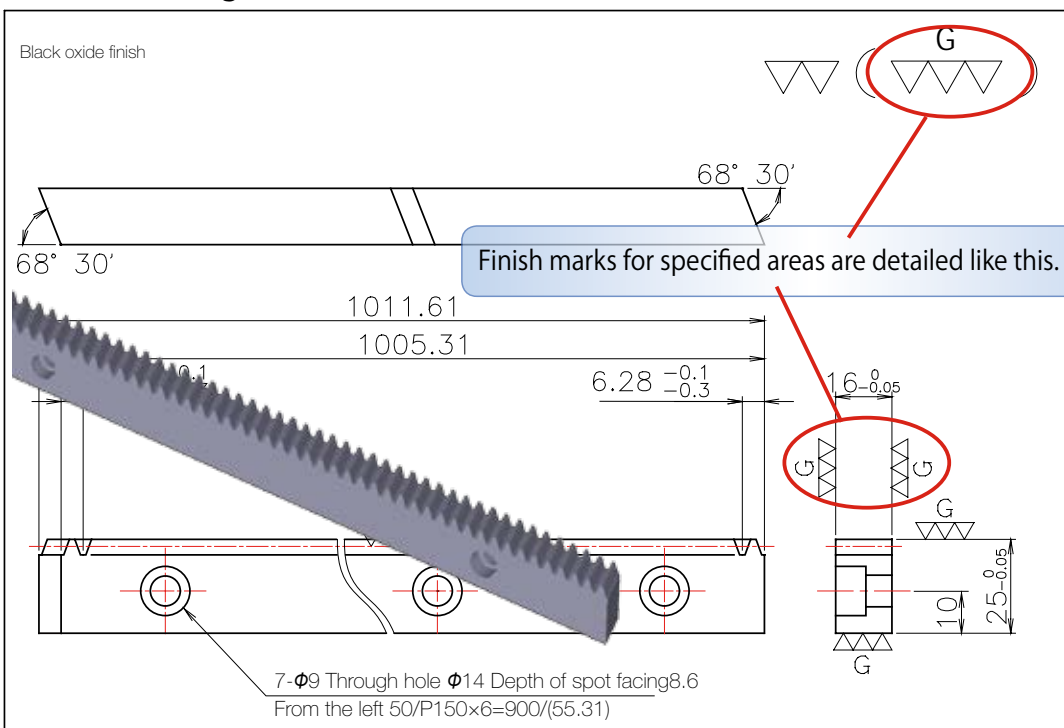

Roughness		Tolerance	
Sym.	Ra	Dimension & Up ~Max.	Tol. mm
$\sqrt{\text{Ra}}$	0.4a	0.5 ~ 6	$\pm 0.1$
$\sqrt{\text{Ra}}$	1.6a	6 ~ 30	$\pm 0.2$
$\nabla$	3.2a	30 ~ 120	$\pm 0.3$
$\nabla$	6.3a	120 ~ 400	$\pm 0.5$
$\nabla$	25a	400 ~ 1000	$\pm 0.8$
~		1000 ~ 2000	$\pm 1.2$
		Angle	$\pm 0.5^\circ$

Helical Racks Data	
Class	KHK R 001 grade 1
Reference section of gear	Rotating plane
Tooth Form	Standard full depth
Module	2
Pressure Angle	20°
No. of Teeth	160
Helix Angle & Hand	21°30'L
Pitch Diameter	23
Addendum Modification	0
Addendum	2
Whole Depth	4.5
Outside Diameter	25
Thickness	12.92 $\begin{matrix} 0 \\ -0.05 \end{matrix}$ ( 2.00 )
Backlash	
Mating Gear	
Heat Treatment	HB 250 ~ 285
Induction Hardening	
Remark	

SCM440			
Mark	Name	Matl.	Remarks
Drw. by	D.S	11. 10. 11	Title
Checked by	M.T	11. 10. 12	
Scale		1/1	
<b>KHK</b>			Dwg. No.
KOHARA GEAR INDUSTRY CO.,LTD			ABC003

For products having a non-symmetrical profile, such as helical racks with mounting holes, the product profile is described by 3 diagrams (angles), including a front view, side view, and a top view.

R0.6 Semi topping tooth profile  
 Normal pressure angle 18°42'30"  
 Straightness within 0.05/total length  
 Corners without designation are light chamfered

## Bevel Gear Drawing

Outer tip R2, Inter tip R1

Roughness		Tolerance	
Sym.	Ra	Dimension & Up ~Max.	Tol. mm
$\sqrt{\text{G}}$	0.4a	0.5 ~ 6	$\pm 0.1$
$\sqrt{\text{V}}$	1.6a	6 ~ 30	$\pm 0.2$
$\sqrt{\text{V}}$	3, 2a	30 ~ 120	$\pm 0.3$
$\sqrt{\text{V}}$	6, 3a	120 ~ 400	$\pm 0.5$
$\sqrt{\text{V}}$	25a	400 ~ 1000	$\pm 0.8$
~		1000 ~ 2000	$\pm 1.2$
		Angle	$\pm 0.5^\circ$

Spiral Bevel Gears Data	
Class	JIS B 1704 grade 4
Reference section of gear	Axial
Tooth Form	Gleason
Module	2.5
Pressure Angle	20°
No. of Teeth	20
Helix Angle & Hand	35° L
Pitch Diameter	50
Addendum Modification	0
Addendum	2.66
Whole Depth	4.72
Outside Diameter	54.43
Thickness	
Backlash	0.07 ~ 0.17
Mating Gear	30
Heat Treatment	
Induction Hardening	HRC 55-60
Depth	0.3 ~ 0.7
Remark	

Mark	Name	Matl.	Remarks
		SCM415	
Drw. by	D.S	11. 10. 11	Title
Checked by	M.T	11. 10. 12	
Scale	1/1		
<b>KHK</b>			Dwg. No.
KOHARA GEAR INDUSTRY CO.,LTD			ABC004

Roughness		Tolerance	
Sym.	Ra	Dimension & Up ~Max.	Tol. mm
$\sqrt{\text{G}}$	0.4a	0.5 ~ 6	$\pm 0.1$
$\sqrt{\text{V}}$	1.6a	6 ~ 30	$\pm 0.2$
$\sqrt{\text{V}}$	3, 2a	30 ~ 120	$\pm 0.3$
$\sqrt{\text{V}}$	6, 3a	120 ~ 400	$\pm 0.5$
$\sqrt{\text{V}}$	25a	400 ~ 1000	$\pm 0.8$
~		1000 ~ 2000	$\pm 1.2$
		Angle	$\pm 0.5^\circ$

Spiral Bevel Gears Data	
Class	JIS B 1704 grade 4
Reference section of gear	Axial
Tooth Form	Gleason
Module	2.5
Pressure Angle	20°
No. of Teeth	30
Helix Angle & Hand	35° R
Pitch Diameter	75
Addendum Modification	0
Addendum	1.57
Whole Depth	4.72
Outside Diameter	54.43
Thickness	
Backlash	0.07 ~ 0.17
Mating Gear	20
Heat Treatment	
Induction Hardening	HRC 55-60
Depth	0.3 ~ 0.7
Remark	

Mark	Name	Matl.	Remarks
		SCM415	
Drw. by	D.S	11. 10. 11	Title
Checked by	M.T	11. 10. 12	
Scale	1/1		
<b>KHK</b>			Dwg. No.
KOHARA GEAR INDUSTRY CO.,LTD			ABC005

Worm Gear Pair Drawing

Black oxide finish  
Straightened & annealed after therm...

Special notes must be written in words, and in detail.

Specify geometric tolerances in the area that requires runout accuracy.

Symbol for Chamfer angles C1, C2... are set to 45 degree. To request other angles, specify the angle and the dimension.

The area (face) where heat treatment is applied must be specified clearly.

Roughness		Tolerance	
Sym.	Ra	Dimension & Up ~Max.	Tol. mm
$\sqrt{\text{Ra}}$	0.4a	0.5 ~ 6	$\pm 0.1$
$\sqrt{\text{Rz}}$	1.6a	6 ~ 30	$\pm 0.2$
$\nabla$	3.2a	30 ~ 120	$\pm 0.3$
$\nabla$	6.3a	120 ~ 400	$\pm 0.5$
$\nabla$	25a	400 ~ 1000	$\pm 0.8$
$\sim$		1000 ~ 2000	$\pm 1.2$
		Angle	$\pm 0.5^\circ$

Worms Data	
Class	KHK W 001 grade 2
Reference section of gear	Axial
Tooth Form	JIS 3 type
Module	2
Pressure Angle	20° 30'
No. of Teeth	2 the number of threads
Lead Angle & Hand	10° 20' R
Pitch Diameter	22
Addendum Modification	0
Addendum	2
Whole Depth	4.5
Outside Diameter	26
Thickness	3.10 $\frac{+0.07}{-0.12}$ ( 2.00 )
Backlash	
Mating Gear	
Heat Treatment	HB 225-260
Induction Hardening	HRC 45 ~ 55
Remark	

Mark	Name	Matl.	Remarks
		SCM440	
Drw. by	D.S	11. 10. 11	Title
Checked by	M.T	11. 10. 12	
Scale	1/1		
<b>KHK</b>			Dwg. No.
KOHARA GEAR INDUSTRY CO., LTD			ABC006

This is the throat diameter, equal to the tip diameter for helical gears.

Tip diameter is to be set optionally, but should be set as "throat diameter + module"  $\pm 0.015$

Specify the mounting distance when the worm wheel is set up with the mating worm. This dimension is used as the basis when producing the gears.

Roughness		Tolerance	
Sym.	Ra	Dimension & Up ~Max.	Tol. mm
$\sqrt{\text{Ra}}$	0.4a	0.5 ~ 6	$\pm 0.1$
$\sqrt{\text{Rz}}$	1.6a	6 ~ 30	$\pm 0.2$
$\nabla$	3.2a	30 ~ 120	$\pm 0.3$
$\nabla$	6.3a	120 ~ 400	$\pm 0.5$
$\nabla$	25a	400 ~ 1000	$\pm 0.8$
$\sim$		1000 ~ 2000	$\pm 1.2$
		Angle	$\pm 0.5^\circ$

Worms Data	
Class	KHK W002 grade 2
Reference section of gear	Rotating plane
Tooth Form	Standard full depth
Module	2
Pressure Angle	20°
No. of Teeth	20
Helix Angle & Hand	7° 21' R
Pitch Diameter	40
Addendum Modification	0
Addendum	2
Whole Depth	4.5
Outside Diameter	46
Thickness	
Backlash	0.14 ~ 0.21

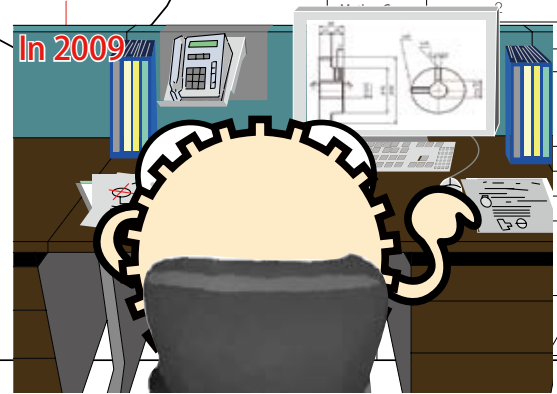

### 3 - 2 Design Aids for Gear Drawing

KHK provides an easy and quick-to-use automatic drawing system that allows you to create gear drawings by inputting essential data. Even beginners can create gear drawings instantly, so go ahead and try it out!

#### ■ Drawing assistance for applying modifications to KHK Stock Gears

**KHK Web Catalog [www.khkgears.co.jp/en/web\\_catalog/](http://www.khkgears.co.jp/en/web_catalog/)**

Many of KHK Stock Gears are provided with non-threaded holes, so secondary operations can be applied according to your specifications. The drawing assistance system for modifications is available in the KHK Web Catalog and the CD Catalog. We hope you will make the best use of our drawing assistant, which is frequently used by many people.

**Modification System**

Catalog No.	Module	No. of teeth	Shape	Bore	Hub dia.	Pitch dia.	Outside dia.	Face width	Hub Width	Total length	Web thickness	Flm O.D.	Key width	Key dept.
SS1-19	1	19	S3	8	21	19	21	10	20	30				
SS1-19A	1	19	S3T	8	21	19	21	10	20	30				
SS1-20	1	20	S1	8	16	20	20	10	10	20				
SS1-20A	1	20	S1T	5	16	20	20	10	10	20				

● Select a product, then, click on "Drawing display / Create drawings for modification".

**Modifications input**

- Class: JS B1702-1 grade NB
- Teeth Form: Standard full depth
- Module: 1
- Pressure Angle: 20°
- Number of Teeth: 20
- Pitch Diameter: 20
- Addendum: 1
- Whole Depth: 2.25
- Outside Diameter: 22
- Surface hardness: less than HB24
- Material: S45C
- Surface finish: Cut
- Datum reference surface for teeth cutting: Bore (H7)

**3D CAD External Link**

3D CAD Data can be outputted.

● Click on "Modifications input"

**Drawing**

● Click on "Drawing"

● Save the data for print-out, or as CAD data.

**DXF Data**

**Print**

**■ Drawing Assistance for Custom Gears**

Automatic drawing system for Custom Gears [www.khkgears.co.jp/khkweb/order/main.do?lang=en](http://www.khkgears.co.jp/khkweb/order/main.do?lang=en)

Quick and easy. Use of this drawing system allows you to create drawings in accordance with the specifications you require. Functions for dimension calculation and outputting of DXF data are also available. For strength calculations, we provide a calculation software, "GCSW for Web" (User registration is required for use).

GCSW : Gear Calculation Software for Web [www.khkgears.co.jp/en/gear\\_technology/gcswforweb.html](http://www.khkgears.co.jp/en/gear_technology/gcswforweb.html)

\* The drawing of each gear can be created only for basic forms.

**Spur / Helical Gears**

**Internal Gears**

**Miter / Bevel Gears**

**Racks**

**Worm Gear Pair**

**Screw Gears**

**Custom Gears Drawing System**

\*\* Please note there may be cases that gears with the profiles drawn with this function cannot be practically produced.

# 4. Gear Installment and Lubrication

Improper installment or bad lubrication of gears can create problems. Here, we introduce correct gear installments and selection of appropriate lubrications.

## 4 - 1 Installment of Gears and Confirmation

Since gears are rotational parts, they must be installed to shafts firmly, with consideration of safety concerns. Also, you should be careful in not letting the gear move in an axial direction, due to the axial thrust forces being produced, that is determined by the gear profile, or the helix hand. Secure ways of gear installment and confirmation methods are introduced here.

### ■ Spur Gears

Spur gears produce no axial thrust forces, however, it is still very important to mount gears to shafts firmly. The installment has to be done so that the gear flank never makes contact with the bearing frame while the gear is rotating. If this condition occurs at the area where the gear teeth make contact with those of the mating gear, it will influence durability. Thus, proper positioning is essential. The following numbered items from ① to ⑦ show the order of installation for attaching spur gears to a frame.

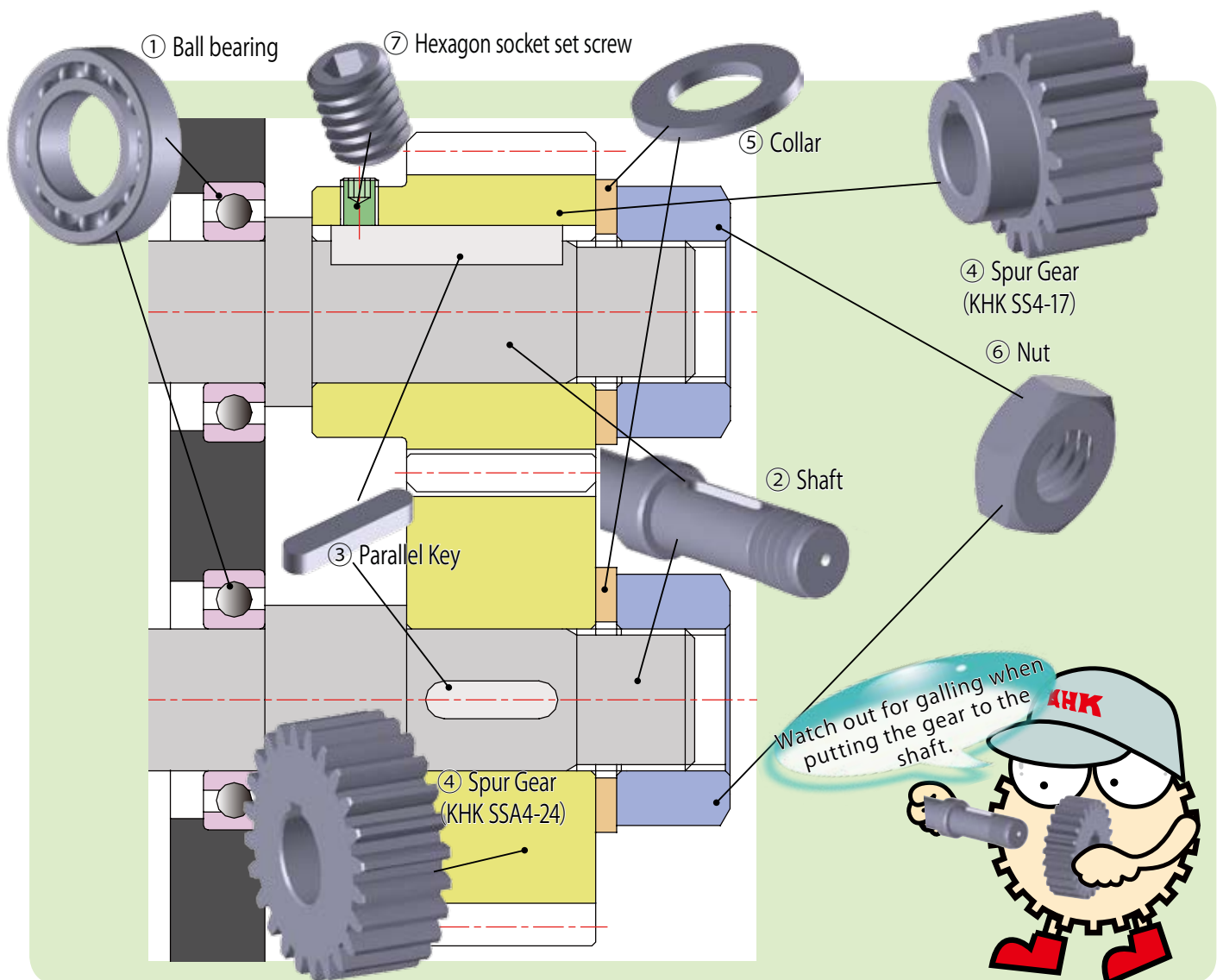

\* Before gear installment, be sure to read "4-4 Safety Considerations and Precautions in Starting Operations" on page 35.

## Racks & Pinions

Since Rack and Pinion Gears are used for linear motion, it is important to assemble the mounting distance ( $a$ ) of the rack and the pinion, to maintain accuracy at any position. Also, uneven contact of gear teeth must be avoided as the pinion is mounted to the bearing with cantilever support.

The following numbered items from ① to ④ show the order of installation of attaching a rack to a frame.

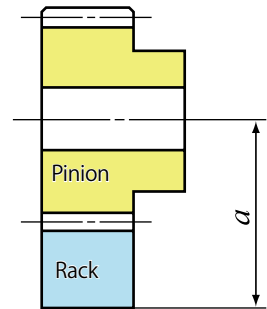

③ Move (stroke) the pinion on the overall rack to check backlash or tooth contacts, and then adjust for proper installment. Especially important in maintaining accuracy at connected parts.

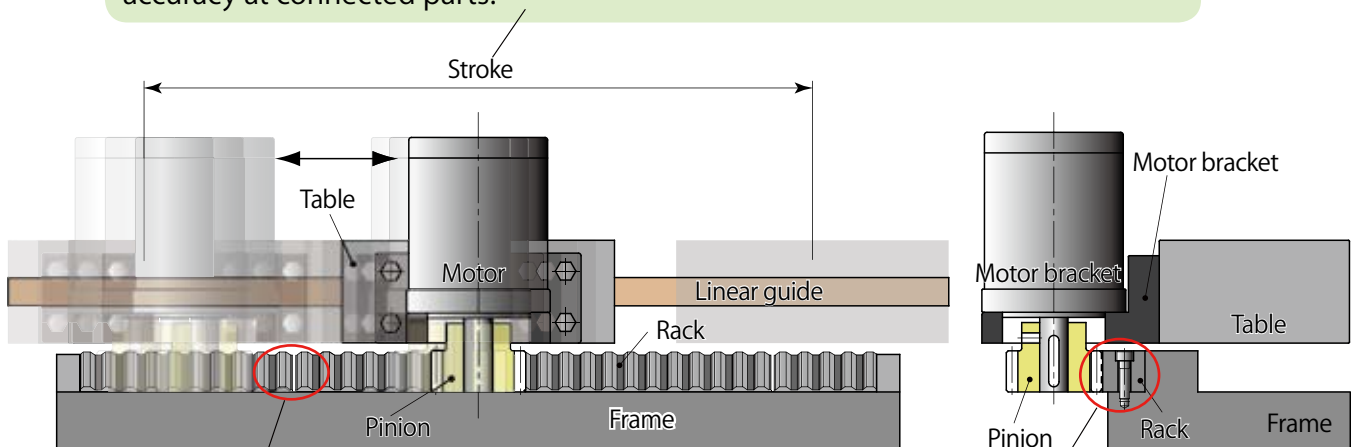

② When using several racks in connection, be sure to set accurate pitch at the mating ends. Use of adjoining gauge racks is convenient in this usage.

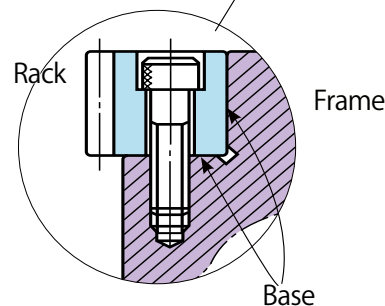
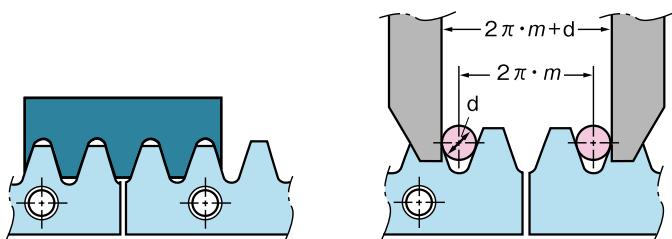

① Attach the rack to the base of the frame tightly and then fix the hexagon socket bolt temporarily.

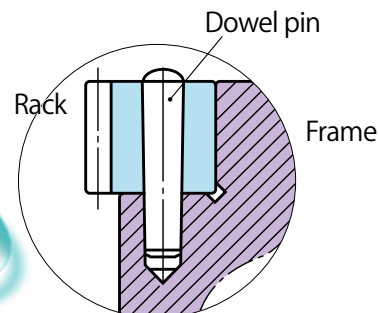
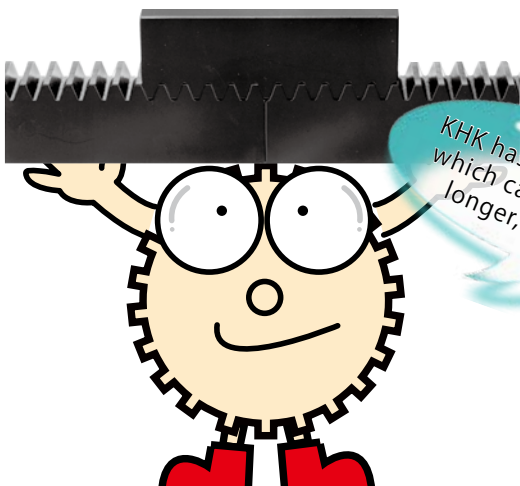

④ Determine the accurate position, fix with dowel pins, then make a final tightening of the hexagon socket bolt, so that the rack will not go out of position.

## ■ Bevel Gears

Since bevel gears are used in intersecting axis, where input shaft and output shaft are crossed at a point, bevel gears are used with support on one end, in many cases. In this case, the shaft should be made as thick as possible to encourage stiffness, and the bearing should be set as close as possible, to prevent deflection of the shaft.

Also, bevel gears produce axial thrust forces (thrust) due to its conical profile. For spiral gears, it is especially important to select proper bearings by calculating the thrust, as the thrust varies depending on the rotational direction and helix hands.

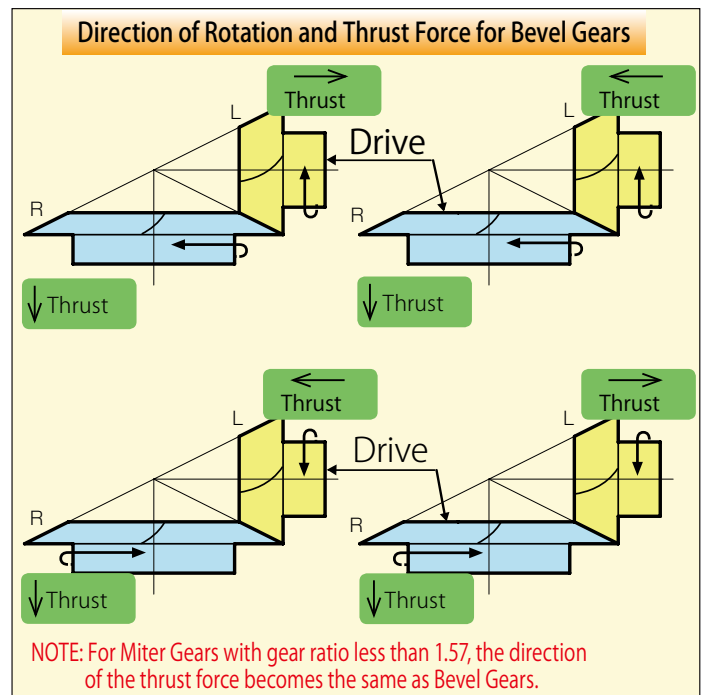
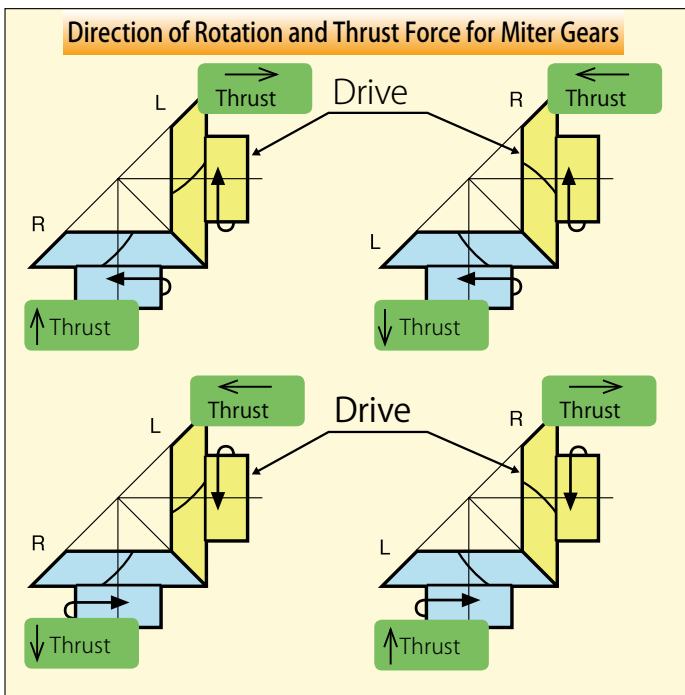
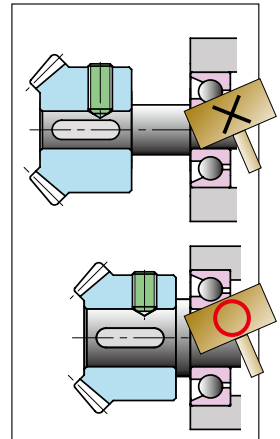

● Installment example for bevel gears mounted by using angular contact ball bearings.

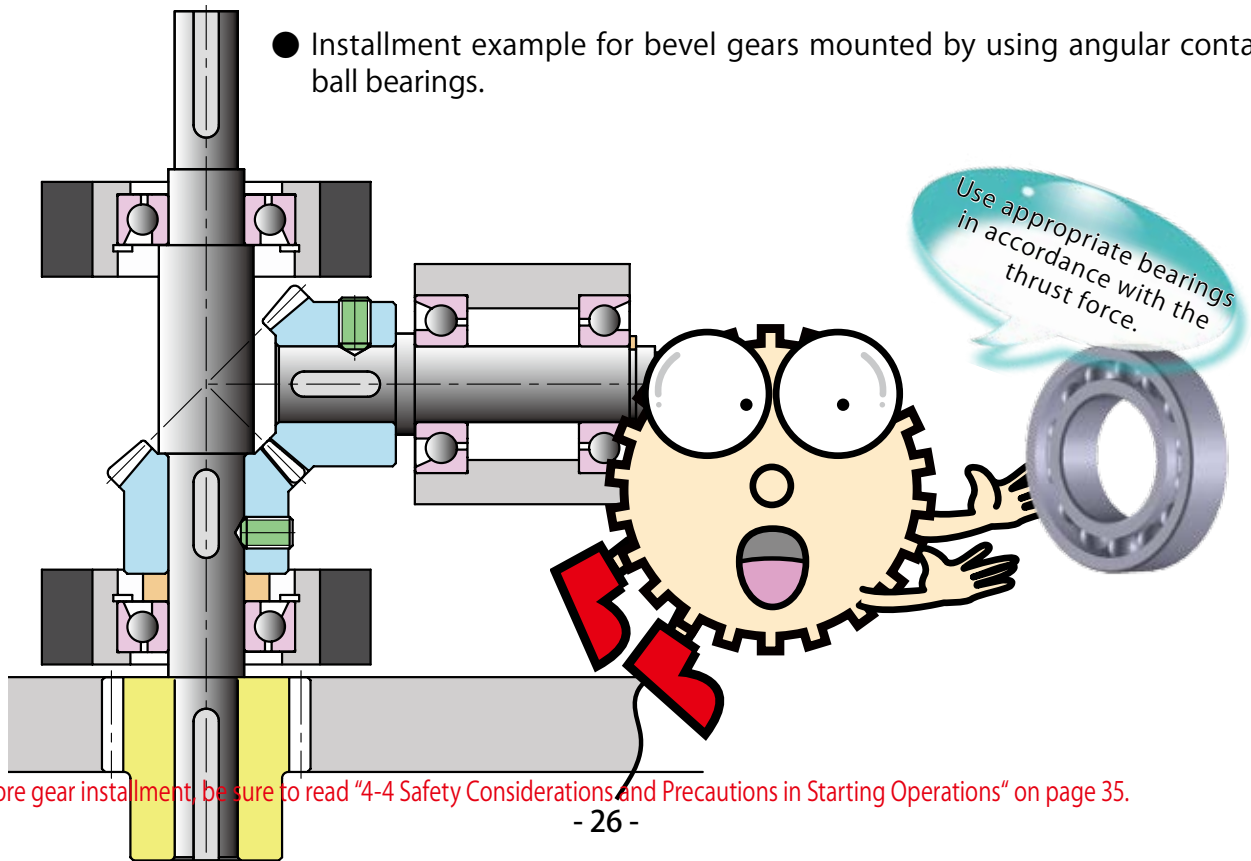

\* Before gear installment, be sure to read "4-4 Safety Considerations and Precautions in Starting Operations" on page 35.

When installing Bevel Gears, it is essential to make sure of the tooth contact. The state of the tooth contact will show deviations, including mounting distance errors, offset errors, and shaft angle errors. As inaccurate assembly will lead to irregular noises and uneven wear, you need to adjust the mounting position when installing.

### Correct Tooth Contact

- When assembled correctly, the contact will occur on both gears in the middle of the flank and center of face width but somewhat closer to the toe.

Center contact closer to toes

### Incorrect Tooth Contact

#### Mounting Distance Error

- When the mounting distance of the pinion is incorrect, the contact will occur too high on the flank on one gear and too low on the other.

#### Offset Error

- When the pinion shaft is offset, the contact surface is near the toe of one gear and near the heel on the other.

#### Shaft Angle Error

- When there is an angular error of shafts, the gears will contact at the toes or heels depending on whether the angle is greater or less than 90°.

### Measurement of Backlash

As the photo below shows, backlash is measured by holding one gear and applying a dial gauge vertically. If the gears are installed in a sealed place, the backlash of the shaft angle can be measured by holding one of the shafts, either the output shaft or the input shaft.

### KHK KBX Bevel Gearboxes

Backlash can be measured from the shaft angle too.

## Worm Gear Pair

Due to the helix of the gear tooth, worms and worm wheels produce axial thrust forces. Use appropriate bearings in accordance with the calculations for thrust forces.

With large thrust force acting on worms, it is important that they are secured to the shaft firmly. Use thrust bearings or tapered-roller-bearings to avoid shifting of the shaft in the thrust direction.

Mistakes made in the selection of bearings, or a mistake made in the assembling of worm gears cause abnormal wear or other unexpected troubles.

The illustration below shows an example of a worm gear pair assembled with tapered-roller-bearings

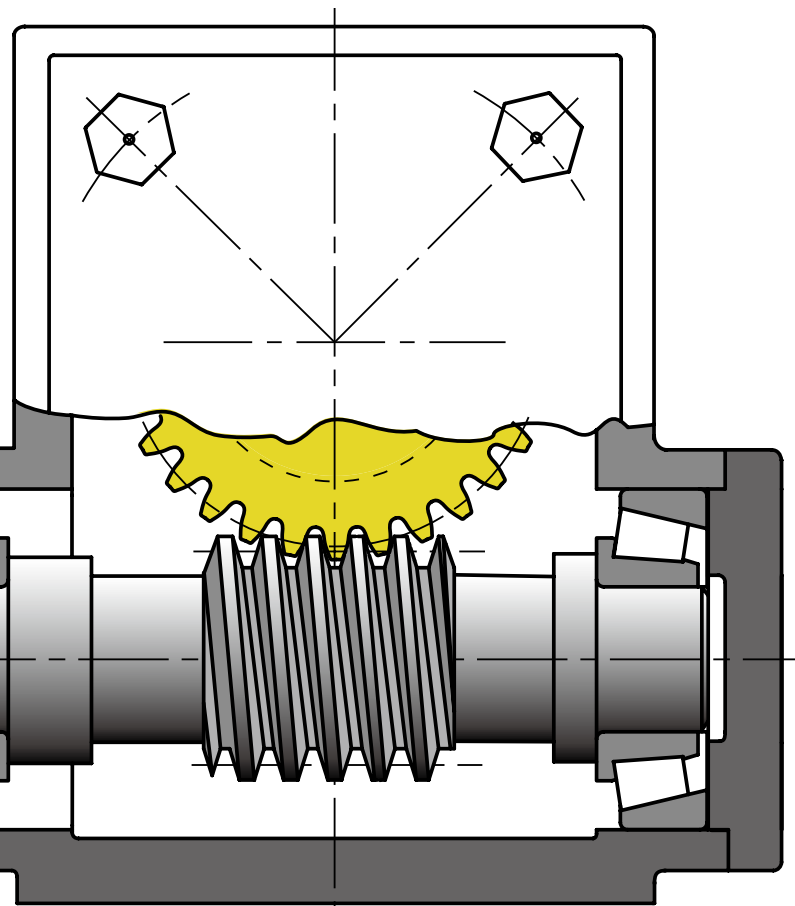
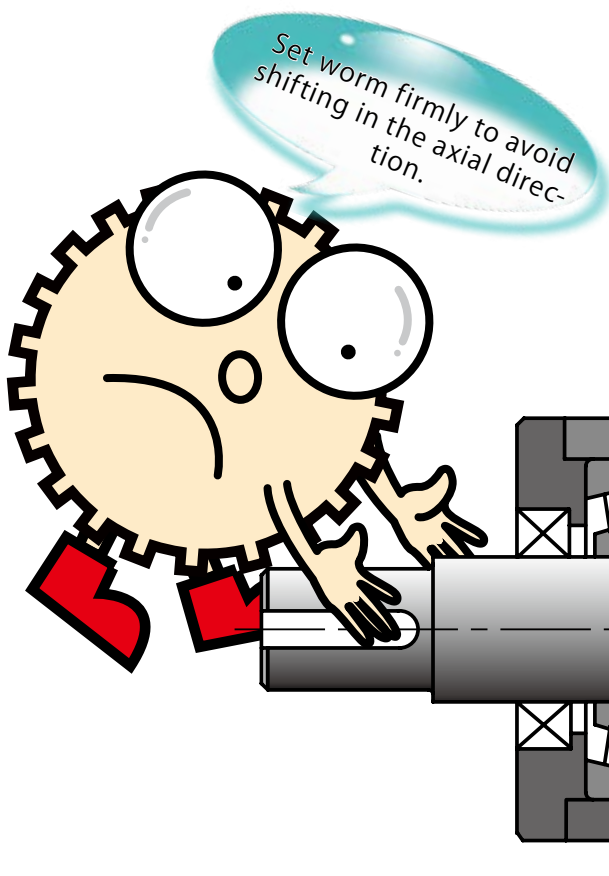
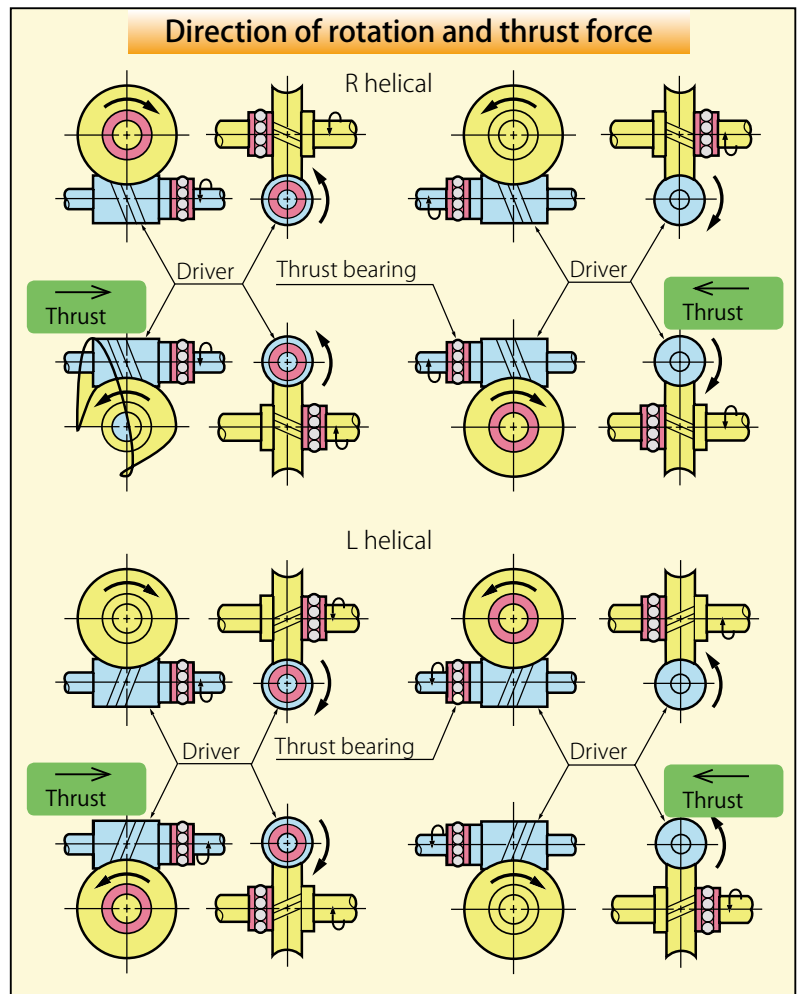

\* Before gear installment, be sure to read "4-4 Safety Considerations and Precautions in Starting Operations" on page 35.

When assembling a worm gear pair, be sure to check the tooth contact and backlash. How well the worms and worm wheels are assembled has a large effect on the friction of the unit. The tooth contact and backlash at the time of assembly must be checked for correctness, as shown below.

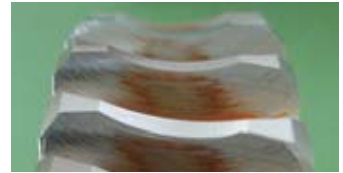

**Tooth Contact of a Worm Gear Pair**

- Verify that the worm axis is perpendicular to the worm wheel axis.

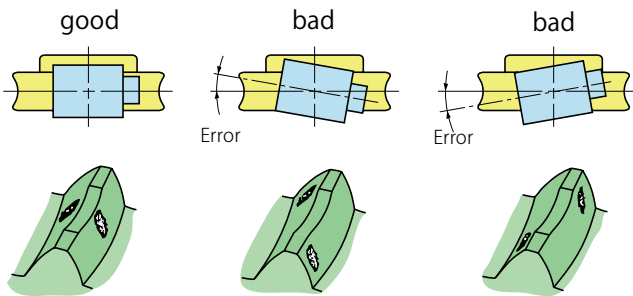

- Check that the worm axis is in the center of the worm wheel face width.

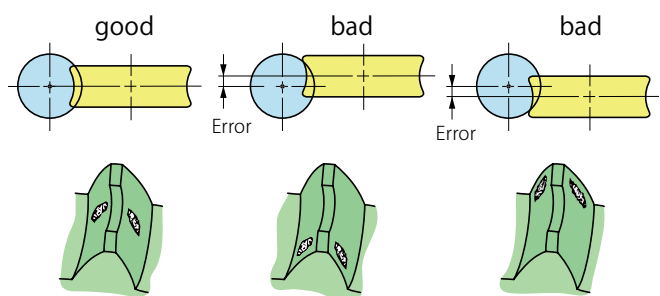

- Check the mounting distance (allowable mounting distance from H7 to H8).

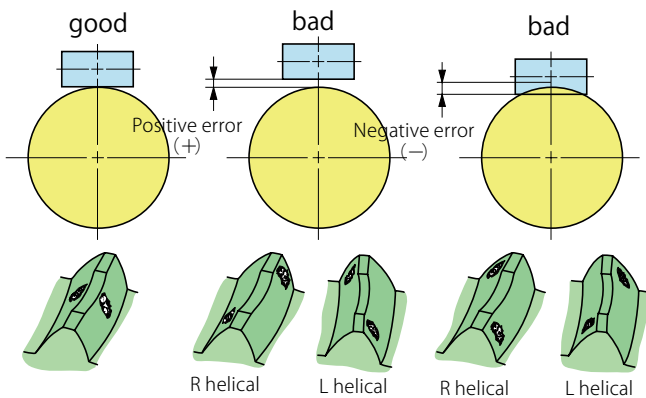

- Confirm that the center of the worm wheel goes through the midpoint of the worm length.

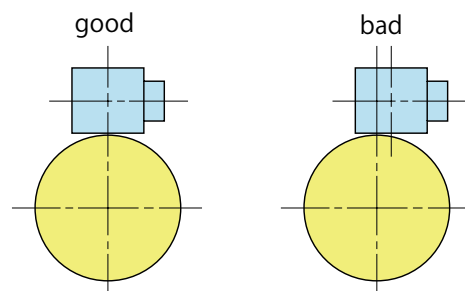

The worm wheel cannot rotate correctly if the worm is engaged close to either end of its length.

**Measurement of Backlash**

As the photo below shows, backlash is measured by applying a dial test indicator at the contact tooth and measuring the runout. If the worm gear pair is in a sealed place, the backlash can also be performed by measuring the angular backlash of input and output shafts.

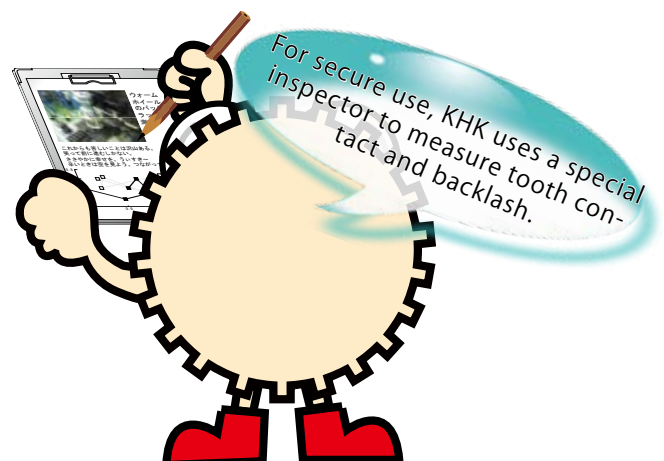

## 4 - 2 Lubrication of Gears

How well lubrication is applied has a large effect on the durability and the level of noise. Except for using plastic gears in specific conditions, lubrication must be applied properly. There are three gear lubrication methods in general use.

- ( 1 ) Grease lubrication
- ( 2 ) Splash lubrication (oil bath method)
- ( 3 ) Forced oil circulation lubrication

A lubrication method is basically selected depending on tangential speed (m / s) and rotating speed (rpm). Generally, grease lubrication is used with low speed, For medium speed, splash lubrication is appropriate. For high speed, forced oil circulation lubrication is used. However, these choices are only used as a guide and there are exceptions. Sometimes, for maintenance reasons, a grease lubricant is used even with high speed.



● Ranges of tangential speed (m/s) for spur and bevel gears

No.	Lubrication	Range of tangential speed $v_t$ (m/s)					
		0	5	10	15	20	25
1	Grease lubrication	←→					
2	Splash lubrication	←→					
3	Forced oil circulation lubrication						←

● Range of sliding speed (m/s) for worm wheels

No.	Lubrication	Range of tangential speed $v_s$ (m/s)					
		0	5	10	15	20	25
1	Grease lubrication	←→					
2	Splash lubrication	←→					
3	Forced oil circulation lubrication						←

### ■ Grease Lubrication

Grease lubrication is suitable for any gear system that is open or enclosed, so long as it runs at low speed and with light load. When applying grease lubrication, the following points must be considered carefully.

◎ Choosing a lubricant with suitable cone penetration

A lubricant that is fluid is especially effective in enclosed systems. For open systems, the use of grease with adequate consistency and adherence is recommended.

◎ Not suitable for use under high load and continuous operation

The cooling effect of grease is not as good as lubricating oil. So it may become a problem with temperature rise under high load and continuous operation conditions.

◎ Proper quantity of grease

There must be sufficient grease to do the job. However, too much grease can be harmful, particularly in an enclosed system. Excess grease will cause agitation, viscous drag and result in power loss.

**■ Splash Lubrication (Oil bath method)**

Splash lubrication is used with an enclosed system. The rotating gears splash lubricant onto the gear system and bearings. When applying splash lubrication, the following points must be considered carefully.

☉ Appropriate oil level

There will be excess agitation loss if the oil level is too high. On the other hand, there will not be effective lubrication or ability to cool the gears if the level is too low. Use the data in the table below as reference and adjust the oil level accordingly.

☉ Temperature limitation

The temperature of a gear system may rise because of friction loss due to gears bearings and lubricant agitation. Rising temperature may cause problems as the viscosity of lubricant decreases. As a rule, the temperature limitation that the lubricants can withstand will be between 80°C to 90°C .

● Adequate oil level

Type of gears	Spur gears and helical gears		Bevel gears	Worm gear pair	
Gear orientation	Horizontal shaft	Vertical shaft	(Horizontal shaft)	Worm - above	Worm - below
Oil level					

Where :  $h$  = Tooth depth,  $b$  = Face width,  $d_2$  = Reference diameter of worm wheel,  $d_1$  = Reference diameter of worm

**■ Forced Oil Circulation Lubrication**

Forced oil circulation lubrication applies lubricant to the contact portion of the teeth by means of an oil pump. There are drop, spray and oil mist methods of application.

[ Drop Method ]

An oil pump is used to suck-up the lubricant and then directly drop it on the contact portion of the gears via a delivery pipe.

[ Spray Method ]

An oil pump is used to spray the lubricant directly on the contact area of the gears.

[ Oil Mist Method ]

Lubricant is mixed with compressed air to form an oil mist that is sprayed against the contact region of the gears.

Oil tank, pump, filter, piping and other devices are needed in the forced oil lubrication system. Therefore, it is used only for special high-speed or large gear box applications. By filtering and cooling the circulating lubricant, the right viscosity and cleanliness can be maintained. This is considered to be the best way to lubricate gears.

## 4 - 3 Selecting Lubricant Methods

To make metal gears transmit power efficiently, an oil film must be formed at the contact surface of the teeth to minimize friction and to prevent dry metal-to-metal contact. The lubricant should have the properties listed in the table below.

● The properties that lubricant should possess

Properties	Description
Correct and proper viscosity	Lubrication should maintain proper viscosity to form a stable oil film at the specified temperature and speed of operation.
Antiscoring property	Lubricant should have the property to prevent the scoring failure of tooth surface while under high-pressure of load.
Oxidization and heat stability	A good lubricant should not oxidize easily and must perform in moist and high-temperature environment for long duration.
Water anti-affinity property	Moisture tends to condense due to temperature change when the gears are stopped. The lubricant should have the property of isolating moisture and water from lubricant.
Antifoam property	If the lubricant foams under agitation, it will not provide a good oil film. Antifoam property is a vital requirement.
Anticorrosion property	Lubrication should be neutral and stable to prevent corrosion from rust that may mix into the oil.

■ Types of Lubricants and Usage

The correct viscosity is the most important consideration in choosing a proper lubricant. Using reference JIS K 2219: 1993, gear oils are categorized into 2 types for industrial use, according to the viscosity grade. Refer to these classifications to find the range for the Kinematic viscosity of lubricant.

● Types of Gear Oils and the Usage

Type	ISO Viscosity Grade	Kinematic Viscosity Center Value $10^{-6}m^2/s$ (cSt) (40°C)	Usage
1	ISO VG 32	32	Mostly used for lightly loaded enclosed-gears in general type of machines.
	ISO VG 46	46	
	ISO VG 68	68	
	ISO VG 100	100	
	ISO VG 150	150	
	ISO VG 220	220	
	ISO VG 320	320	
2	ISO VG 460	460	Mostly used for middle or heavily loaded enclosed-gears in general types of machines or rolling machines.
	ISO VG 68	68	
	ISO VG 100	100	
	ISO VG 150	150	
	ISO VG 220	220	
	ISO VG 320	320	
	ISO VG 460	460	
	ISO VG 680	680	

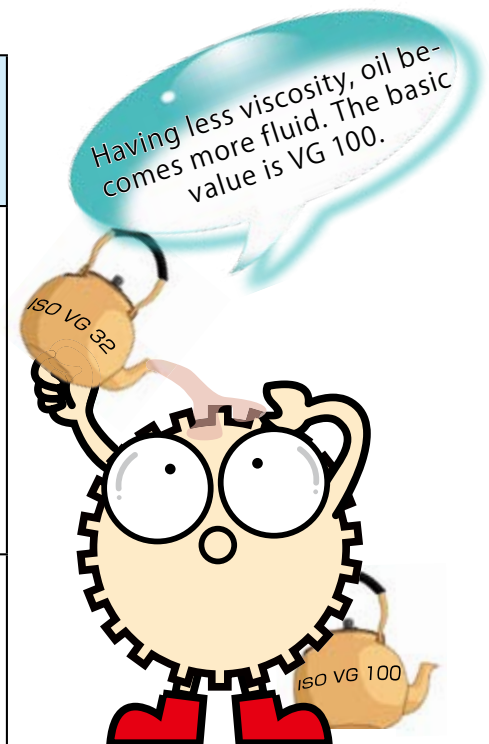

## ■ Proper Viscosity for Lubricant

It is practical to select a lubricant by following the information from JIS, JGMA and AGMA standards, or information from the oil manufacturer. The table below shows the proper viscosity for enclosed-gears, recommended by the oil manufacturer.

### ● Recommended Viscosity for Enclosed Gears

Rotation of Pinion (rpm)	Horsepower(PS)	Reduction Ratio below 10		Reduction Ratio over 10	
		cSt (40°C)	ISO Viscosity Grade	cSt (40°C)	ISO Viscosity Grade
Less than 300	Less than 30	5 ~ 234	150, 220	180 ~ 279	220
	30 to 100	180 ~ 279	220	216 ~ 360	220,320
	More than 100	279 ~ 378	320	360 ~ 522	460
300 ∩ 1,000	Less than 20	81 ~ 153	100,150	117 ~ 198	150
	20 to 75	117 ~ 198	150	180 ~ 279	220
	More than 75	180 ~ 279	220	279 ~ 378	320
1,000 ∩ 2,000	Less than 10	54 ~ 117	68,100	59 ~ 153	68,100,150
	10 to 50	59 ~ 153	68,100,150	135 ~ 198	150
	More than 50	135 ~ 198	150	189 ~ 342	220,320
2,000 ∩ 5,000	Less than 5	27 ~ 36	32	41 ~ 63	46
	5 to 20	41 ~ 63	46	59 ~ 144	68,100
	More than 20	59 ~ 144	68,100	95 ~ 153	100,150
More than 5000	Less than 1	9 ~ 31	10,15,22	18 ~ 32	22,32
	1 to 10	18 ~ 32	22,32	29 ~ 63	32,46
	More than 10	29 ~ 63	32,46	41 ~ 63	46

NOTE 1 : Applicable for spur, helical, bevel and spiral bevel gears.

NOTE 2 : The working temperature (oil temperature) conditions should be between 10 and 50°C .

## ■ Selection of Lubricants for the Worm Gear Pair

Unlike spur or bevel gears, a worm gear pair gets slippage at the tooth contact, so oil manufacturers provide "Worm Gear Oils" suitable to use for a worm gear pair.

The table on the right indicates reference values for proper viscosity, recommended in accordance with strength calculations (JGMA405-01 (1978)).

Determine adequate oil viscosity from oil temperature at working and slip speeds, then, check the brand of lubricants from product information offered by oil manufacturers.

### ● Reference Viscosity for Worm Gear Lubrication Unit:cSt(37.8°C)

Oil Temperature at Working		Slip Speed m/s		
Max Oil Temperature at Working	Start oil temperature	Less than 2.5	Over 2.5 less than 5	Over 5
Over 0°C Below 10°C	— Over 10°C Below 0°C	110 ~ 130	110 ~ 130	110 ~ 130
	Over 0°C	110 ~ 150	110 ~ 150	110 ~ 150
Over 10°C Below 30°C	Over 0°C	200 ~ 245	150 ~ 200	150 ~ 200
Over 30°C Below 55°C	Over 0°C	350 ~ 510	245 ~ 350	200 ~ 245
Over 55°C Below 80°C	Over 0°C	510 ~ 780	350 ~ 510	245 ~ 350
Over 80°C Below 100°C	Over 0°C	900 ~ 1100	510 ~ 780	350 ~ 510

### Consistency Numbers for Greases

Consistency is a technical word to express viscosity of lubricants, which indicates hardness / softness of the pasty substances and fluidity. Grease consistency is identified by consistency numbers (NLGI No. \*) ranging from 000 to 6. The table on the right shows consistency numbers and each of segmented range including the state. Use as reference to consider what grease to use.

\* NLGI No. denotes Consistency Numbers defined by National Lubricating Grease Institute (NLGI).

### Grease Type

NLGI No.	Worked penetration (1/10 mm)	State
000	445 ~ 475	Semi-fluid
00	400 ~ 430	Semi-fluid
0	355 ~ 385	Very Soft
1	310 ~ 340	Soft
2	265 ~ 295	Medium
3	220 ~ 250	Semi-Solid
4	175 ~ 205	Solid
5	130 ~ 160	Very Hard
6	85 ~ 115	Very Hard

### Selecting Grease

Grease is sorted into 7 categories and segmented by types (components and properties). The table below contains information on 4 types of grease, categorized by usage (excerpted from JIS K 2220:2003). Consistency is important in selecting grease. Use the application examples as reference to select a proper grease.

### Grease Types and Application Examples

Type			Operating Temperature Limit °C	Reference				Application Examples
Usage	Class	Consistency Numbers		Adequacy of Use			With water	
				Load				
				Low	High	Impact		
General use Grease	1	1, 2, 3, 4	-10 ~ 60	S	N	N	S	General usage in low loads
	2	2, 3	-10 ~ 100	S	N	N	N	General usage in medium loads
Grease in centralized lubrication	1	00, 0, 1	-10 ~ 60	S	N	N	S	Centralized lubricating system for medium loads
	2	0, 1, 2	-10 ~ 100	S	N	N	S	
	3	0, 1, 2	-10 ~ 60	S	S	S	S	
	4	0, 1, 2	-10 ~ 100	S	S	S	S	
High load grease	1	0, 1, 2, 3	-10 ~ 100	S	S	S	S	Use in high/ impact loads
Grease for gear compound	1	1 <sup>NOTE1</sup> , 2 <sup>NOTE1</sup> , 3 <sup>NOTE1</sup>	-10 ~ 100	S	S	S	S	Use for open gears / wire

NOTE1: Consistency numbers are classified by viscosity.

S: Suitable N: Not Suitable

## 4 - 4 Safety Considerations and Precautions in Starting Operations

Since many gear products are heavy, mostly made of steel, it is necessary to give your full attention when handling and assembling gears. Gears are transmission components that work by meshing with rotational or linear motion components to transmit power, so safety should always be the first priority when starting operations.

### ■ Safety Considerations

Follow all applicable safety regulations (Labor, Safety, and Sanitation Regulations) in installing and operating gear products.

#### ● Handle with Care

- Gears should be handled carefully, as the edges are sharp and dangerous.
- To transport heavy gear products, use a lift or a crane.
- Avoid dropping or hitting gears.
- If gears are stored for a long period of time, look for deteriorations, such as rust.

#### ● Precautions in Assembling

- If the gear is exposed, install a safety cover for protection.
- Turn off the power.
- Never put any part of your body under installed gears.
- Wear proper attire and protective gear appropriate for the task.

### ■ Precautions in Starting Operations

For starting operations of gear devices, it is important to make confirmations; before, during and after starting operations. All necessary checks must be done before starting, if something abnormal is detected while operating or after operation, proper treatments should be implemented.

#### ● Before operating, check the following:

- Are the gears firmly mounted on the shafts?
- Does the gear mesh have a proper amount of backlash?
- Is there sufficient lubrication?



#### ● While operating, check the following:

- Is there unusual noise?
- Is there unusual vibration?
- Is there oil-spilling or grease scattering?

#### ● After operating, check the following:

- Is there looseness of the gear?
- Is there contamination in the lubricant?
- Does the device have abnormal heat?

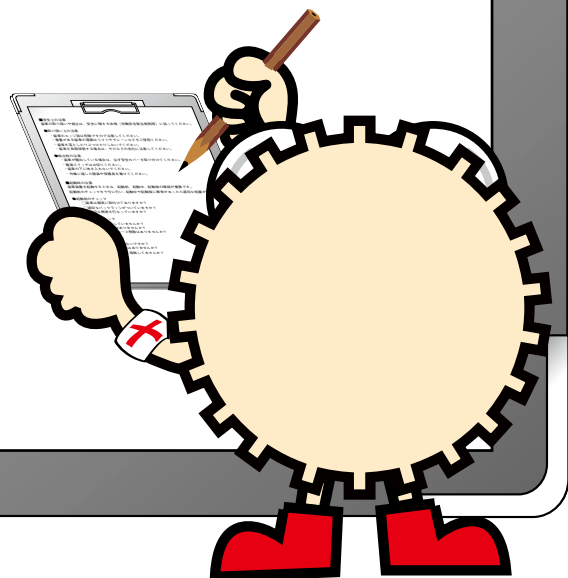

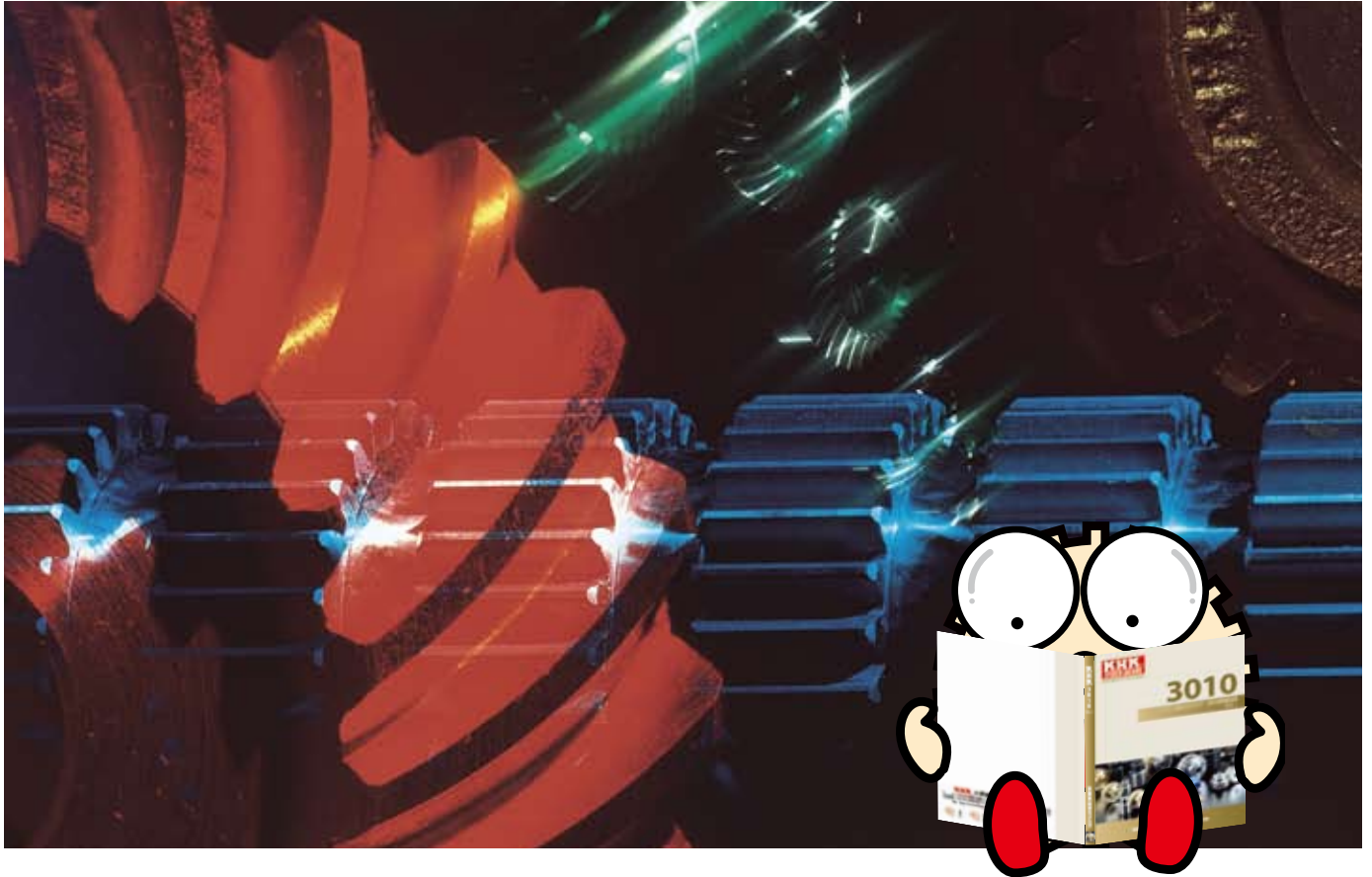

- All rights reserved herein and no portion of this booklet may be reproduced without the prior consent in writing from KHK Co.,Ltd.
- This booklet is published for the purpose of informing people about gears and is used as a KHK's sales promotion advertisement.
- No guarantee is given by KHK Co.,Ltd. on the contents of these copyrighted works. Please note that, even if there are errors therein, we shall not be held responsible, whatsoever.
- KHK Co.,Ltd. reserves the right to make changes to the specifications and contents of this booklet, without notice.

---

# The ABC's of Gears Guide for Practical Use - C

March 15, 2010 First Published

Copyright by Kohara Gear Industry Co.,Ltd.  
All rights reserved.

Publisher Toshiharu Kohara

Published by Kohara Gear Industry Co.,Ltd.

13-17 Naka-cho, Kawaguchi-shi, Saitama-ken, 332-0022 Japan

Editor / Producer Team ABC's of Gears



**KHK**<sup>®</sup>

***KOHARA GEAR INDUSTRY CO., LTD.***

13-15 Nakacho, Kowaguchi-shi, Saitama-ken, 332-0022 Japan TEL:048-254-1744 Fax:048-254-1765

URL <http://www.khkgears.co.jp/en/>

E-mail [export@khkgears.co.jp](mailto:export@khkgears.co.jp)