

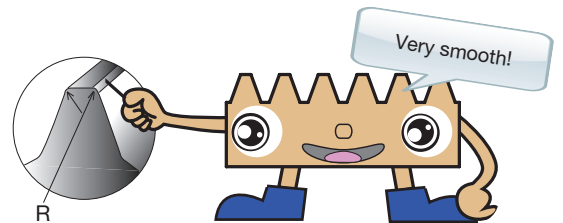

CP Racks & Pinions

KTSCP <small>[CP] Tapered Pinions</small>  Material: SCM440 CP5, 10 Page 278	STRCPF/STRCPFD <small>[CP] Tapered Racks</small>  Material: S45C CP5, 10 Page 278	MSCPG <small>[CP] Ground Spur Gears</small>  Material: SCM415 CP5, 10 Page 280	MRGCPF/MRGCPFD <small>[CP] Hardened Ground Racks</small>  Material: SCM415 CP5, 10 Page 280	KSCPG <small>[CP] Ground Spur Gears</small>  Material: SCM440 CP5, 10 Page 282	KRGCPF-H/KRGCPFD-H <small>[CP] Hardened Ground Racks</small>  Material: SCM440 CP5, 10 Page 282	KRGCP/KRGCPF/KRGCPFD <small>[CP] Thermal Refined Ground Rack</small>  Material: SCM440 CP5, 10 Page 284	SSCPGS <small>[CP] Ground Spur Pinion Shafts</small>  Material: S45C CP5, 10 Page 286
SSCPG <small>[CP] Ground Spur Gears</small>  Material: S45C CP5-20 Page 286	SRGCP/SRGCPF/SRGCPFD <small>[CP] Hardened Ground Racks</small>  Material: S45C CP5-20 Page 288	KRCPF-H/KRCPFD-H <small>[CP] Hardened Racks</small>  Material: SCM440 CP5, 10 Page 290	KSSCP-H <small>[CP] Hardened Thermal Refined Spur Gears</small>  Material: SCM440 CP5, 10 Page 292	KSSCP <small>[CP] Thermal Refined Spur Gears</small>  Material: SCM440 CP5, 10 Page 292	KRCPF/KRCPFD <small>[CP] Thermal Refined Racks</small>  Material: SCM440 CP5, 10 Page 292	SSCP-H <small>[CP] Hardened Spur Gears</small>  Material: S45C CP2.5-20 Page 294	SSCP <small>[CP] Spur Gears</small>  Material: S45C CP2.5-20 Page 294
SRCPF-H/SRCPFD-H <small>[CP] Hardened Racks</small>  Material: S45C CP5-20 Page 296	SRCPF-HL/SRCPFD-HL <small>[CP] Laser hardened</small>  Material: S45C CP5-20 Page 298	SRCP/SRCPF/SRCPFD/SRCPFK <small>[CP] Racks</small>  Material: S45C CP2.5-20 Page 300	SUSCP <small>[CP] Stainless Steel Spur Gears</small>  Material: SUS303 CP5, 10 Page 302	SURCPF/SURCPFD <small>[CP] Stainless Steel Racks</small>  Material: SUS304 CP5, 10 Page 302	SROCP <small>[CP] Round Racks</small>  Material: S45C CP2.5-10 Page 304	FRCP <small>[CP] Metal Flexible Racks</small>  Material: SS400 CP5 Page 304	

M Includes Made to Order



Catalog Number of KHK Stock Gears

The Catalog Number for KHK stock gears is based on the simple formula listed below. Please order KHK gears by specifying the Catalog Numbers.

(Example) CP Racks

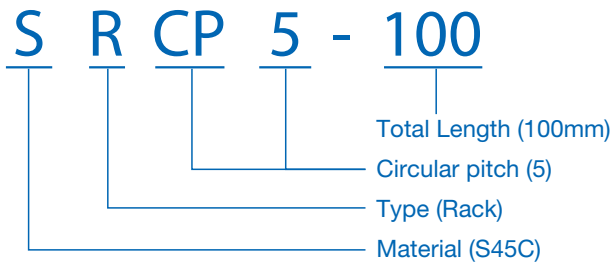

Material

M	SCM415
K	SCM440
S	S45C
SU	Stainless Steel
F	SS400

Type

R	Racks
RO	Round Racks
S	Spur Gears
TR(TS)	Tapered Racks (Spur Gears)

Other Information

F	Racks with Machined Ends
D	Racks with Bolt Holes
K	Racks with Drill Holes
G	Ground Gears
H	Gear teeth induction hardened
S	Pinion Shafts
HL	Laser hardened

Spur Gears
Helical Gears
Internal Gears
Racks
CP Racks & Pinions
Miter Gears
Bevel Gears
Screw Gears
Worm Gears
Gearboxes
Other Products

Features



The KHK stock CP racks & pinions are easy-to-use racks with clear pitch.

For your convenience, we offer circular pitches of 2.5 to 20 mm and in lengths of up to 2000 mm. (FRCP is available to 4000 mm)

Racks

Catalog Number <small>Note 1</small>	Pitch mm	Total Length mm Parentheses show no. of teeth	Material	Heat Treatment	Tooth Surface Finish	Gear accuracy <small>KHK R 001 Parentheses show JIS B 1702-1</small>	Features
STRCPF STRCPFD	5, 10	1000	S45C	—	Cut	4	Racks with tapered helix with adjustable backlash.
MRGCPF MRGCPFD	5, 10	500	SCM415	Carburized	Ground	1	CP racks that have been carburized and ground that have excellent accuracy, strength and wear resistance. Secondary operations are possible except for teeth and both ends.
KRGCPF-H KRGCPFD-H	5, 10	500, 1000	SCM440	Thermal refined, gear teeth induction hardened	Ground	1	CP racks that have been tempered, hardened and ground that have excellent accuracy, strength and wear resistance. Secondary operations are possible except for teeth.
KRGCP/KRGCPF KRGCPFD	5, 10	100, 500, 1000	SCM440	Thermal refined	Ground	1	CP racks that have been tempered and ground that have excellent accuracy and strength.
SRGCP/SRGCPF SRGCPFD	5, 10, 15, 20	100, 500, 1000	S45C	Gear teeth induction hardened	Ground	3	Racks that have been hardened and ground with a good balance of accuracy, wear resistance and cost. Secondary operations are possible except for teeth.
KRCPF-H KRCPFD-H	5, 10	1000	SCM440	Thermal refined, gear teeth induction hardened	Cut	5	CP racks that have been tempered and hardened that have excellent strength and wear resistance. Secondary operations are possible except for teeth.
SRCPF-H SRCPFD-H	5, 10, 15, 20	1000	S45C	Gear teeth induction hardened	Cut	5	CP racks that have been hardened with excellent wear resistance. Secondary operations are possible except for teeth.
SRCPF-HL SRCPFD-HL	5, 10, 15, 20	1000, 1500, 2000	S45C	Gear teeth laser hardened	Cut	4	CP racks that have been laser hardened with a good balance of wear resistance and cost. Secondary operations are possible except for teeth.
KRCPF/KRCPFD	5, 10	500, 1000	SCM440	Thermal refined	Cut	4	CP racks that have been tempered with excellent strength.
SRCP/SRCPF SRCPFD/SRCPFK	2.5, 5, 10, 15, 20	100, 500, 1000, 1500, 2000	S45C	—	Cut	4	Many lineups are available at a low price and excellent usability.
SURCPF SURCPFD	5, 10	500, 1000	SUS304	Solution treated	Cut	5	Stainless steel CP racks with rust resistance.
SROCP	2.5, 5, 10	500, 1000	S45C	—	Cut	4	CP round racks that are suitable when the rack side moves.
FRCP	5	2000, 3000, 4000	SS400	—	Cut	8	Thin CP racks that can be bent.

Pinion

KTSCP	5, 10	(20~40)	SCM440	Thermal refined	Cut	(N8)	STRCPF pinion with adjustable backlash.
KSCPG	5, 10	(25~40)	SCM440	Thermal refined, gear teeth induction hardened	Ground	(N6)	CP gears that have been tempered, hardened and ground that has excellent accuracy, strength and abrasion resistance. Recommended for pinions of ground CP racks Secondary operations are possible except for teeth.
SSCPGS	5, 10	(10~20)	S45C	Thermal refined, gear teeth induction hardened	Ground	(N7)	CP gears with shafts that have been tempered, hardened and ground. Secondary operations can be given except for the teeth. This product is ideal for the pinion of the SRGCPF rack.
SSCPG	5, 10, 15, 20	(20~40)	S45C	Gear teeth induction hardened	Ground	(N7)	CP gears that have been hardened and ground. Secondary operations can be given except for the teeth. This product is ideal for the pinion of the SRGCPF rack.
KSSCP	5, 10	(25~40)	SCM440	Thermal refined	Cut	(N8)	Tempered gears with excellent bending strength that can be given secondary operations. The teeth can be additionally hardened. This product is ideal for the pinion of the KRCPF rack.
SSCP	2.5, 5, 10, 15, 20	(20~40)	S45C	—	Cut	(N8)	Available at a low price. The teeth can be additionally hardened. This product is ideal for the pinion of the SRCP and SROCP racks.
SUSCP	5, 10	(20~30)	SUS303	—	Cut	(N8)	Stainless steel CP gears with rust resistance. This product is ideal for the pinion of the SURCPF rack.

[NOTE 1] The catalog numbers of the above racks with (F) suffix have both ends machined so that they can be butted against each other. The items with (D) have mounting screw holes for immediate assembly.

- KHK stock CP racks have round semi-topping at the corners of the top land of the gear tooth.
- Black products are KHK stock CP gears that have an applied black oxide coating for rust resistance.

CP racks & pinions are ideal for linear positioning.

CP Racks & Pinions

The design can be made easier by setting the moving length of one rotation of a pinion to an integer (mm). Circular pitch racks solve these problems. This problem is solved by CP racks and pinions where one rotation of a pinion moves it precisely 50, 100, 150, ... 600 mm, etc. The following table lists the main features.

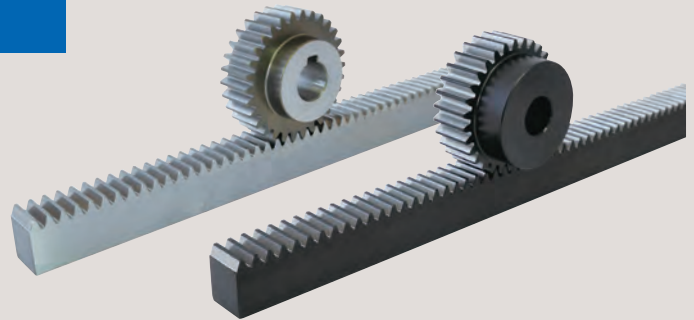

■ Movement of one cycle of the CP10-30 pinion vs SS3-30.

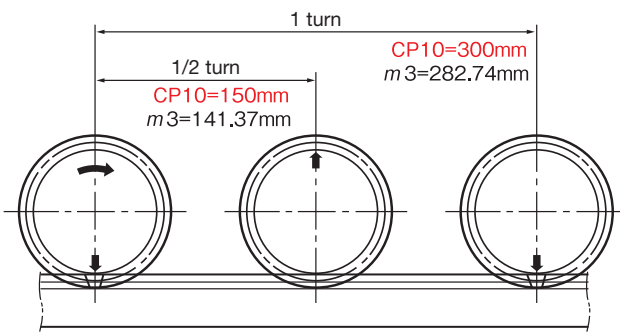

■ Difference between CP10 and m3

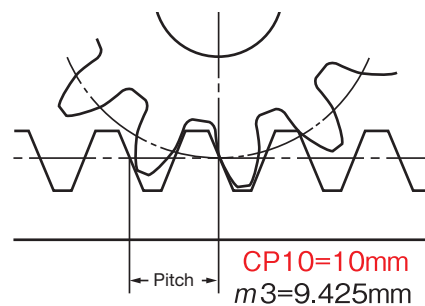

STRCPF/STRCPFD & KTSCP

Taper Racks & Pinions



■ Features of Tapered Racks & Pinions

- Easy to adjust the backlash
Normally, the backlash is adjusted by the mounting distance (height of pinion shaft), but for KHK Tapered Racks & Pinions, it can simply be adjusted by moving the pinion mounting position in the axial direction.
- Backlash within 0.05 mm
The backlash of the conventional stock racks & pinions (SRCP5-1000 & SSCP 5-30) is 0.09 to 0.25 mm, but KHK Tapered Racks & Pinions (STRCPF5-1000 & KTSCP5-30) are manufactured within 0.05 mm.
- Thrust load is not applied
As with ordinary racks & pinions, KHK Tapered Racks and Pinions can be used without worrying about the thrust load. Pinions are CP spur gears that are continuously shifted in the helix direction.

* For product details, please see Page 278.

■ Assembly and backlash adjustment method

- Assemble at the mounting distance of the theoretical value at the reference tooth position of the racks & pinions. For the mounting distance and backlash, see the dimension table of the tapered spur gear.
- The backlash can be adjusted by moving the tapered spur gear in the axial direction. Moving it by 1 mm will adjust the backlash by 0.05 mm.
- When the tapered spur gear is pushed to the large end of the rack, the backlash is reduced. Conversely, retracting it will increase the backlash.

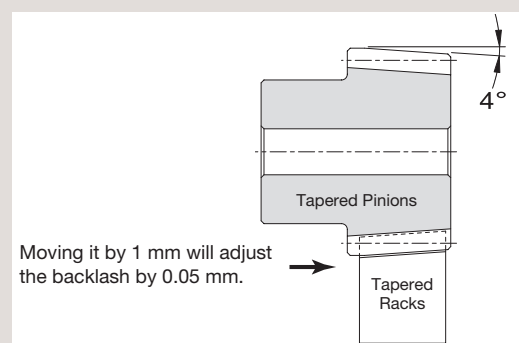

Application Examples

KHK stock CP racks & pinions are adopted in driving devices for linear systems, such as transport devices.

■ Rack Rail Assembly

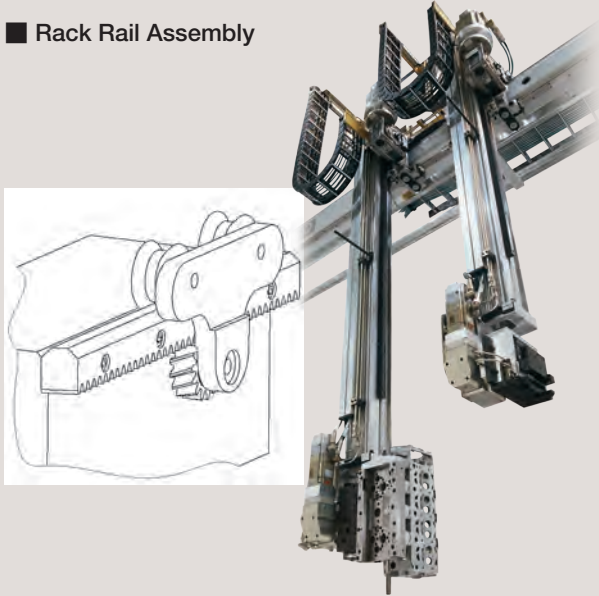

■ Rack Drive Linear Guide

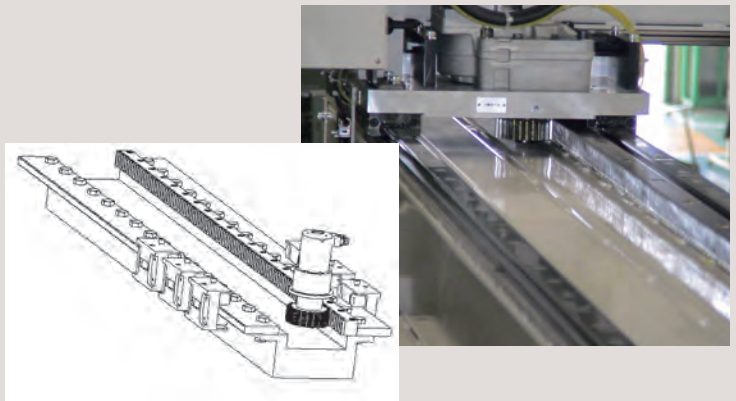

■ Cleaning machine manufactured by Kan Manufacturing Co., Ltd.

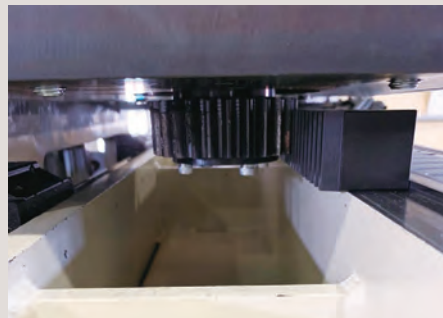
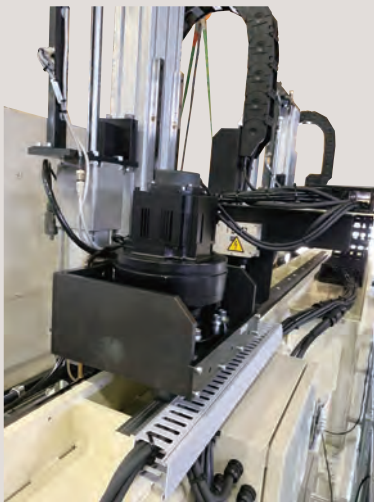

SRCPF-H racks and SSCP spur gears used in cleaning device with automatic transport for automobile parts

■ Examples of using tapered spur gears

Changing the assembly direction of the tapered spur gear or assembling it with a general spur gear will allow it to be used at the axial angle shown below.

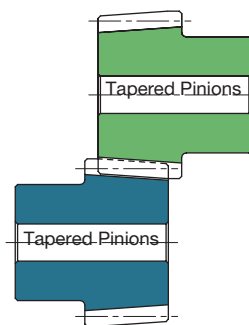

When the boss is set in the opposite direction, the axial angle is 0° (parallel shaft).

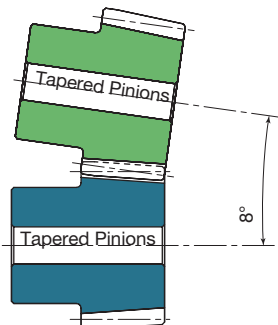

When the boss is set in the same direction, the axial angle is 8°.

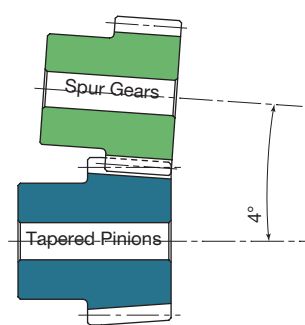

When the taper spur gear and general spur gear are set, the axial angle is 4°.

Selection Hints



Please select the most suitable products by carefully considering the characteristics of items and contents of the product tables. It is also important to read all applicable notes shown below before the final selection.

1. Caution in Selecting the Mating Gears

- ① KHK stock CP racks are mated with CP spur gears having the same pitch. Since CP2.5 (m0.796), CP5 (m1.592) and CP10 (m3.183) are very close in size to m0.8, m1.5 and m3 respectively, selecting the proper mating gear should be verified to make sure that the items are correct. Otherwise, complications could arise.
- ② STRCPF and STRCPFD Tapered CP Racks are mated with KTSCP Tapered CP Spur Gears having the same pitch.

2. Caution in Selecting Gears Based on Gear Strength

The gear strength values shown in the product pages were computed by assuming the application environment in the table below. Therefore, they should be used as reference only. We recommend that each user computes their own values by applying the actual usage conditions. The table below contains the assumptions established for various products in order to compute gear strengths.

■ Calculation of Bending Strength of Gears

Item	Racks							Pinion						
	MRGCPF MRGCPFD	KRGCPF-H KRGCPFD-H KRCPF-H KRCPPFD-H	KRGCP KRGCPF KRGCPFD KRCPF KRCPPFD	SRGCP SRGCPF SRGCPFD SRCPPFD-H	SRCPPFD-HL SRCPPFD-HL	SRCP/SRCPPFD SRCPFD SRCPFK SROCP STRCPF STRCPFD	SURCPF SURCPFD	FRCP	MSCPG	KSCPG KSSCP-H	SSCPGS	SSCPG SSCP-H	KTSCP KSSCP	SSCP
Formula <small>NOTE 1</small>	Formula of spur and helical gears on bending strength (JGMA401-01)													
No. of teeth of mating gears	30							Racks						
Rotational Speed of Pinion	100rpm													
Design Life (Durability)	Over 10 ⁷ cycles													
Impact from motor	Uniform load													
Impact from load	Uniform load													
Direction of load	Bidirectional load (calculated with allowable bending stress of 2/3)													
Allowable bending stress at root σ_{Fim} (kgf/mm ²)	47	30	29.5	20	20	20	10.5	47	30	24.5	19	29.5	19	10.5
Safety factor S_F	1.2													

■ Calculation of Surface Durability (Except where it is common with bending strength)

Formula <small>NOTE 1</small>	Formula of spur and helical gears on surface durability (JGMA402-01)														
Kinematic viscosity of lubricant	100cSt (50°C)														
How to support pinions	Supported on one end.														
Allowable Hertz stress σ_{Hlim} (kgf/mm ²)	166	112	76	90	80	52.5	41.3	-	166	112	99	90	76	49	41.3
Safety factor S_H	1.15														

[NOTE 1] The gear strength formula is based on JGMA (Japanese Gear Manufacturers Association) specifications.
The units for the rotational speed (rpm) and the stress (kgf/mm²) are adjusted to the units needed in the formula.

3. Cautions on Selecting Racks By Precision

The precision standards of KHK stock racks are established by us.
The table below indicates the tolerance ranges of our racks.

- ① Pitch Error of Racks (KHK R 001) → Page 219
- ② Precision of Rack Blanks → Page 220
- ③ Backlash of Rack Teeth → Page 220

When selecting KHK standard gears, glance over the Product Precautions on page 274 and Cautions on Performing Secondary Operations on each page.

- ① Products not listed in this catalog or materials, modules, number of teeth and the like not listed in the dimensional tables can be manufactured as custom items. Please see Page 26 for more details about custom-made orders.
- ② The color and shape of the product images listed on the dimension table page of each product may differ from the actual product. Be sure to confirm the shape in the dimension table before selection.
- ③ The details (specifications, dimensions, etc.) listed in the catalog may be changed without prior notice. Changes are announced on the KHK website.

Website URL: <https://khkgears.net/new/>
Overseas Sales Department: Phone: +81-48-254-1744 Fax: +81-48-254-1765 E-mail: info@khkgears.net

Product Precautions



CP Rack Common Notes

[Caution on Product Characteristics]

- (1) The allowable forces shown in the table are calculated values according to the assumed usage conditions. Please see page 273 for more details.
- (2) The backlash values shown in the table are the theoretical values for the backlash in the circumferential direction of recommended pinions with the same pitch.
- (3) After attaching the racks to the base, fasten with dowel pins. Clamping only with mounting screws could possibly cause the screws to be broken, due to a heavy load.
- (4) See page 22 for more details on Hardened Plus (H Series and HJ Series).
 - KHK's Specifications for Heat Treatment
 - Hardened location: Tooth surface, or Tooth surface and Tooth root
 - Hardness: 50 to 60 HRC
 - * Hardness and Depth of Gear-teeth Induction Hardening
 - The hardening method and the state of the hardened teeth area vary depending on the size of gears.
 - Since different hardening treatment is applied in accordance with the module and number of teeth, the hardness level is referred to as the hardness of the reference diameter.
 - For some of our products, the hardness at tooth tip / root may not be equal to the hardness you designated.
 - As to the effective case depth, it is specified by JIS, as "The distance from the surface of the case to the area with hardness HV450." The case depth differs from area to area of a tooth, so the depth cannot be specified.
 - Due to the gear teeth of racks and gears being induction hardened, no secondary operations can be performed on tooth areas including the bottom land (approx. 2 to 3 mm) and tooth areas at the end face of the rack (approx. 4 to 5 mm).
- (5) There is a decarburized layer on the surface, so 0.5mm or so will not be at the specified hardness.

[J Series]

- (1) Number of pieces we can process for one order is 1 to 20 units. For larger orders, please request a price and delivery quote.
- (2) Black oxide is not re-applied to parts undergoing secondary operations.

CP Spur Gears Common Notes

[Caution on Product Characteristics]

- (1) The allowable torque shown in the table are calculated values according to the assumed usage conditions. Please see page 273 for more details.
- (2) The backlash values shown in the table are the theoretical values for the backlash in the circumferential direction of recommended mating racks with the same pitch.
- (3) Keyways are made according to JIS B1301 standards, Js9 tolerance. Also note that keyway tooth position alignment is not performed.
- (4) For products having a tapped hole, a set screw is included.
- (5) For hole lengths 3.5x the bore or more, the hole center is out of H7 tolerance.
- (6) See page 22 for more details on Hardened Plus (H Series and HJ Series).
 - KHK's Specifications for Heat Treatment
 - Hardened location: Tooth surface, or Tooth surface and Tooth root
 - Hardness: 50 to 60 HRC
 - * Hardness and Depth of Gear-teeth Induction Hardening
 - The hardening method and the state of the hardened teeth area vary depending on the size of gears.
 - Since different hardening treatment is applied in accordance with the module and number of teeth, the hardness level is referred to as the hardness of the reference diameter.
 - For some of our products, the hardness at tooth tip / root may not be equal to the hardness you designated.
 - As to the effective case depth, it is specified by JIS, as "The distance from the surface of the case to the area with hardness HV450." The case depth differs from area to area of a tooth, so the depth cannot be specified.
 - Due to the gear teeth being induction hardened, no secondary operations can be performed on tooth areas including the bottom land (approx. 2 to 3 mm).

[J Series]

- (1) For bores over $\phi 50$, the bore tolerance is H8.
- (2) Certain products which would otherwise have a very long tapped hole are counterbored. For details, please see the KHK website.
- (3) Black oxide is not re-applied to parts undergoing secondary operations.

MEMO

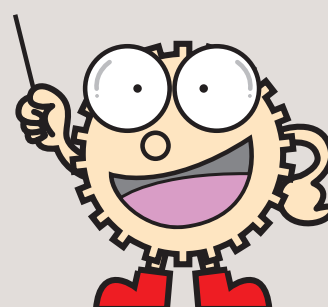

Application Hints



In order to use KHK stock CP racks safely, carefully read the Application Hints before proceeding. If there are questions or you require clarifications, please contact our technical department or your nearest distributor. E-mail: info@khkgears.net
Please read "Cautions on Performing Secondary Operations" below when performing modifications and/or secondary operations for safety concerns.

1. Cautions on Handling

- ① KHK products are packaged one by one to prevent scratches and dents, but if you find issues such as rust, scratches, or dents when the product is removed from the box after purchase, please contact the supplier.
- ② Depending on the handling method, the product may become deformed or damaged. Long racks and round racks deform particularly easily, so please handle with care.

2. Caution on Performing Secondary Operations

- ① Secondary operations can be performed on all KHK stock CP racks except for the racks with their gear teeth induction hardened. To avoid problems of gear precision, do not reduce the face width.
- ② Height of pitch lines of racks are controlled by the bottom surface as the reference datum and over-pin measurements on tooth thickness. If you machine the bottom surfaces, the precision of the racks may be affected.
- ③ When connecting two racks, the machining of the mating end pitch (CP) requires careful consideration. The meshing will be poor if the pitch straddling the connection has a positive tolerance. We recommend a minus tolerance on pitch of at the connection. The below is an indication of pitch tolerance for each module.

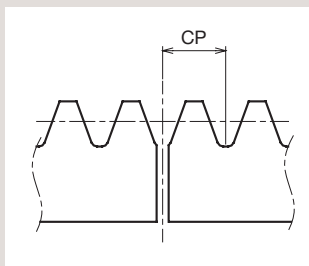

Unit: mm

CP	Tolerance
CP2.5	-0.05 -0.25
CP5	-0.1 -0.3
CP10	
CP15	-0.1 -0.4
CP20	

- ④ To use dowel pins to secure racks, attach the racks to the base and drill both simultaneously.
- ⑤ KHK stock CP racks made of S45C and SCM440 (except for ground racks) can be induction hardened. However, the precision of pitch is decreased.
- ⑥ To be able to handle parts safely, all burrs and sharp corners should be removed after the secondary operations are done.
- ⑦ If you are going to modify the gear by gripping the teeth, please exercise caution not to crush the teeth by applying too much pressure. Any scarring will cause noise during operation.
- ⑧ There is a decarburized layer (about 0.5 mm) on the surface of the extruded products. The hardness of the decarburized layer does not increase even if it is quenched.

3. Points of Caution during Assembly

- ① The recommended assembly distance tolerance of KHK stock CP racks is H7 for ground racks and H8 for cut racks.
The backlash values are given in the table on Page 220. Make sure that the mounting distance stays constant for the length of the rack.

Mounting distance a = Height of pitch line of rack + Pitch radius of pinion

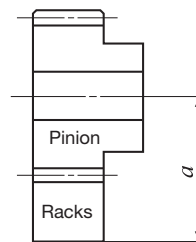

[NOTE] Pinions are assumed to be standard stock spur gears ($x=0$).

- ② The recommended flatness and squareness of the mounting surface of KHK stock CP racks is 0.01 mm for ground racks and 0.05 mm for cut racks.

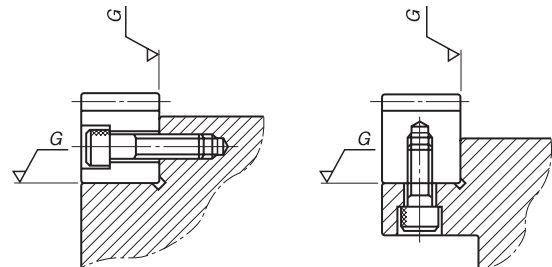

- ③ If the racks are not secured properly to the base, they could shift during operation and cause unexpected problems.
It is very important to insure firm mounting by the use of dowel pins or similar devices.
- ④ Machined end type racks such as SRCPF and SRCPFD series have smaller pitch tolerance at the end face. If you try to connect the racks without any space, the pitch at the connection will be too small and will cause problems. Please follow the following diagrams for assembly.
- ⑤ With SRCPFD etc., if using more than 10 racks connected together to form a rack with mounting holes machined along a length of 1 meter, the pitch precision and machining precision may cause the rack and base mounting holes to deviate, leading to set screw interference with the counterbored hole and preventing mounting. When using a rack for long lengths such as 10 meters or 20 meters, have the mounting holes additionally machined into long holes.

As an example of Rack Joining, we recommend the following method.

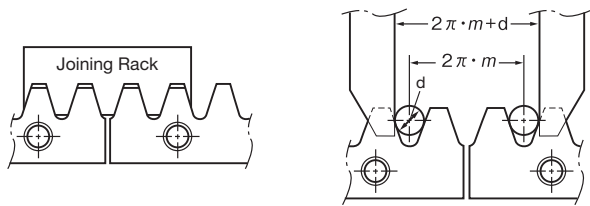

[NOTE] Joining gauge racks for helical racks must have the opposite hand from the racks. Please use 100 mm short racks as a joining gauge rack, or alternatively the rack of the same specifications on hand.

How to mount racks on a mounting base (For SRFD2-1000)

1. Pitch alignment

Place SRFD2-1000 on the mounting base, align SR2-100 and temporarily tighten the bolt.

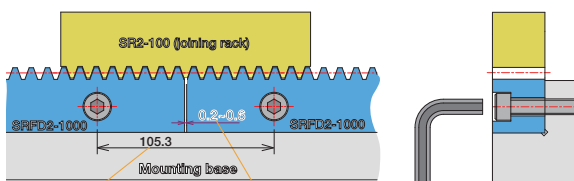

Dimensions Table F Value x 2 SRFD2-1000 is designed to have a gap of 0.2 to 0.6 mm.

2. Securing to the mounting base

Tap with a plastic hammer, bring it into close contact with the mounting base, and further tighten the bolt.

(When using a metal hammer, be careful not to damage the gear teeth by using a stiffening plate, etc.)

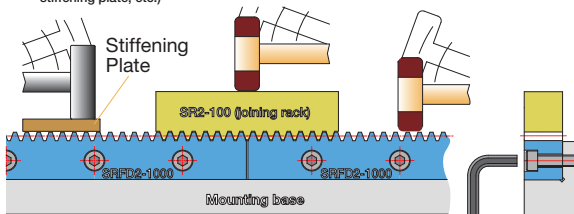

3. Run the pinion and check the following

- ① Is there abnormal noise or vibration?
- ② Is the backlash appropriate?
- ③ Is there poor edge contact of gear teeth?

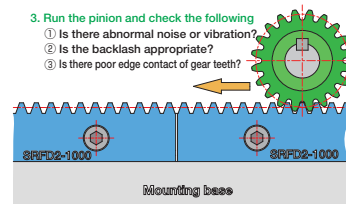

4. Secure fixation to the mounting base

We recommend that you tap the knock pin so that the rack does not shift due to vibration, etc.

- ① Simultaneously machine reamer holes

Reamer hole

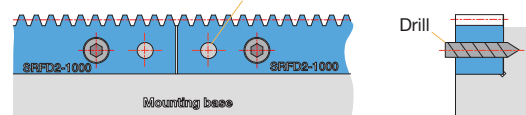

- ② Drive the knock pin

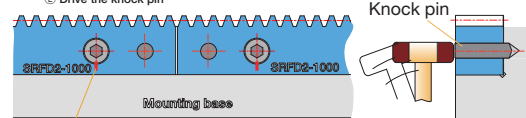

Tighten again after tapping the knock pin. It can be marked with a pen to find looseness.

4. Cautions on Starting

- ① Check the following items before starting.
 - Are the gears installed securely?
 - Is there uneven tooth contact?
 - Is there adequate backlash?
(Be sure to avoid zero-backlash.)
 - Has proper lubrication been supplied?
- ② If gears are exposed, be sure to attach a safety cover to ensure safety. Also, be careful not to touch rotating gears.
- ③ If there is any abnormality such as noise or vibration during startup, stop the operation immediately and check the assembly condition such as tooth contact, eccentricity and looseness.

KHK considers safety a priority in the use of our products.

When handling, adding secondary operations, assembling, and operating KHK products, please be aware of the following issues in order to prevent accidents.



Warning: Precautions for preventing physical and property damage

1. When using KHK products, follow relevant safety regulations (Occupational Safety and Health Regulations, etc.).
2. Pay attention to the following items when installing, removing, or performing maintenance and inspection of the product.
 - ① Turn off the power switch.
 - ② Do not reach or crawl under the product.
 - ③ Wear appropriate clothing and protective equipment for the work.



Caution: Cautions in Preventing Accidents

1. Before using a KHK product, read the precautions in the catalog carefully in order to use it correctly.
2. Avoid use in environments that may adversely affect the product.
3. Our products are manufactured under a superior quality control system based on the ISO9001 quality management system; if you notice any malfunctions upon purchasing a product, please contact the supplier.



CP Tapered Pinions



Specifications	
Precision grade	JIS grade N8 (JIS B1702-1: 1998)
Gear teeth	Standard full depth
Pressure angle	20°
Material	SCM440
Heat treatment	Thermal refining only
Tooth hardness	225 to 352HB
Surface treatment	Black oxide coating

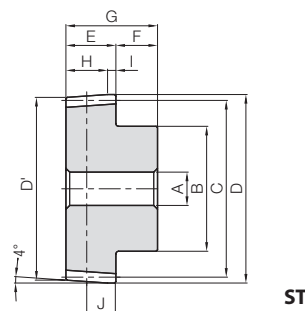

ST

Catalog Number	Pitch mm (Module)	No. of teeth	Shape	Bore		Pitch dia. C	Outside dia. (major) D	Outside dia. (minor) D'	Total tooth width E	Hub width F	Total length G
				AH7	B						
KTSCP5-20	CP5 (1.5915)	20	ST	8	25	31.83	36.06	33.97	18	15	33
KTSCP5-30		30		10	38	47.75	51.98	49.88			
KTSCP5-40		40		12	45	63.66	67.89	65.8			
KTSCP10-20	CP10 (3.1831)	20		15	50	63.66	72.13	67.93	36	20	56
KTSCP10-25		25		20	60	79.58	88.04	83.85			
KTSCP10-30		30		20	75	95.49	103.96	99.76			

Spur Gears

Helical Gears

Internal Gears

Racks

CP Racks & Pinions

Miter Gears

Bevel Gears

Screw Gears

Worm Gears

Gearboxes

Other Products



CP Tapered Racks



Specifications	
Precision grade	KHK R 001 grade 4
Gear teeth	Standard full depth
Pressure angle	20°
Material	S45C
Heat treatment	—
Tooth hardness	(less than 210HB)
Surface treatment	Black oxide coating

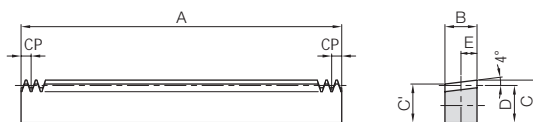

RF

Catalog Number	Pitch mm (Module)	No. of teeth	Shape	Total Length	Face width	Height (major)	Height (minor)	Height to pitch line	Position of reference tooth
				A	B	C	C'	D	E
STRCPF5-1000	CP5 (1.5915)	200	RF	1000	15	19.5	18.45	17.38	7.5
STRCPF10-1000	CP10 (3.1831)	100							

Catalog Number	Pitch mm (Module)	No. of teeth	Shape	Total Length	Face width	Height (major)	Height (minor)	Height to pitch line	Position of reference tooth	Mounting hole dimensions				
				A	B	C	C'	D	E	F	G	H	No. of holes	Screw size
STRCPFD5-1000	CP5 (1.5915)	200	RD	1000	15	19.5	18.45	17.38	7.5	8	50	180	6	M5
STRCPFD10-1000	CP10 (3.1831)	100												

[Caution on Product Characteristics] ① When connecting the racks to use as a continuous rack length, adjust the pitch of the joint using identical racks or with an SRCP□-100 rack product of the same pitch. Please read Points of Caution in Assembling (Page 276) for details.

[Caution on Secondary Operations] ① Avoid hardening racks with bolt holes, due to mounting hole deformation.

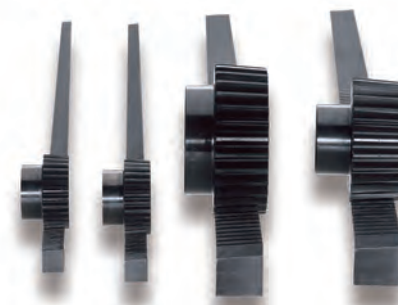
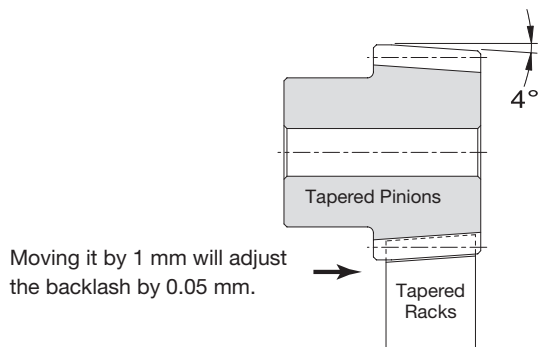

Reference face width H	Adjustable width I	Position of reference tooth J	Distance traveled in one turn (mm)	Allowable torque (N·m)		Allowable torque (kgf·m)		Mounting distance (mm)	Backlash (mm)	Weight (kg)	Catalog Number
				Bending strength	Surface durability	Bending strength	Surface durability				
15	3	10.5	100	42.7	7.89	4.35	0.80	33.30	0~0.11	0.16 0.37 0.61	KTSCP5-20 KTSCP5-30 KTSCP5-40
			150	72.8	21.0	7.42	2.15	41.26			
			200	104	41.7	10.6	4.25	49.21			
30	6	21	200	341	68.2	34.8	6.96	62.10	0~0.12	1.13 1.71 2.58	KTSCP10-20 KTSCP10-25 KTSCP10-30
			250	461	117	47.0	11.9	70.06			
			300	582	182	59.4	18.0	78.02			

Spur Gears
Helical Gears
Internal Gears
Racks
CP Racks & Pinions

Tapered Racks

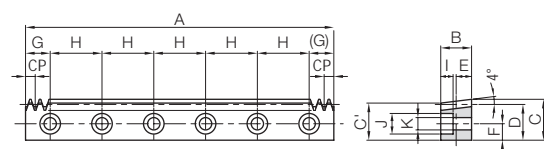

RD

SRCP5-100, SRCP10-100
Assembly Gauges
Material: S45C
Accuracy: KHK R 001 Grade 4
Please see Page 300 in the Master Catalog for more details.

Allowable force (N)		Allowable force (kgf)		Backlash (mm)	Weight (kg)	Catalog Number
Bending strength	Surface durability	Bending strength	Surface durability			
2290	421	233	42.9	0~0.11	2.05	STRCPF5-1000
9150	1820	933	186	0~0.12	7.13	STRCPF10-1000

Counterbore dimensions			Allowable force (N)		Allowable force (kgf)		Backlash (mm)	Weight (kg)	Catalog Number
I	J	K	Bending strength	Surface durability	Bending strength	Surface durability			
6	10	6	2290	421	233	42.9	0~0.11	2.01	STRCPFD5-1000 STRCPFD10-1000
10.8	17.5	11	9150	1820	933	186	0~0.12	6.92	

Miter Gears
Bevel Gears
Screw Gears
Worm Gears
Gearboxes
Other Products



Specifications	
Precision grade	JIS grade N5 (JIS B1702-1: 1998)
Gear teeth	Standard full depth
Pressure angle	20°
Material	SCM415
Heat treatment	Carburized
Tooth hardness	55 to 60HRC

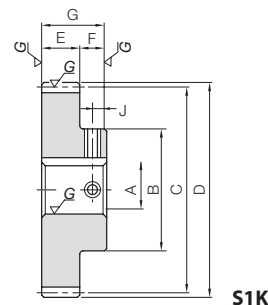

S1K

Catalog Number	Pitch mm (Module)	No. of teeth	Profile shift coefficient	Mounting distance	Shape	Bore	Hub dia.	Pitch dia.	Outside dia.	Face width	Hub width	Total length
						A _{H7}	B	C	D	E	F	G
MSCPG5-20A (Made to Order) MSCPG5-20B (Made to Order)	CP5 (1.5915)	20	+0.425	35	S1K	12	28	31.83	36.37	15	15	30
15												
MSCPG5-25A (Made to Order) MSCPG5-25B (Made to Order)		25	+0.438	39		12	35	39.79	44.37			
15												
MSCPG5-30A (Made to Order) MSCPG5-30B (Made to Order)		30	+0.451	43		15	40	47.75	52.37			
20												
MSCPG5-40A (Made to Order) MSCPG5-40B (Made to Order) MSCPG5-40C (Made to Order)	40	+0.478	51	15	45	63.66	68.37					
20												
MSCPG10-20A (Made to Order) MSCPG10-20B (Made to Order)	CP10 (3.1831)	20	+0.111	64	S1K	20	50	63.66	70.73	30	20	50
25												
MSCPG10-25A (Made to Order) MSCPG10-25B (Made to Order)		25	+0.124	72		25	60	79.58	86.73			
30												
MSCPG10-30A (Made to Order) MSCPG10-30B (Made to Order)		30	+0.137	80		30	70	95.49	102.73			
40												
MSCPG10-40A (Made to Order) MSCPG10-40B (Made to Order)	40	+0.164	96	30	70	127.32	134.73					
40												

[Caution on Product Characteristics] ① The keyway tolerance is the value before hardening.

[Precautions for Made to Order Products] ① Prices and lead times for Made to Order products require separate estimates. Contact your dealer.

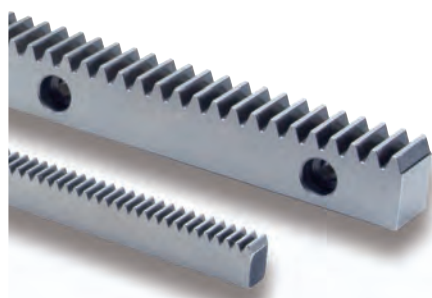

Specifications	
Precision grade	KHK R 001 Grade 1 *
Gear teeth	Standard full depth
Pressure angle	20°
Material	SCM415
Heat treatment	Carburized **
Tooth hardness	55 to 60HRC

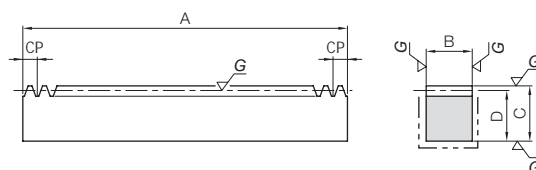

RF

* The precision grade of J Series products is equivalent to the value shown in the table.
** In the illustration, the area surrounded with - - - line is masked during the carburization process (max. HRC40 or so) and can be modified.

Catalog Number	Pitch mm (Module)	No. of teeth	Shape	Total Length	Face width	Height	Height to pitch line	Allowable force (N)		Allowable force (kgf)		Backlash (mm)	Weight (kg)
				A	B	C	D	Bending strength	Surface durability	Bending strength	Surface durability		
MRGCPF5-500	CP5 (1.5915)	100	RF	500	15	20	18.41	5380	5000	548	509	0.04~0.14	1.08
MRGCPF10-500	CP10 (3.1831)	50	RF	500	30	35	31.82	21500	20100	2190	2050	0.05~0.16	3.75

Catalog Number	Pitch mm (Module)	No. of teeth	Shape	Total Length	Face width	Height	Height to pitch line	Mounting hole dimensions				
				A	B	C	D	E	F	G	No. of holes	Screw size
● MRGCPFD5-500J	CP5 (1.5915)	100	RD	500	15	20	18.41	8	25	150	4	M5
● MRGCPFD10-500J	CP10 (3.1831)	50	RD	500	30	35	31.82	14	25	150	4	M10

[Caution on J series] ① Cancellation is not possible for made-to-order products. See page 42 for lead times and allowable order quantities. See page 44 for other precautions.



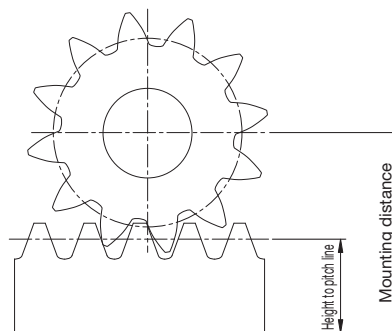
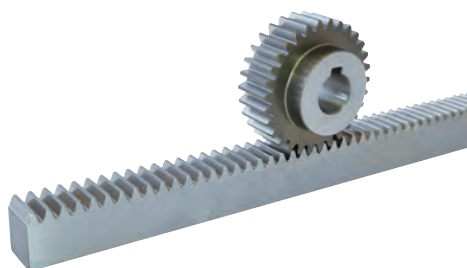

Mounting distance of a profile shifted gear and the meshing rack

Keyway Width x Depth	Socket head screw		Distance traveled in one turn (mm)	Allowable torque (N·m)		Allowable torque (kgf·m)		Backlash (mm)	Weight (kg)	Catalog Number
	Size	J		Bending strength	Surface durability	Bending strength	Surface durability			
4x 1.8 5x 2.3	M4	7.5	100	70.0	46.7	7.13	4.76	0.04~0.14	0.14 0.13	MSCPG5-20A (Made to Order) MSCPG5-20B (Made to Order)
4x 1.8 5x 2.3	M4		125	91.8	78.2	9.37	7.97		0.24 0.22	MSCPG5-25A (Made to Order) MSCPG5-25B (Made to Order)
5x 2.3 6x 2.8	M4 M5		150	114	119	11.6	12.2		0.32 0.29	MSCPG5-30A (Made to Order) MSCPG5-30B (Made to Order)
5x 2.3 6x 2.8 8x 3.3	M4 M5 M6		200	159	229	16.2	23.4		0.53 0.50 0.45	MSCPG5-40A (Made to Order) MSCPG5-40B (Made to Order) MSCPG5-40C (Made to Order)
6x 2.8 8x 3.3	M5 M6		200	514	375	52.4	38.2		0.94 0.87	MSCPG10-20A (Made to Order) MSCPG10-20B (Made to Order)
8x 3.3	M6	10	250	689	628	70.3	64.1	0.05~0.16	1.43 1.34	MSCPG10-25A (Made to Order) MSCPG10-25B (Made to Order)
8x 3.3 12x 3.3	M6 M8		300	868	960	88.5	97.9		2.03 1.80	MSCPG10-30A (Made to Order) MSCPG10-30B (Made to Order)
8x 3.3 12x 3.3	M6 M8		400	1230	1850	126	188		3.36 3.13	MSCPG10-40A (Made to Order) MSCPG10-40B (Made to Order)

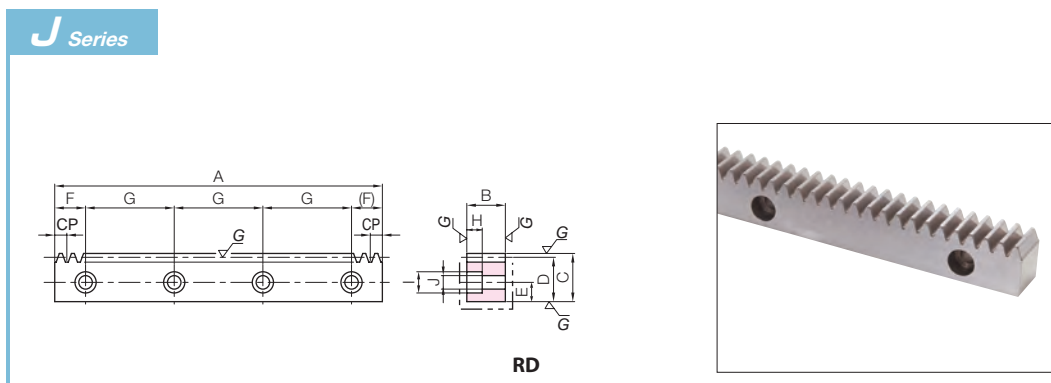

Surface durability is 4 times higher than SRGCP Hardened Ground Racks, 2 times higher than KRGCP-H Hardened Ground Racks.

Counterbore dimensions			Allowable force (N)		Allowable force (kgf)		Backlash (mm)	Weight (kg)	Catalog Number
H	I	J	Bending strength	Surface durability	Bending strength	Surface durability			
6	10	6	5380	5000	548	509	0.04~0.14	1.06	● J Series (Available-on-request) ●MRGCPFD5-500J
10.8	17.5	11	21500	20100	2190	2050	0.05~0.16	3.61	●MRGCPFD10-500J



Specifications	
Precision grade	JIS grade N6 (JIS B 1702-1: 1998) *
Gear teeth	Standard full depth
Pressure angle	20°
Material	SCM440
Heat treatment	Thermal refined, gear teeth induction hardened **
Tooth hardness	50 to 60HRC
Surface treatment	Black oxide coated except for teeth
Shape	S1

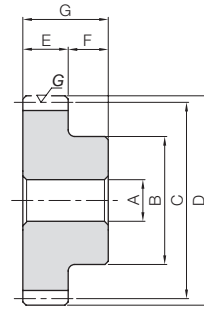

S1

* The precision grade of J Series products is equivalent to the value shown in the table.
 ** Due to the gear teeth being induction hardened, no secondary operations can be performed on tooth areas including the bottom land (approx. 2 to 3 mm).

Catalog Number	Pitch mm (Module)	No. of teeth	Profile shift coefficient	Mounting distance	Bore				Pitch dia.	Outside dia.	Face width	Hub width	Total length	Distance traveled in one turn (mm)	Allowable torque (N·m)		Allowable torque (kgf·m)		Backlash (mm)	Weight (kg)
					A _{H7}	B	C	D							Bending strength	Surface durability	Bending strength	Surface durability		
KSCPG5-25	CP5 (1.5915)	25	+0.438	39	10	35	39.79	44.37	15	15	30			125	58.6	35.6	5.98	3.63	0.04~0.14	0.25
KSCPG5-30		30	+0.451	43	15	40	47.75	52.37						150	72.8	54.3	7.42	5.54		
KSCPG5-40		40	+0.478	51	15	55	63.66	68.37						200	101	104	10.3	10.6		
KSCPG10-25	CP10 (3.1831)	25	+0.124	72	20	70	79.58	86.73	30	20	50			250	440	286	44.9	29.2	0.05~0.16	1.68
KSCPG10-30		30	+0.137	80	20	85	95.49	102.73						300	554	437	56.5	44.5		
KSCPG10-40		40	+0.164	96	25	110	127.32	134.73						400	786	841	80.1	85.8		

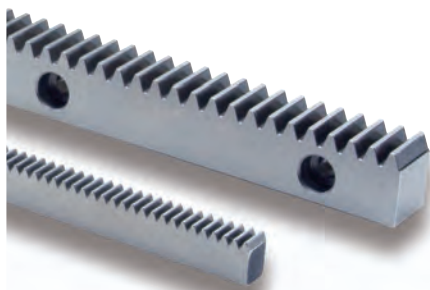

Specifications	
Precision grade	KHK R 001 Grade 1 *
Gear teeth	Standard full depth
Pressure angle	20°
Material	SCM440
Heat treatment	Thermal refined, gear teeth induction hardened **
Tooth hardness	50 to 60HRC

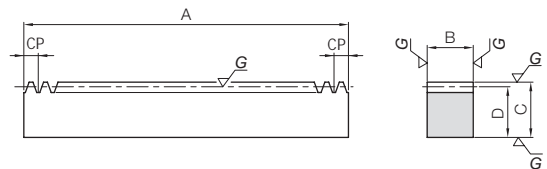

RF

* The precision grade of J Series products is equivalent to the value shown in the table.
 ** Due to the gear teeth being induction hardened, no secondary operations can be performed on tooth areas including the bottom land (approx. 2 to 3 mm).

Catalog Number	Pitch mm (Module)	No. of teeth	Shape	Total Length				Allowable force (N)		Allowable force (kgf)		Backlash (mm)	Weight (kg)
				A	B	C	D	Bending strength	Surface durability	Bending strength	Surface durability		
KRGCPF5-500H	CP5 (1.5915)	100	RF	500	15	20	18.41	3170	2270	323	232	0.04~0.14	1.08
KRGCPF5-1000H		200		1000									
KRGCPF10-500H	CP10 (3.1831)	50	RF	500	30	35	31.82	13400	9150	1370	933	0.05~0.16	3.75
KRGCPF10-1000H		100		1000									

Catalog Number	Pitch mm (Module)	No. of teeth	Shape	Total Length				Mounting hole dimensions				
				A	B	C	D	E	F	G	No. of holes	Screw size
● KRGCPFD5-500HJ	CP5 (1.5915)	100	RD	500	15	20	18.41	8	25	150	4	M5
● KRGCPFD5-1000HJ		200		1000								
● KRGCPFD10-500HJ	CP10 (3.1831)	50	RD	500	30	35	31.82	14	25	150	4	M10
● KRGCPFD10-1000HJ		100		1000								

[Caution on J series] ① Cancellation is not possible for made-to-order products. See page 42 for lead times and allowable order quantities. See page 44 for other precautions.



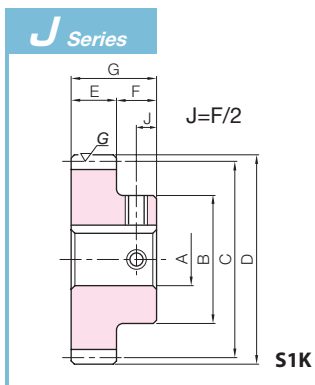

To order J Series products, please specify: **Catalog No. + J + BORE.**

Bore H7	* The product shapes of J Series items are identified by background color.																		
	10	12	14	15	16	17	18	19	20	22	25	28	30	32	35	40	45	50	
Keyway JS9	4x1.8			5x2.3				6x2.8				8x3.3			10x3.3		12x3.3	14x3.8	
Screw size	M4				M5				M6			M8			M10				
Catalog Number																			
KSCPG5-25 J BORE																			
KSCPG5-30 J BORE																			
KSCPG5-40 J BORE																			
KSCPG10-25 J BORE																			
KSCPG10-30 J BORE																			
KSCPG10-40 J BORE																			

[Caution on J series] ① Cancellation is not possible for made-to-order products. See page 42 for lead times and allowable order quantities. See page 44 for other precautions.

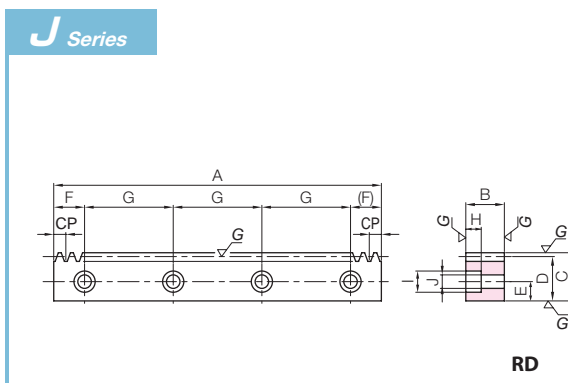

CP Ground Racks



Counterbore dimensions			Allowable force (N)		Allowable force (kgf)		Backlash (mm)	Weight (kg)	Catalog Number ● : J Series (Available-on-request)
H	I	J	Bending strength	Surface durability	Bending strength	Surface durability			
6	10	6	3170	2270	323	232	0.04~0.14	1.06 2.13	● KRGCPFD5-500HJ ● KRGCPFD5-1000HJ
10.8	17.5	11	13400	9150	1370	933	0.05~0.16	3.61 7.28	● KRGCPFD10-500HJ ● KRGCPFD10-1000HJ

CP Thermal Refined Ground Racks

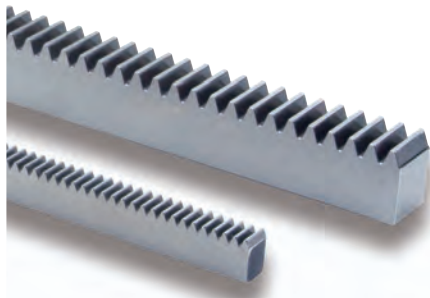

Specifications	
Precision grade	KHK R 001 grade 1 *
Gear teeth	Standard full depth
Pressure angle	20°
Material	SCM440
Heat treatment	Thermal refining only
Tooth hardness	225 to 352HB

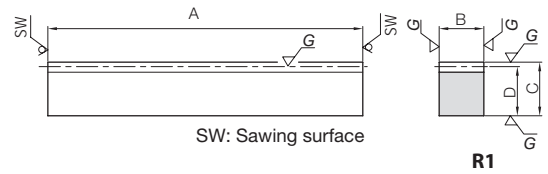

* The precision grade of J Series products is equivalent to the value shown in the table.

Catalog Number	Pitch mm (Module)	Effective number of teeth	Shape	Total Length	Face width	Height	Height to pitch line	Allowable force (N)		Allowable force (kgf)	
				A	B	C	D	Bending strength	Surface durability	Bending strength	Surface durability
KRGCP5-100	CP5 (1.5915)	18	R1	98	15	20	18.41	3120	1430	318	145
KRGCP10-100	CP10 (3.1831)	8		98	30	35	31.82	13200	5740	1350	585

Catalog Number	Pitch mm (Module)	No. of teeth	Shape	Total Length	Face width	Height	Height to pitch line	Allowable force (N)		Allowable force (kgf)	
				A	B	C	D	Bending strength	Surface durability	Bending strength	Surface durability
KRGCPF5-500	CP5 (1.5915)	100	RF	500	15	20	18.41	3120	1430	318	145
KRGCPF5-1000		200		1000							
KRGCPF10-500	CP10 (3.1831)	50		500	30	35	31.82	13200	5740	1350	585
KRGCPF10-1000		100		1000							

Catalog Number	Pitch mm (Module)	No. of teeth	Shape	Total Length	Face width	Height	Height to pitch line	Mounting hole dimensions				
				A	B	C	D	E	F	G	No. of holes	Screw size
● KRGCPFD5-500J	CP5 (1.5915)	100	RD	500	15	20	18.41	8	25.00	150	4	M5
● KRGCPFD5-1000J		200		1000								
● KRGCPFD10-500J	CP10 (3.1831)	50		500	30	35	31.82	14	25.00	150	4	M10
● KRGCPFD10-1000J		100		1000								

[Caution on J series] ① Cancellation is not possible for made-to-order products. See page 42 for lead times and allowable order quantities. See page 44 for other precautions.

- Spur Gears
- Helical Gears
- Internal Gears
- Racks
- CP Racks & Pinions
- Miter Gears
- Bevel Gears
- Screw Gears
- Worm Gears
- Gearboxes
- Other Products

J Series

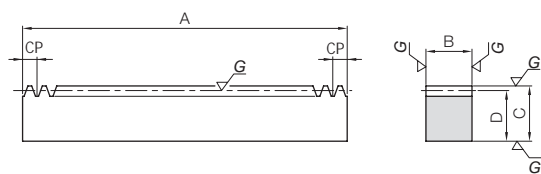

RF

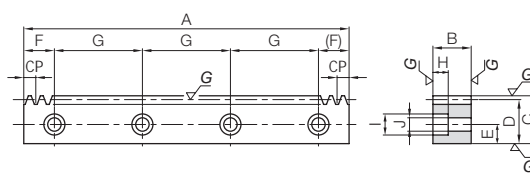

RD

Backlash (mm)	Weight (kg)	Catalog Number
0.04~0.14	0.21	KRGCP5-100
0.05~0.16	0.73	KRGCP10-100

Backlash (mm)	Weight (kg)	Catalog Number
0.04~0.14	1.08 2.17	KRGCPF5-500 KRGCPF5-1000
0.05~0.16	3.75 7.49	KRGCPF10-500 KRGCPF10-1000

Counterbore dimensions			Allowable force (N)		Allowable force (kgf)		Backlash (mm)	Weight (kg)	Catalog Number
H	I	J	Bending strength	Surface durability	Bending strength	Surface durability			
6	10	6	3120	1430	318	145	0.04~0.14	1.06 2.13	● J Series (Available-on-request) ● KRGCPFD5-500J ● KRGCPFD5-1000J
10.8	17.5	11	13200	5740	1350	585	0.05~0.16	3.61 7.28	● KRGCPFD10-500J ● KRGCPFD10-1000J

Spur Gears

Helical Gears

Internal Gears

Racks

CP Racks & Pinions

Miter Gears

Bevel Gears

Screw Gears

Worm Gears

Gearboxes

Other Products

Recommended Mating Pinions



SSCPG

Please see Page 286 for more details.

Rack & Pinion Lubrication System

PUS lubricated spur gear

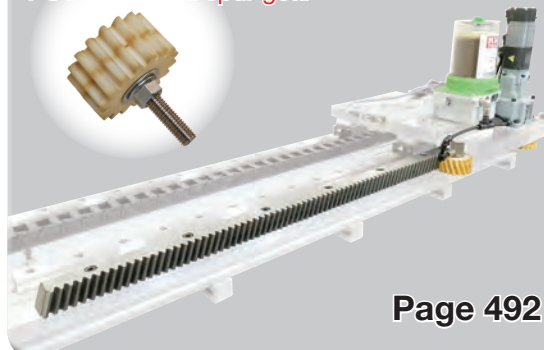

Page 492



SSCPGS Circular pitch 5, 10

CP Ground Spur Pinion Shafts



Specifications	
Precision grade	JIS grade N7 (JIS B1702-1: 1998)
Gear teeth	Standard full depth
Pressure angle	20°
Material	S45C
Heat treatment	Thermal refined, gear teeth induction hardened *
Tooth hardness	50 to 60HRC
Surface treatment	Black oxide coated except for ground part

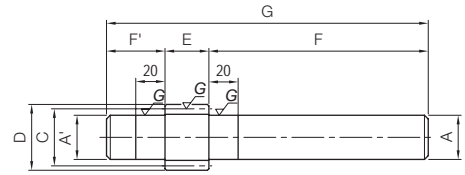

S7

* Due to the gear teeth being induction hardened, no secondary operations can be performed on tooth areas including the bottom land (approx. 2 to 3 mm).

Catalog Number	Pitch mm (Module)	No. of teeth	Profile shift coefficient	Shape	Shaft diameter (L)		Pitch dia.	Outside dia.	Face width	Shaft diameter (R)	
					A'	F'				A	F
SSCPGS5-15 SSCPGS5-20	CP5 (1.5915)	15	0	S7	19.2	25	23.87	27.06	15	19.2	100
		20	0		27.2		31.83	35.01		27.2	
SSCPGS10-10 SSCPGS10-15 SSCPGS10-20	CP10 (3.1831)	10	+0.5		25.2	40	31.83	41.38	30	25.2	150
		15	0		35.2		47.75	54.11		35.2	
		20	0	40.2		63.66	70.03	40.2			

[Caution on Product Characteristics] ① For the center distance of the profile shifted gear, please refer to "Center distance of stock spur gear meshing with profile shifted gear" on page 60.



SSCPG 5, 10, 15, 20

CP Ground Spur Gears



Specifications	
Precision grade	JIS grade N7 (JIS B 1702-1: 1998)*
Gear teeth	Standard full depth
Pressure angle	20°
Material	S45C
Heat treatment	Gear teeth induction hardened **
Tooth hardness	50 to 60HRC
Surface treatment	Black oxide coated except for teeth

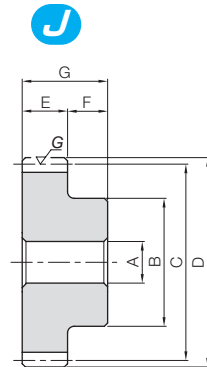

S1

* The precision grade of J Series products is equivalent to the value shown in the table.
 ** Due to the gear teeth being induction hardened, no secondary operations can be performed on tooth areas including the bottom land (approx. 2 to 3 mm).

Catalog Number	Pitch mm (Module)	No. of teeth	Shape	Bore		Pitch dia.		Outside dia.		Face width	Hub width	Total length	Distance traveled in one turn (mm)	Allowable torque (N·m)		Allowable torque (kgf·m)		Backlash (mm)	Weight (kg)	
				A _{H7}	B	C	D	E	F					G	Bending strength	Surface durability	Bending strength			Surface durability
SSCPG5-20	CP5 (1.5915)	20	S1	8	25	31.83	35.01	15	15	30	100	125	150	200	24.8	13.7	2.53	1.40	0.04~0.19	0.14
SSCPG5-25		25		10	32	39.79	42.97								33.5	23.0	3.41	2.34		
SSCPG5-30		30		10	38	47.75	50.93								42.3	35.0	4.32	3.57		
SSCPG5-40		40		12	50	63.66	66.85								60.4	66.9	6.16	6.82		
SSCPG10-20	CP10 (3.1831)	20		15	50	63.66	70.03	30	20	50	200	250	300	400	198	110	20.2	11.2	0.05~0.21	0.99
SSCPG10-25		25		20	60	79.58	85.94								268	184	27.3	18.7		
SSCPG10-30		30		20	75	95.49	101.86								339	280	34.5	28.5		
SSCPG10-40		40		25	80	127.32	133.69								483	535	49.3	54.6		
SSCPG15-25	CP15 (4.7746)	25		25	100	119.37	128.92	50	27	77	375	450	500	600	1005	667	102	68.0	0.05~0.22	5.76
SSCPG15-30		30		25	110	143.24	152.79								1270	1020	130	104		
SSCPG20-25	CP20 (6.3662)	25		30	130	159.15	171.89	60	30	90	500	600	2140	2710	2140	1470	219	150	0.05~0.22	12.0
SSCPG20-30		30		30	150	190.99	203.72								2240	2240	276	228		



Recommended mating rack



SRGCP

Please see Page 288 for more details.

Total Length G	Distance traveled in one turn (mm)	Allowable torque (N·m)		Allowable torque (kgf·m)		Backlash (mm)	Weight (kg)	Catalog Number
		Bending strength	Surface durability	Bending strength	Surface durability			
140	75	21.2	8.49	2.16	0.87	0.04~0.19	0.34 0.66	SSCPGS5-15 SSCPGS5-20
	100	32.0	16.6	3.26	1.70			
220	100	121	25.9	12.4	2.64	0.05~0.21	0.97 1.87 2.64	SSCPGS10-10 SSCPGS10-15 SSCPGS10-20
	150	169	67.9	17.3	6.93			
	200	256	133	26.1	13.6			

CP Ground Spur Gears

Recommended mating rack



SRGCP

Please see Page 288 for more details.

J Series

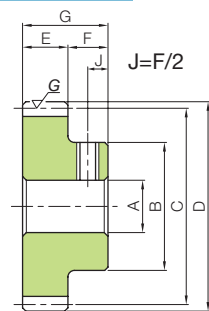

S1T

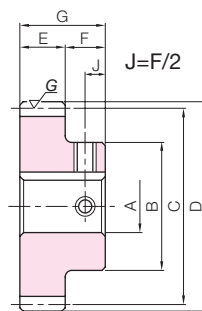

S1K



To order J Series products, please specify: **Catalog No. + J + BORE.**

Bore H7	* The product shapes of J Series items are identified by background color.																									
Keyway JS9	8	10	12	14	15	16	17	18	19	20	22	25	28	30	32	35	40	45	50	55	60	65	70	75	80	
Screw size	—	4×1.8			5×2.3				6×2.8			8×3.3			10×3.3		12×3.3	14×3.8		16×4.3	18×4.4		20×4.9		22×5.4	
Catalog Number	M5	M4				M5				M6			M8		M10		M12		M16							
SSCPG5-20 J BORE	■																									
SSCPG5-25 J BORE		■																								
SSCPG5-30 J BORE			■																							
SSCPG5-40 J BORE				■																						
SSCPG10-20 J BORE					■																					
SSCPG10-25 J BORE						■																				
SSCPG10-30 J BORE							■																			
SSCPG10-40 J BORE								■																		
SSCPG15-25 J BORE									■																	
SSCPG15-30 J BORE										■																
SSCPG20-25 J BORE											■															
SSCPG20-30 J BORE												■														

[Caution on J series] ① Cancellation is not possible for made-to-order products. See page 42 for lead times and allowable order quantities. See page 44 for other precautions.



CP Hardened Ground Racks

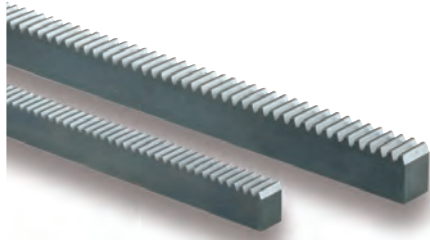

Specifications	
Precision grade	KHK R 001 Grade 3 *
Gear teeth	Standard full depth
Pressure angle	20°
Material	S45C
Heat treatment	Gear teeth induction hardened **
Tooth hardness	50 to 60HRC
Surface treatment	Black oxide coated except for teeth

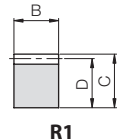
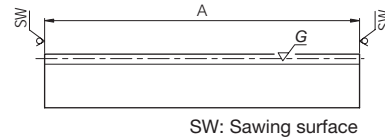

R1

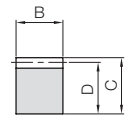
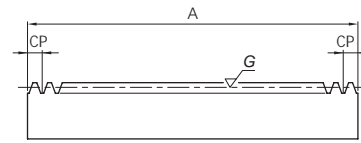

RF

* The precision grade of J Series products is equivalent to the value shown in the table.
 ** Due to the gear teeth being induction hardened, no secondary operations can be performed on tooth areas including the bottom land (approx. 2 to 3 mm).

Catalog Number	Pitch mm (Module)	Effective number of teeth	Shape	Total Length	Face width	Height	Height to pitch line	Allowable force (N)		Allowable force (kgf)	
				A	B	C	D	Bending strength	Surface durability	Bending strength	Surface durability
SRGCP5-100	CP5 (1.5915)	18	R1	98	15	20	18.41	2290	1460	233	149
SRGCP10-100	CP10 (3.1831)	8		98	30	35	31.82	9150	5860	933	597
SRGCP15-100	CP15 (4.7746)	5		103	50	50	45.23	22900	14200	2330	1450
SRGCP20-100	CP20 (6.3662)	3		98	60	60	53.63	36600	23400	3730	2390

Catalog Number	Pitch mm (Module)	No. of teeth	Shape	Total Length	Face width	Height	Height to pitch line	Allowable force (N)		Allowable force (kgf)	
				A	B	C	D	Bending strength	Surface durability	Bending strength	Surface durability
SRGCPF5-500	CP5 (1.5915)	100	RF	500	15	20	18.41	2290	1460	233	149
SRGCPF5-1000		200		1000	30	35	31.82	9150	5860	933	597
SRGCPF10-500	CP10 (3.1831)	50		500	50	50	45.23	22900	14200	2330	1450
SRGCPF10-1000		100		1000	60	60	53.63	36600	23400	3730	2390

Catalog Number	Pitch mm (Module)	No. of teeth	Shape	Total Length	Face width	Height	Height to pitch line	Mounting hole dimensions				
				A	B	C	D	E	F	G	No. of holes	Screw size
● SRGCPFD5-500J	CP5 (1.5915)	100	RD	500	15	20	18.41	8	25	150	4	M5
● SRGCPFD5-1000J		200		1000								
● SRGCPFD10-500J	CP10 (3.1831)	50		500	30	35	31.82	14	25	150	4	M10
● SRGCPFD10-1000J		100		1000								
● SRGCPFD15-1000J	CP15 (4.7746)	67	1005	50	50	45.23	20	62.5	220	5	M14	
● SRGCPFD20-1000J	CP20 (6.3662)	50	1000	60	60	53.63	23	60	220	5	M16	

[Caution on J series] ① Cancellation is not possible for made-to-order products. See page 42 for lead times and allowable order quantities. See page 44 for other precautions.

Recommended Mating Pinions



SSCP GS

Please see Page 286 for more details.



SSCP G

Please see Page 286 for more details.



J Series

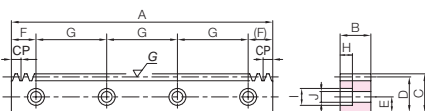

RD

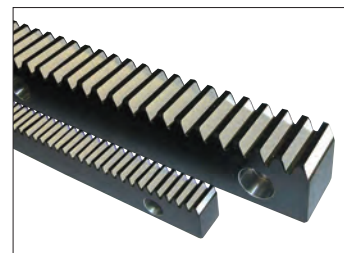

Backlash (mm)	Weight (kg)	Catalog Number
0.04~0.19	0.21	SRGCP5-100
0.05~0.21	0.73	SRGCP10-100
0.05~0.22	1.83	SRGCP15-100
0.05~0.22	2.48	SRGCP20-100

Backlash (mm)	Weight (kg)	Catalog Number
0.04~0.19	1.08 2.17	SRGCPF5-500 SRGCPF5-1000
0.05~0.21	3.75 7.49	SRGCPF10-500 SRGCPF10-1000
0.05~0.22	17.8	SRGCPF15-1000
0.05~0.22	25.3	SRGCPF20-1000

Counterbore dimensions			Allowable force (N)		Allowable force (kgf)		Backlash (mm)	Weight (kg)	Catalog Number ● : J Series (Available-on-request)
H	I	J	Bending strength	Surface durability	Bending strength	Surface durability			
6	10	6	2290	1460	233	149	0.04~0.19	1.06 2.13	● SRGCPFD5-500J ● SRGCPFD5-1000J
10.8	17.5	11	9150	5860	933	597	0.05~0.21	3.61 7.29	● SRGCPFD10-500J ● SRGCPFD10-1000J
15.2	23	16	22900	14200	2330	1450	0.05~0.22	17.3	● SRGCPFD15-1000J
17.5	26	18	36600	23400	3730	2390	0.05~0.22	24.5	● SRGCPFD20-1000J

Rack & Pinion Lubrication System

PUS lubricated spur gear



Page 492

Spur Gears

Helical Gears

Internal Gears

Racks

CP Racks & Pinions

Miter Gears

Bevel Gears

Screw Gears

Worm Gears

Gearboxes

Other Products

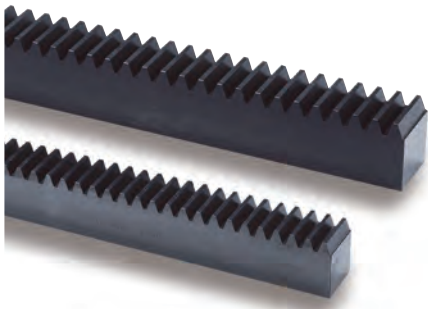

Specifications	
Precision grade	KHK R 001 grade 5 *
Gear teeth	Standard full depth
Pressure angle	20°
Material	SCM440
Heat treatment	Thermal refined, gear teeth induction hardened **
Tooth hardness	50 to 60HRC
Surface treatment	Black oxide coating

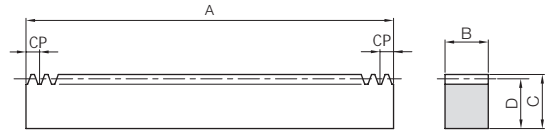

RF

* The precision grade of these products is equivalent to the value shown in the table.
 ** Due to the gear teeth being induction hardened, no secondary operations can be performed on tooth areas including the bottom land (approx. 2 to 3 mm).

Catalog Number	Pitch mm (Module)	No. of teeth	Shape	Total Length	Face width	Height	Height to pitch line	Allowable force (N)		Allowable force (kgf)	
				A	B	C	D	Bending strength	Surface durability	Bending strength	Surface durability
KRCPF5-1000H	CP5 (1.5915)	200	RF	1000	15	20	18.41	3120	1850	318	189
KRCPF10-1000H	CP10 (3.1831)	100			30	35	31.82	12500	7710	1270	786

Catalog Number	Pitch mm (Module)	No. of teeth	Shape	Total Length	Face width	Height	Height to pitch line	Mounting hole dimensions				
				A	B	C	D	E	F	G	No. of holes	Screw size
● KRCPFD5-1000HJ	CP5 (1.5915)	200	RD	1000	15	20	18.41	8	50	180	6	M5
● KRCPFD10-1000HJ	CP10 (3.1831)	100			30	35	31.82	14	50	180	6	M10

[Caution on J series] ① **Cancellation is not possible** for made-to-order products. See page 42 for lead times and allowable order quantities. See page 44 for other precautions.



J Series

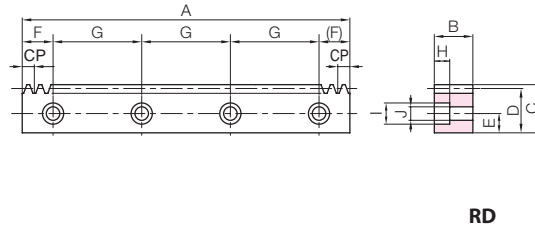

Backlash (mm)	Weight (kg)	Catalog Number
0.05~0.31	2.17	KRCPF5-1000H
0.10~0.41	7.49	KRCPF10-1000H

Counterbore dimensions			Allowable force (N)		Allowable force (kgf)		Backlash (mm)	Weight (kg)	Catalog Number ● : J Series (Available-on-request)
H	I	J	Bending strength	Surface durability	Bending strength	Surface durability			
6	10	6	3120	1850	318	189	0.05~0.31	2.13	● KRCPFD5-1000HJ
10.8	17.5	11	12500	7710	1270	786	0.10~0.41	7.29	● KRCPFD10-1000HJ

Recommended Mating Pinions



KSSCP-

Please see Page 292 for more details.

Spur Gears

Helical Gears

Internal Gears

Racks

CP Racks & Pinions

Miter Gears

Bevel Gears

Screw Gears

Worm Gears

Gearboxes

Other Products



Thermal Refined Spur Gears



Specifications	
Precision grade	JIS grade N8 (JIS B 1702-1: 1998)*
Gear teeth	Standard full depth
Pressure angle	20°
Material	SCM440
Heat treatment	Thermal refined
Tooth hardness	225 to 352HB
Surface treatment	Black oxide coating
Shape	S1

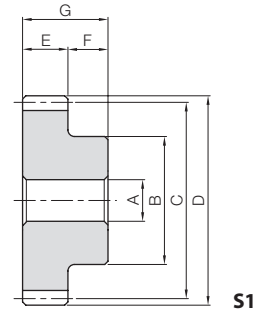

* The precision grade of J Series products is equivalent to the value shown in the table.

H To order Hardened Plus, please specify **Catalog No. + H**. Example: **KSSCP5-30H**

Catalog Number	Pitch mm (Module)	No. of teeth	Bore	Hub dia.	Pitch dia.	Outside dia.	Face width	Hub width	Total length	Distance traveled in one turn (mm)	Allowable torque						Backlash (mm)	Weight (kg)	
											Bending strength		Surface durability		Surface durability H				
											N·m	kgf·m	N·m	kgf·m	N·m	kgf·m			
KSSCP5-30	CP5 (1.5915)	30	10	38	47.75	50.93	15	15	30	150	65.8	6.71	21.0	2.15	44.3	4.52	0.09~0.27	0.33	
KSSCP5-40											93.8	9.57	41.7	4.25	86.2	8.79			0.58
KSSCP10-25	CP10 (3.1831)	25	20	60	79.58	85.94	30	20	50	250	416	42.5	117	11.9	239	24.4	0.14~0.37	1.49	
KSSCP10-30											527	53.7	182	18.6	368	37.5			2.26
KSSCP10-40											751	76.5	362	36.9	718	73.2			3.66

[Caution on Secondary Operations] ① See Page 22 for more details on Hardened Plus (H Series and HJ Series).



Thermal Refined Racks



Specifications	
Precision grade	KHK R 001 Grade 4 *
Gear teeth	Standard full depth
Pressure angle	20°
Material	SCM440
Heat treatment	Thermal refining only
Tooth hardness	225 to 352HB
Surface treatment	Black oxide coating

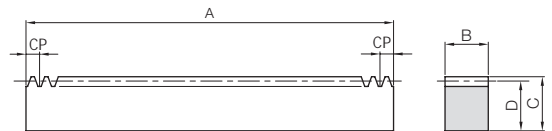

* The precision grade of J Series products is equivalent to the value shown in the table.

Catalog Number	Pitch mm (Module)	No. of teeth	Shape	Total Length	Face width	Height	Height to pitch line	Allowable force (N)		Allowable force (kgf)	
				A	B	C	D	Bending strength	Surface durability	Bending strength	Surface durability
KRCPF5-500 KRCPF5-1000	CP5 (1.5915)	100 200	RF	500 1000	15	20	18.41	3370	881	344	89.9
				500 1000							
KRCPF10-500 KRCPF10-1000	CP10 (3.1831)	50 100	RF	500 1000	30	35	31.82	13500	3820	1380	389
				500 1000							

Catalog Number	Pitch mm (Module)	No. of teeth	Shape	Total Length	Face width	Height	Height to pitch line	Mounting hole dimensions				
				A	B	C	D	E	F	G	No. of holes	Screw size
● KRCPFD5-500J ● KRCPFD5-1000J	CP5 (1.5915)	100 200	RD	500 1000	15	20	18.41	8	25 50	150 180	4 6	M5
				500 1000					25 50	150 180	4 6	
● KRCPFD10-500J ● KRCPFD10-1000J	CP10 (3.1831)	50 100	RD	500 1000	30	35	31.82	14	25 50	150 180	4 6	M10
				500 1000					25 50	150 180	4 6	

[Caution on J series] ① Cancellation is not possible for made-to-order products. See page 42 for lead times and allowable order quantities. See page 44 for other precautions.



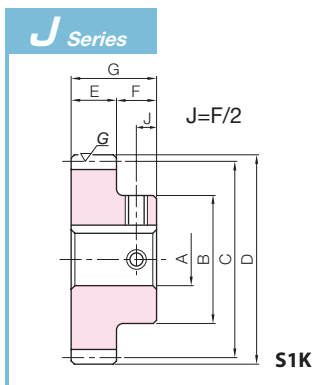

To order J Series products, please specify: **Catalog No. + J + BORE**. Example: **KSSCP5-30J10**

Bore H7	* The product shapes of J Series items are identified by background color.																			
Keyway JS9	8	10	12	14	15	16	17	18	19	20	22	25	28	30	32	35	40	45	50	
Screw size	—	4×1.8			5×2.3				6×2.8				8×3.3			10×3.3	12×3.3	14×3.8		
Catalog Number	M5	M4				M5				M6			M8			M10				
KSSCP5-30 J BORE		*																		
KSSCP5-40 J BORE			*																	
KSSCP10-25 J BORE										*										
KSSCP10-30 J BORE										*										
KSSCP10-40 J BORE										*										

To order J Series Hardened Plus products, please specify: Catalog No. + H + J + BORE. Example: KSSCP5-30HJ12

- [Caution on J series] ① Cancellation is not possible for made-to-order products. See page 42 for lead times and allowable order quantities. See page 44 for other precautions.
 ② “*” is a product with the original bore diameter, so Hardened Plus is not available. See Page 22 for more details on Hardened Plus.

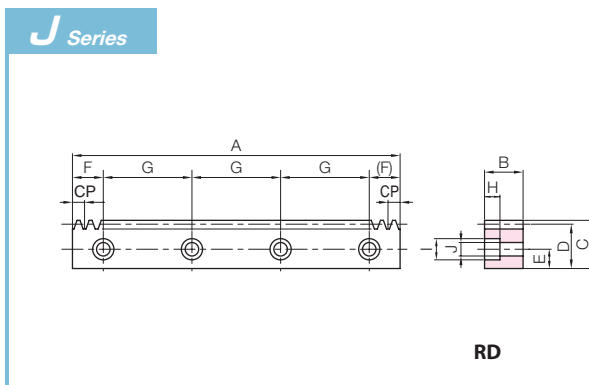

CP Thermal Refined Racks



Backlash (mm)	Weight (kg)	Catalog Number
0.09~0.27	1.08 2.17	KRCPF5-500 KRCPF5-1000
0.14~0.37	3.75 7.49	KRCPF10-500 KRCPF10-1000

Counterbore dimensions			Allowable force (N)		Allowable force (kgf)		Backlash (mm)	Weight (kg)	Catalog Number
H	I	J	Bending strength	Surface durability	Bending strength	Surface durability			
6	10	6	3370	881	344	89.9	0.09~0.27	1.06 2.13	● KRCPF5-500J ● KRCPF5-1000J
10.8	17.5	11	13500	3820	1380	389	0.14~0.37	3.61 7.29	● KRCPF10-500J ● KRCPF10-1000J



Specifications	
Precision grade	JIS grade N8 (JIS B1702-1:1998)*
Gear teeth	Standard full depth
Pressure angle	20°
Material	S45C
Heat treatment	—
Tooth hardness	(less than 194HB)
Surface treatment	Black oxide coating
Shape	S1

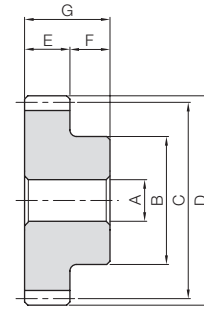

S1

* The precision grade of J Series products is equivalent to the value shown in the table.

H To order Hardened Plus, please specify **Catalog No. + H**. Example: **SSCP2.5-20H**

Catalog Number	Pitch mm (Module)	No. of teeth	Bore	Hub dia.	Pitch dia.	Outside dia.	Face width	Hub width	Total length	Distance traveled in one turn (mm)	Allowable torque						Backlash (mm)	Weight (kg)
											Bending strength		Surface durability		Surface durability H			
											N·m	kgf·m	N·m	kgf·m	N·m	kgf·m		
SSCP2.5-20	CP2.5 (0.7958)	20	6	13	15.92	17.51				50	4.14	0.42	0.48	0.049	1.60	0.16	0~0.14	0.022
SSCP2.5-30		30	8	21	23.87	25.46	10	10	20	75	7.06	0.72	1.30	0.13	4.20	0.43		
SSCP2.5-40		40	10	28	31.83	33.42				100	10.1	1.03	2.64	0.27	8.30	0.85		
SSCP5-20	CP5 (1.5915)	20	8	25	31.83	35.01				100	24.8	2.53	3.52	0.36	11.0	1.12	0.09~0.25	0.14
SSCP5-25		25	10	32	39.79	42.97	15	15	30	125	33.5	3.42	6.06	0.62	18.6	1.89		
SSCP5-30		30	10	38	47.75	50.93				150	42.3	4.32	9.45	0.96	28.6	2.92		
SSCP5-40		40	12	45	63.66	66.85				200	60.4	6.16	18.7	1.91	55.7	5.68		
SSCP10-20	CP10 (3.1831)	20	15	50	63.66	70.03				200	198	20.2	30.8	3.14	91.1	9.29	0.14~0.35	0.99
SSCP10-25		25	20	60	79.58	85.94	30	20	50	250	268	27.3	52.7	5.37	154	15.7		
SSCP10-30		30	20	75	95.49	101.86				300	339	34.5	81.7	8.33	238	24.2		
SSCP10-40		40	20	80	127.32	133.69				400	483	49.3	160	16.4	464	47.3		
SSCP15-20	CP15 (4.7746)	20	22	75	95.49	105.04				300	744	75.9	116	11.9	338	34.5	0.20~0.47	3.52
SSCP15-25		25	25	100	119.37	128.92	50	27	77	375	1000	102	199	20.3	573	58.5		
SSCP15-30		30	25	110	143.24	152.79				450	1270	130	308	31.4	885	90.2		
SSCP20-20	CP20 (6.3662)	20	25	100	127.32	140.06				400	1590	162	264	26.9	759	77.4	0.22~0.54	7.50
SSCP20-25		25	30	130	159.15	171.89	60	30	90	500	2140	219	449	45.8	1290	131		
SSCP20-30		30	30	150	190.99	203.72				600	2710	276	693	70.7	1990	202		

[Caution on Secondary Operations] ① See Page 22 for more details on Hardened Plus (H Series and HJ Series).

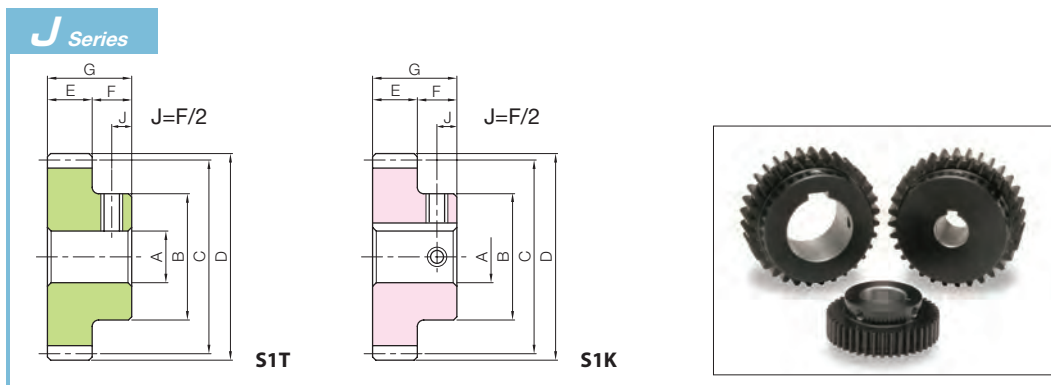

To order J Series products, please specify: **Catalog No. + J + BORE**. Example: **SSCP2.5-20J6**

* The product shapes of J Series items are identified by background color.

Bore H7	* The product shapes of J Series items are identified by background color.																												
Keyway JS9	6	8	10	12	14	15	16	17	18	19	20	22	25	28	30	32	35	40	45	50	55	60	65	70	75	80			
Screw size	-		4x1.8		5x2.3				6x2.8				8x3.3				10x3.3		12x3.3	14x3.8		16x4.3	18x4.4		20x4.9		22x5.4		
Catalog Number	M4	M5	M4				M5				M6				M8		M10	M12		M14	M16								
SSCP2.5-20 J BORE	*																												
SSCP2.5-30 J BORE		*																											
SSCP2.5-40 J BORE			*																										
SSCP5-20 J BORE		*																											
SSCP5-25 J BORE			*																										
SSCP5-30 J BORE			*																										
SSCP5-40 J BORE				*																									
SSCP10-20 J BORE					*																								
SSCP10-25 J BORE						*																							
SSCP10-30 J BORE							*																						
SSCP10-40 J BORE								*																					
SSCP15-20 J BORE									*																				
SSCP15-25 J BORE										*																			
SSCP15-30 J BORE											*																		
SSCP20-20 J BORE												*																	
SSCP20-25 J BORE													*																
SSCP20-30 J BORE														*															

To order J Series Hardened Plus products, please specify: Catalog No. + H + J + BORE. Example: **SSCP2.5-40HJ12**

[Caution on J series] ① Cancellation is not possible for made-to-order products. See page 42 for lead times and allowable order quantities. See page 44 for other precautions.
 ② "*" is a product with the original bore diameter, so Hardened Plus is not available. See Page 22 for more details on Hardened Plus.

SSCP-CP hardened spur gear recommended mating rack

SSCP CP spur gear recommended mating rack



Please see Page 296 for more details.



Please see Page 300 for more details.



CP Hardened Racks

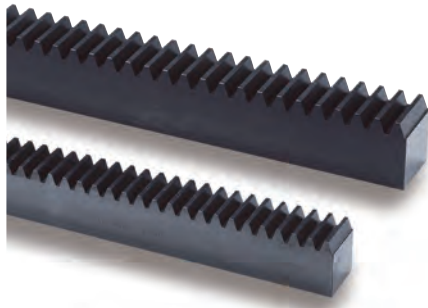

Specifications	
Precision grade	KHK R 001 grade 5 *
Gear teeth	Standard full depth
Pressure angle	20°
Material	S45C
Heat treatment	Gear teeth induction hardened **
Tooth hardness	50 to 60HRC
Surface treatment	Black oxide coating

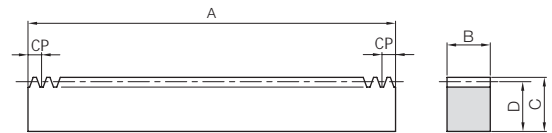

RF

* The precision grade of these products is equivalent to the value shown in the table.
 ** Due to the gear teeth being induction hardened, no secondary operations can be performed on tooth areas including the bottom land (approx. 2 to 3 mm).

Catalog Number	Pitch mm (Module)	No. of teeth	Shape	Total Length	Face width	Height	Height to pitch line	Allowable force (N)		Allowable force (kgf)	
				A	B	C	D	Bending strength	Surface durability	Bending strength	Surface durability
SRCPF5-1000H	CP5 (1.5915)	200	RF	1000	15	20	18.41	2080	1200	212	122
SRCPF10-1000H	CP10 (3.1831)	100		1000	30	35	31.82	8320	4980	848	508
SRCPF15-1000H	CP15 (4.7746)	67		1005	50	50	45.23	20800	12400	2120	1260
SRCPF20-1000H	CP20 (6.3662)	50		1000	60	60	53.63	33300	20800	3390	2120

Catalog Number	Pitch mm (Module)	No. of teeth	Shape	Total Length	Face width	Height	Height to pitch line	Mounting hole dimensions				
				A	B	C	D	E	F	G	No. of holes	Screw size
● SRCPFD5-1000HJ	CP5 (1.5915)	200	RD	1000	15	20	18.41	8	50	180	6	M5
● SRCPFD10-1000HJ	CP10 (3.1831)	100		1000	30	35	31.82	14	50	180	6	M10
● SRCPFD15-1000HJ	CP15 (4.7746)	67		1005	50	50	45.23	20	62.5	220	5	M14
● SRCPFD20-1000HJ	CP20 (6.3662)	50		1000	60	60	53.63	23	60	220	5	M16

[Caution on J series] ① Cancellation is not possible for made-to-order products. See page 42 for lead times and allowable order quantities. See page 44 for other precautions.



J Series

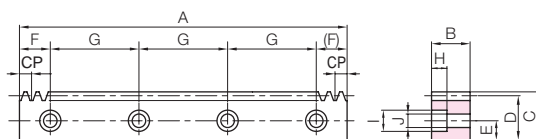

RD



Backlash (mm)	Weight (kg)	Catalog Number
0.05~0.29	2.17	SRCPF5-1000H
0.10~0.39	7.49	SRCPF10-1000H
0.16~0.51	17.8	SRCPF15-1000H
0.18~0.58	25.3	SRCPF20-1000H

Counterbore dimensions			Allowable force (N)		Allowable force (kgf)		Backlash (mm)	Weight (kg)	Catalog Number ● : J Series (Available-on-request)
H	I	J	Bending strength	Surface durability	Bending strength	Surface durability			
6	10	6	2080	1200	212	122	0.05~0.29	2.13	● SRCPFD5-1000HJ
10.8	17.5	11	8320	4980	848	508	0.10~0.39	7.29	● SRCPFD10-1000HJ
15.2	23	16	20800	12400	2120	1260	0.16~0.51	17.3	● SRCPFD15-1000HJ
17.5	26	18	33300	20800	3390	2120	0.18~0.58	24.5	● SRCPFD20-1000HJ

Recommended Mating Pinions



SSCP-

Please see Page 294 for more details.

Spur Gears

Helical Gears

Internal Gears

Racks

CP Racks & Pinions

Miter Gears

Bevel Gears

Screw Gears

Worm Gears

Gearboxes

Other Products



CP Laser Hardened Racks

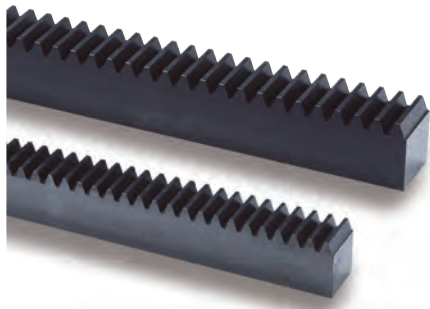

Specifications	
Precision grade	KHK R 001 Grade 4 *
Gear teeth	Standard full depth
Pressure angle	20°
Material	S45C
Heat treatment	Gear teeth laser hardened **
Tooth hardness	55 to 65HRC
Surface treatment	Black oxide coating

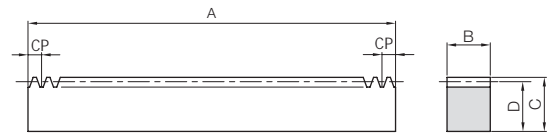

RF

* The precision grade of these products is equivalent to the value shown in the table.
 ** Due to the gear teeth being laser hardened, no secondary operations can be performed on tooth areas including the bottom land (approx. 1 mm).

Catalog Number	Pitch mm (Module)	No. of teeth	Shape	Total Length	Face width	Height	Height to pitch line	Allowable force (N)		Allowable force (kgf)	
				A	B	C	D	Bending strength	Surface durability	Bending strength	Surface durability
SRCPF5-1000HL	CP5 (1.5915)	200	RF	1000	15	20	18.41	2290	1040	232	106
SRCPF5-1500HL		300		1500							
SRCPF5-2000HL		410		2050							
SRCPF10-1000HL	CP10 (3.1831)	100		1000	30	35	31.82	9150	4330	933	441
SRCPF10-1500HL		150		1500							
SRCPF10-2000HL		205		2050							
SRCPF15-1000HL	CP15 (4.7746)	67		1005	50	50	45.23	22900	10700	2333	1095
SRCPF15-1500HL		100		1500							
SRCPF15-2000HL		136		2040							
SRCPF20-1000HL	CP20 (6.3662)	50		1000	60	60	53.63	36600	18100	3732	1843
SRCPF20-1500HL		75		1500							
SRCPF20-2000HL		102		2040							

Catalog Number	Pitch mm (Module)	No. of teeth	Shape	Total Length	Face width	Height	Height to pitch line	Mounting hole dimensions						
				A	B	C	D	E	F	G	No. of holes	Screw size		
● SRCPFD5-1000HLJ	CP5 (1.5915)	200	RD	1000	15	20	18.41	8	50	180	6	M5		
● SRCPFD5-1500HLJ		300		1500									30	9
● SRCPFD5-2000HLJ		410		2050									35	12
● SRCPFD10-1000HLJ	CP10 (3.1831)	100		1000	30	35	31.82	14	50	180	6	M10		
● SRCPFD10-1500HLJ		150		1500									30	9
● SRCPFD10-2000HLJ		205		2050									35	12
● SRCPFD15-1000HLJ	CP15 (4.7746)	67		1005	50	50	45.23	20	62.5	220	5	M14		
● SRCPFD15-1500HLJ		100		1500									30	7
● SRCPFD15-2000HLJ		136		2040									30	10
● SRCPFD20-1000HLJ	CP20 (6.3662)	50		1000	60	60	53.63	23	60	220	5	M16		
● SRCPFD20-1500HLJ		75		1500									30	7
● SRCPFD20-2000HLJ		102		2040									30	10

[Caution on J series] ① Cancellation is not possible for made-to-order products. See page 42 for lead times and allowable order quantities. See page 44 for other precautions.



J Series

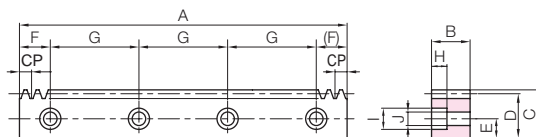

RD



Backlash (mm)	Weight (kg)	Catalog Number
0.09~0.25	2.17	SRCPF5-1000HL
	3.25	SRCPF5-1500HL
	4.44	SRCPF5-2000HL
0.14~0.35	7.49	SRCPF10-1000HL
	11.2	SRCPF10-1500HL
	15.4	SRCPF10-2000HL
0.20~0.47	17.8	SRCPF15-1000HL
	26.6	SRCPF15-1500HL
	36.2	SRCPF15-2000HL
0.22~0.54	25.3	SRCPF20-1000HL
	37.9	SRCPF20-1500HL
	51.5	SRCPF20-2000HL

Counterbore dimensions			Allowable force (N)		Allowable force (kgf)		Backlash (mm)	Weight (kg)	Catalog Number ● : J Series (Available-on-request)
H	I	J	Bending strength	Surface durability	Bending strength	Surface durability			
6	10	6	2290	1040	232	106	0.09~0.25	2.13	● SRCPFD5-1000HLJ ● SRCPFD5-1500HLJ ● SRCPFD5-2000HLJ
								3.20	
								4.38	
10.8	17.5	11	9150	4330	933	441	0.14~0.35	7.29	● SRCPFD10-1000HLJ ● SRCPFD10-1500HLJ ● SRCPFD10-2000HLJ
								10.9	
								14.9	
15.2	23	16	22900	10700	2333	1095	0.20~0.47	17.3	● SRCPFD15-1000HLJ ● SRCPFD15-1500HLJ ● SRCPFD15-2000HLJ
								25.9	
								35.2	
17.5	26	18	36600	18100	3732	1843	0.22~0.54	24.5	● SRCPFD20-1000HLJ ● SRCPFD20-1500HLJ ● SRCPFD20-2000HLJ
								36.8	
								50.0	

Recommended Mating Pinions



SSCP-

Please see Page 294 for more details.



CP Racks



Spur Gears
Helical Gears
Internal Gears
Racks
CP Racks & Pinions
Miter Gears
Bevel Gears
Screw Gears
Worm Gears
Gearboxes
Other Products



Specifications	
Precision grade	KHK R 001 Grade 4 *
Gear teeth	Standard full depth
Pressure angle	20°
Material	S45C
Heat treatment	—
Tooth hardness	(less than 210HB)
Surface treatment	Black oxide coating

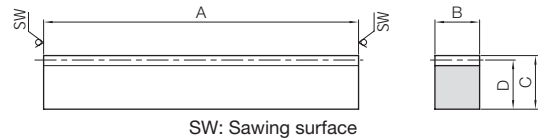

R1

* The precision grade of J Series products is equivalent to the value shown in the table.

Catalog Number	Pitch mm (Module)	Effective number of teeth	Shape	Total Length				Allowable force (N)		Allowable force (kgf)		Backlash (mm)	Weight (kg)
				A	B	C	D	Bending strength	Surface durability	Bending strength	Surface durability		
SRCP2.5-100	CP2.5 (0.7958)	38	R1	98	10	12	11.2	763	143	77.8	14.5	0.00~0.14	0.086
SRCP5-100	CP5 (1.5915)	18		98	15	20	18.41	2290	468	233	47.7	0.09~0.25	0.21
SRCP10-100	CP10 (3.1831)	8		98	30	35	31.82	9150	1870	933	191	0.14~0.35	0.73
SRCP15-100	CP15 (4.7746)	5		103	50	50	45.23	22900	4530	2330	462	0.20~0.47	1.83
SRCP20-100	CP20 (6.3662)	3		98	60	60	53.63	36600	7480	3730	763	0.22~0.54	2.48

Catalog Number	Pitch mm (Module)	No. of teeth	Shape	Total Length				Allowable force (N)		Allowable force (kgf)		Backlash (mm)	Weight (kg)	
				A	B	C	D	Bending strength	Surface durability	Bending strength	Surface durability			
SRCPF2.5-500	CP2.5 (0.7958)	200	RF	500	10	12	11.2	763	143	77.8	14.5	0.00~0.14	0.44	
SRCPF2.5-1000		400		1000										0.88
SRCPF5-500	CP5 (1.5915)	100		500	15	20	18.41	2290	468	233	47.7	0.09~0.25	1.08	
SRCPF5-1000		200		1000										2.17
SRCPF5-1500		300		1500										3.25
SRCPF5-2000		410		2050										4.44
SRCPF10-500	CP10 (3.1831)	50		500	30	35	31.82	9150	1870	933	191	0.14~0.35	3.75	
SRCPF10-1000		100		1000										7.49
SRCPF10-1500		150		1500										11.2
SRCPF10-2000		205		2050										15.4
SRCPF15-1000	CP15 (4.7746)	67	1005	50	50	45.23	22900	4530	2330	462	0.20~0.47	17.8		
SRCPF15-1500		100	1500										26.6	
SRCPF15-2000		136	2040										36.2	
SRCPF20-1000	CP20 (6.3662)	50	1000	60	60	53.63	36600	7480	3730	763	0.22~0.54	25.3		
SRCPF20-1500		75	1500										37.9	
SRCPF20-2000		102	2040										51.5	

Catalog Number	Pitch mm (Module)	No. of teeth	Shape	Total Length	Face width	Height	Height to pitch line	Mounting hole dimensions					
				A	B	C	D	E	F	G	No. of holes	Screw size	
● SRCPFK2.5-500J	CP2.5 (0.7958)	200	RA	500	10	12	11.2	5	25	150	4	M4	
● SRCPFD5-500J	CP5 (1.5915)	100	RD	500	15	20	18.41	8	25	150	4	M5	
● SRCPFD5-1000		200		1000									6
● SRCPFD5-1500		300		1500									9
● SRCPFD5-2000		410		2050									12
● SRCPFD10-500J	CP10 (3.1831)	50		500	30	35	31.82	14	25	150	4	M10	
● SRCPFD10-1000		100		1000									6
● SRCPFD10-1500		150		1500									9
● SRCPFD10-2000		205		2050									12
SRCPFD15-1000	CP15 (4.7746)	67		1005	50	50	45.23	20	62.5	220	5	M14	
SRCPFD15-1500		100		1500					7				
SRCPFD15-2000		136	2040	10									
SRCPFD20-1000	CP20 (6.3662)	50	1000	60	60	53.63	23	60	220	5	M16		
SRCPFD20-1500		75	1500					7					
SRCPFD20-2000		102	2040					10					

[Caution on Secondary Operations] ① Avoid hardening racks with bolt holes, due to mounting hole deformation.

[Caution on J series] ① Cancellation is not possible for made-to-order products. See page 42 for lead times and allowable order quantities. See page 44 for other precautions.

J Series

Recommended Mating Pinions



SSCP

Please see Page 294 for more details.

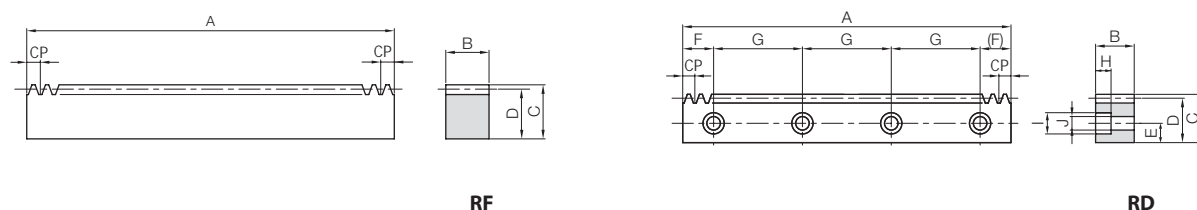
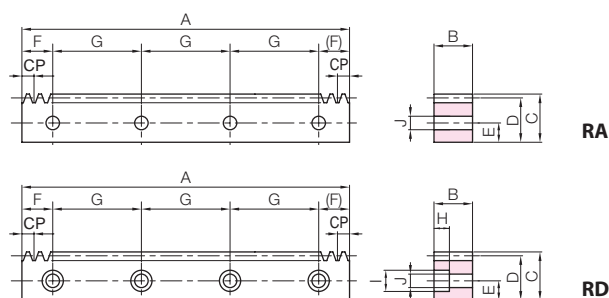

RF

RD

Counterbore dimensions			Allowable force (N)		Allowable force (kgf)		Backlash (mm)	Weight (kg)	Catalog Number ● : J Series (Available-on-request)
H	I	J	Bending strength	Surface durability	Bending strength	Surface durability			
-	-	4.5	763	143	77.8	14.5	0.00~0.14	0.43	●SRCPFK2.5-500J
6	10	6	2290	468	233	47.7	0.09~0.25	1.06 2.13 3.20 4.38	●SRCPFD5-500J SRCPFD5-1000 SRCPFD5-1500 SRCPFD5-2000
10.8	17.5	11	9150	1870	933	191	0.14~0.35	3.61 7.29 10.9 14.9	●SRCPFD10-500J SRCPFD10-1000 SRCPFD10-1500 SRCPFD10-2000
15.2	23	16	22900	4530	2330	462	0.20~0.47	17.3 25.9 35.2	SRCPFD15-1000 SRCPFD15-1500 SRCPFD15-2000
17.5	26	18	36600	7480	3730	763	0.22~0.54	24.5 36.8 50.0	SRCPFD20-1000 SRCPFD20-1500 SRCPFD20-2000

Spur Gears

Helical Gears

Internal Gears

Racks

CP Racks & Pinions

Miter Gears

Bevel Gears

Screw Gears

Worm Gears

Gearboxes

Other Products



Stainless Steel Spur Gears



Specifications	
Precision grade	JIS grade N8 (JIS B1702-1: 1998)*
Gear teeth	Standard full depth
Pressure angle	20°
Material	SUS303
Heat treatment	—
Tooth hardness	(less than 187HB)

* The precision grade of J Series products is equivalent to the value shown in the table.

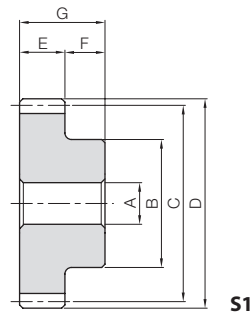

S1

Spur Gears

Helical Gears

Internal Gears

Racks

Catalog Number	Pitch mm (Module)	No. of teeth	Shape	Bore AH7	Hub dia. B	Pitch dia. C	Outside dia. D	Face width E	Hub width F	Total length G	Distance traveled in one turn (mm)	Allowable torque (N·m)		Allowable torque (kgf·m)		Backlash (mm)	Weight (kg)
												Bending strength	Surface durability	Bending strength	Surface durability		
SUSCP5-20	CP5 (1.5915)	20	S1	8	25	31.83	35.01	15	15	30	100	13.7	2.50	1.40	0.25	0.09~0.27	0.14
SUSCP5-25		25		10	32	39.78	42.97					18.5	4.31	1.89	0.44		
SUSCP5-30		30		10	38	47.74	50.93					23.4	6.72	2.39	0.68		
SUSCP10-20	CP10 (3.1831)	20	S1	15	50	63.66	70.03	30	20	50	200	110	21.9	11.2	2.23	0.14~0.37	1.00
SUSCP10-30		30		20	75	95.49	101.86					187	58.0	19.1	5.92		

CP Racks & Pinions

Miter Gears



Stainless Steel Racks



Specifications	
Precision grade	KHK R 001 Grade 5 *
Gear teeth	Standard full depth
Pressure angle	20°
Material	SUS304
Heat treatment	Solution treated
Tooth hardness	(less than 187HB)

* The precision grade of J Series products is equivalent to the value shown in the table.

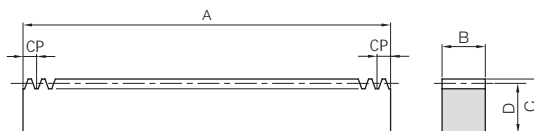

RF

Bevel Gears

Screw Gears

Worm Gears

Catalog Number	Pitch mm (Module)	No. of teeth	Shape	Total Length	Face width	Height	Height to pitch line	Allowable force (N)		Allowable force (kgf)	
				A	B	C	D	Bending strength	Surface durability	Bending strength	Surface durability
SURCPF5-500 SURCPF5-1000	CP5 (1.5915)	100	RF	500	15	20	18.41	1090	263	111	26.8
200		1000									
SURCPF10-500 SURCPF10-1000	CP10 (3.1831)	50	RF	500	30	35	31.82	4370	1050	445	107
100		1000									

Catalog Number	Pitch mm (Module)	No. of teeth	Shape	Total Length	Face width	Height	Height to pitch line	Mounting hole dimensions				
				A	B	C	D	E	F	G	No. of holes	Screw size
SURCPFD5-500J SURCPFD5-1000	CP5 (1.5915)	100	RD	500	15	20	18.41	8	25	150	4	M5
200		1000										
SURCPFD10-500J SURCPFD10-1000	CP10 (3.1831)	50	RD	500	30	35	31.82	14	25	150	4	M10
100		1000										

[Caution on Product Characteristics] ① The stainless steel material is given *solution treatment and **passivation. Passivation improves the anti-rust performance, but it is not effective on the processed surface of the product. Note that this product is not completely rustproof.

* Solution treatment

Heat treatment by melting the carbide generated on the surface into the material when manufacturing the material

** Passivation

Pickled (nitric hydrofluoric acid) to make it more rust resistant



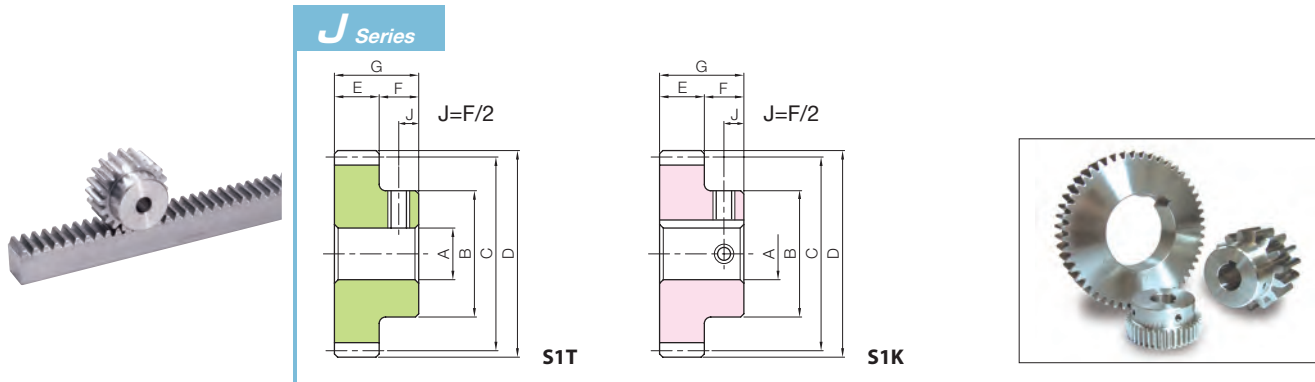

Spur Gears

Helical Gears

Internal Gears

Racks

CP Racks & Pinions

Miter Gears

Bevel Gears

Screw Gears

Worm Gears

Gearboxes

Other Products

To order J Series products, please specify: **Catalog No. + J + BORE.**

Bore H7		* The product shapes of J Series items are identified by background color.																	
Keyway JS9		8	10	12	14	15	16	17	18	19	20	22	25	28	30	32	35	40	45
Screw size		4x1.8		5x2.3				6x2.8				8x3.3			10x3.3		12x3.3		14x3.8
Catalog Number		M5		M4				M5				M6			M8		M10		
SUSCP5-20 J BORE																			
SUSCP5-25 J BORE																			
SUSCP5-30 J BORE																			
SUSCP10-20 J BORE																			
SUSCP10-30 J BORE																			

[Caution on J series] ① Cancellation is not possible for made-to-order products. See page 42 for lead times and allowable order quantities. See page 44 for other precautions.

CP Stainless Steel Racks

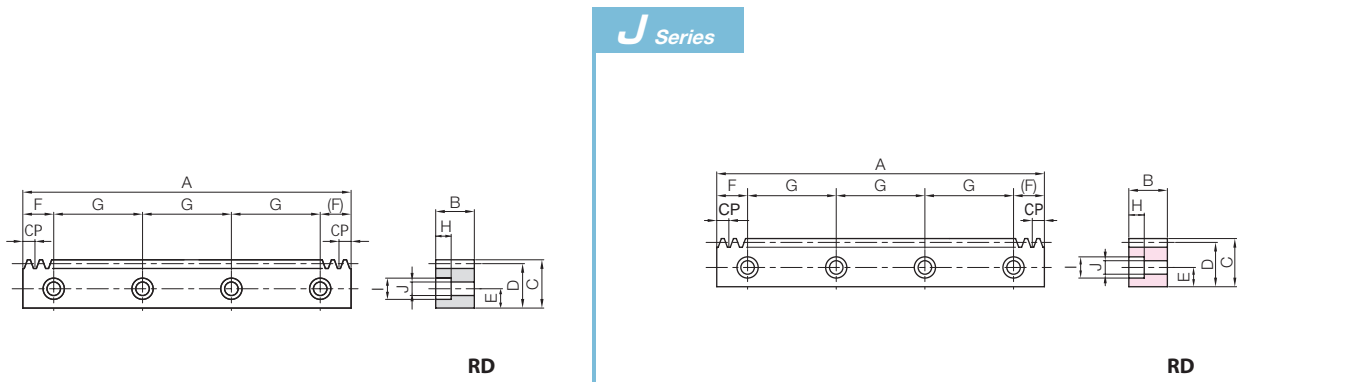

Backlash (mm)	Weight (kg)	Catalog Number
0.09~0.27	1.09	SURCPF5-500
	2.19	SURCPF5-1000
0.14~0.37	3.78	SURCPF10-500
	7.57	SURCPF10-1000

Counterbore dimensions			Allowable force (N)		Allowable force (kgf)		Backlash (mm)	Weight (kg)	Catalog Number ● : J Series (Available-on-request)
H	I	J	Bending strength	Surface durability	Bending strength	Surface durability			
6	10	6	1090	263	111	26.8	0.09~0.27	1.07 2.16	● SURCPFD5-500J ● SURCPFD5-1000
10.8	17.5	11	4370	1050	445	107	0.14~0.37	3.65 7.36	● SURCPFD10-500J ● SURCPFD10-1000

[Caution on J series] ① Cancellation is not possible for made-to-order products. See page 42 for lead times and allowable order quantities. See page 44 for other precautions.



Spur Gears
 Helical Gears
 Internal Gears
 Racks
 CP Racks & Pinions
 Miter Gears
 Bevel Gears
 Screw Gears
 Worm Gears
 Gearboxes
 Other Products



Specifications	
Precision grade	KHK R 001 grade 4
Gear teeth	Standard full depth
Pressure angle	20°
Material	S45C
Heat treatment	—
Tooth hardness	(less than 210HB)
Surface treatment	Black oxide coating

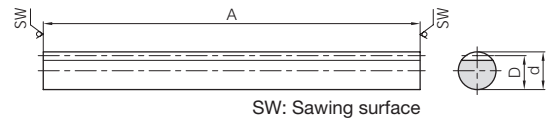

R2

Catalog Number	Pitch mm (Module)	Effective number of teeth	Shape	Total Length	Outside dia.	Height to pitch line	Allowable force (N)		Allowable force (kgf)		Backlash (mm)	Weight (kg)
				A	d _{h9}	D	Bending strength	Surface durability	Bending strength	Surface durability		
SROCP2.5-500	CP2.5 (0.7958)	200	R2	505	10	9.2	474	91.8	48.3	9.36	0.00~0.14	0.30
SROCP5-500	CP5 (1.5915)	99		505	15	13.41	1650	324	169	33.1	0.09~0.25	0.65
SROCP10-1000	CP10 (3.1831)	99		1010	30	26.82	6610	1300	674	132	0.14~0.35	5.16

[Caution on Product Characteristics] ① Because this is extruded material, the outer diameter may be out of H9 tolerance in sections.

[Caution on Secondary Operations] ① Avoid hardening round racks, due to twisting and deformation occurring and the difficulty of straightening the rack after hardening.



Specifications	
Precision grade	KHK R 001 grade 8
Gear teeth	Standard full depth
Pressure angle	20°
Material	SS400
Heat treatment	—
Tooth hardness	(less than 187HB)
Surface treatment	Black oxide coating

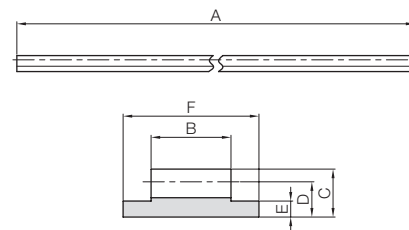

R3

Catalog Number	Pitch mm (Module)	Shape	Total Length	Face width	Height	Height to pitch line	Base thickness	Base width	Allowable force (N)		Allowable force (kgf)		Weight (kg)
			A	B	C	D	E	F	Bending strength	Bending strength	Bending strength	Bending strength	
FRCP5-2000 *	CP5 (1.5915)	R3	2000	10	6	4.41	2	17	801	81.7	81.7	81.7	0.91
FRCP5-3000 *			3000										1.37
FRCP5-4000 *			4000										1.83

[Caution on Product Characteristics] ① When using the metal flexible rack in an arc, the minimum bending radius (R) is 150 mm for both the external and internal teeth.

Using a smaller radius increases the pitch errors and tooth profile errors which prevent the teeth from meshing at the normal center distance, so be sure to make adjustments before use.

- ② The tolerance of height (size C) is 0 to -0.15, and the tolerance of base width (size F) is 0 to -0.1.
- ③ It cannot be used where positioning accuracy is required.

Installation Example of FRCP Metal Flex Rack

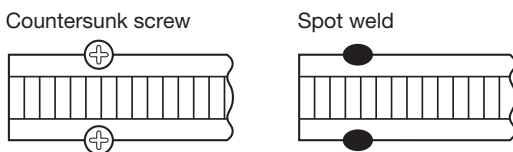

(View of Flexible Rack from the top)

Recommended Mating Pinions



SSCP

Please see Page 294 for more details.

⦿ Note that products with an asterisk (*) after the catalog number will no longer be manufactured after 20 June, 2026.