

KHK

The ABCs of Gears

A - The Introductory Course



A water mill at Shirakawago World Heritage Site (still in active service)



Cogwheels used as object d'art (by a certain clock maker)



A tea serving doll

KOHARA GEAR INDUSTRY CO., LTD.

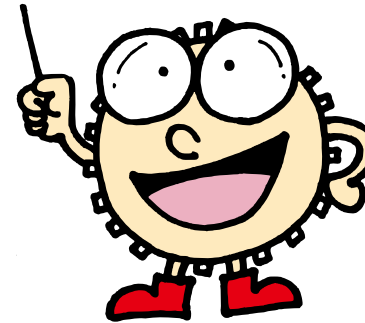

Hi! How are you? Oh, my name? Well, people call me Uncle Gear. Well, I'm going to tell you something very important about gears. Are you ready? First, KHK prepared a series of brochure titled "The ABCs of Gears". It consists of A - the introductory course, B - the intermediate course, and C - the advanced course. In this course A, I'll put you onto the role of gears, their history, and how to make them. I'd be happy if you watch for the following issues - B and C courses. Now, let's get started.

Contents

1. Let's Search for a Gear	P2
2. History of Gears	P4
3. Gears as a Machine Element	P8
4. About Gear Mates	P10
5. The Role of Gears	P12
6. Types of Gears	P14
7. Fundamental Gear Terms	P18
8. Gear Materials and Heat Treatment	P22
9. Gear Accuracy and Strength	P24
10. How to Make Gears	P26
11. Gears Are Ubiquitous	P32

1. Let's Search for a Gear

You must have seen one as they are everywhere.

I'm sure you once used to play with your toys. Toys usually contain a lot of gears. Let's look at some of them.

■ Radio-controlled model car



Gears transmitting power and motion to the tires.

■ Top

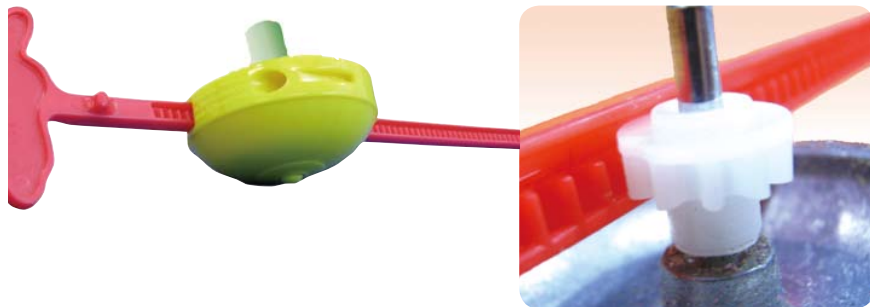

A belt-shaped rack and a gear to spin the top

Look at these things in your kitchen, and you'll find some.

■ Coffee Mill



A pair of bevel gears to turn the mill

■ Hand-mixer



A gear to turn the mixer

2. History of Gears

Maybe you want to know how far gears date back to.

Here's the answer.

Gears were already in use in 350 B.C. (about 2,300 years ago). You probably know about a Greek philosopher Aristotle (384~322 B.C.). One of Aristotle's writings includes a description about a gear. A hundred years later that day, a Hellenistic mathematician Archimedes (287~212 B.C.) drew a diagram of a hoist (See the diagram on the right) that was driven with a set of worm and worm wheel.

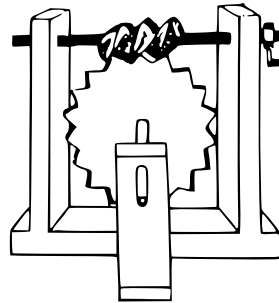

Ancient gears at the Ctesiphon archeological site in Iraq

Here in Japan, as seen from the picture below, gears were in use in the Edo period (1603~1867) as a power source for flour milling in waterwheels. The gear was as large as one meter in diameter, and zelkova and oak trees were used as the material.

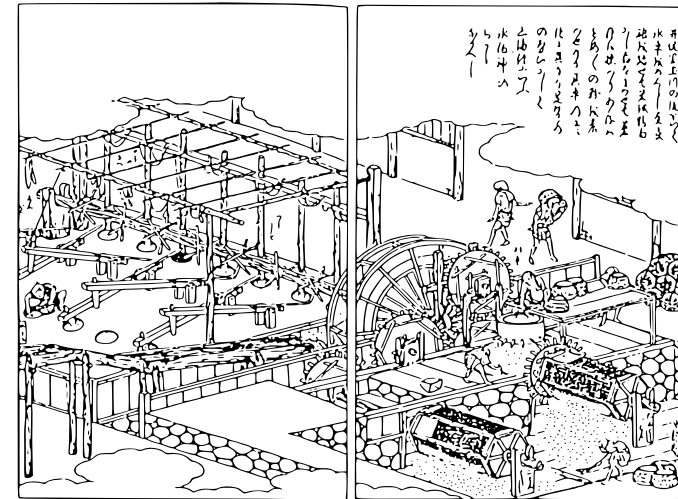







A waterwheel in the countryside from an old illustration (1786)

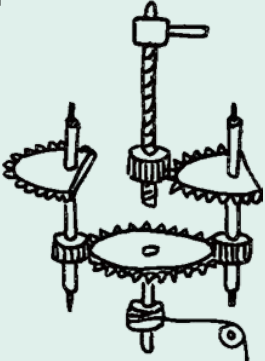

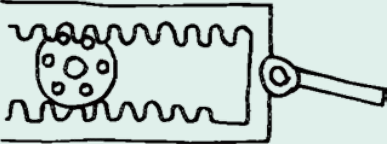



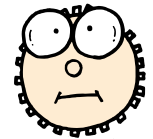

A waterwheel, Kasumigaura park, Tsuchiura, Ibaraki Prefecture

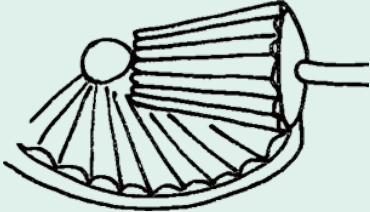
An Italian mathematician, Leonardo da Vinci (1451~1519), who can be described as a true "Renaissance man," recorded in notebooks numerous drawings. See those sketchings he had left, and I'm sure you'll find he is absolutely worthy of special mention in the gear history.

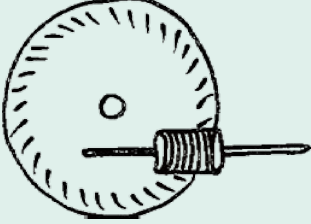
Leonardo's sketching (500 years ago)	KHK Stock Gears (the present)
<p>■ Spur Gear</p> 	
<p>■ Rack & Pinion</p> 	
<p>■ Screw Gear</p> 	

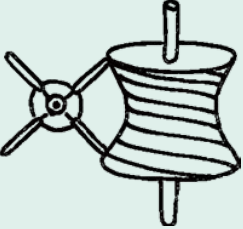

Leonardo's sketching (500 years ago)	KHK Stock Gears (the present)
<p>■ Bevel Gear</p> 	
<p>■ High-ratio Hypoid Gear</p> 	
<p>■ Worm & Worm Wheel</p> 	

3. Gears as a Machine Element

You'll find it amazing that a machine is made of various parts.

Here's an electric drill a do-it-yourselfer can't do without. Let's see the inside after loosening the bolts and removing the cover.

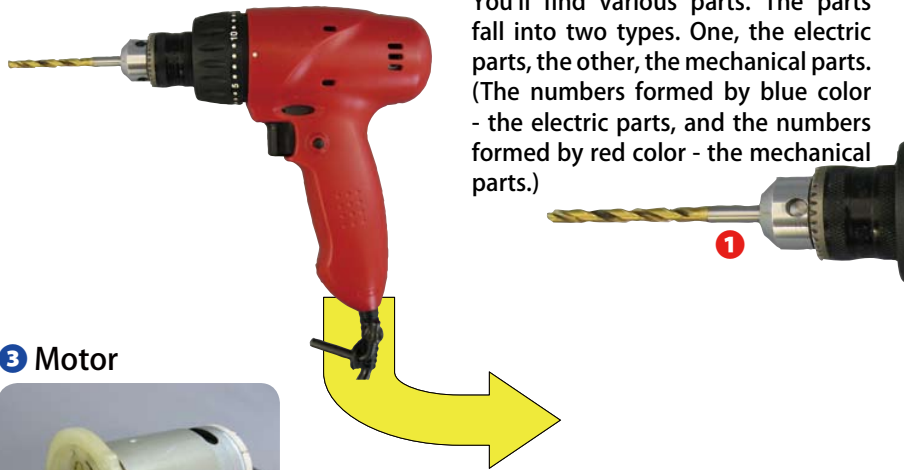

You'll find various parts. The parts fall into two types. One, the electric parts, the other, the mechanical parts. (The numbers formed by blue color - the electric parts, and the numbers formed by red color - the mechanical parts.)

3 Motor



4 Switch



5 Capacitor

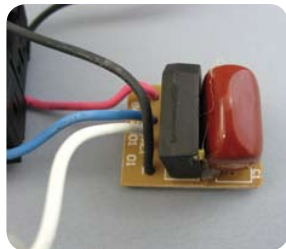

6 Power supply cord



1 Collet chuck



2 Planetary Gear System



A set of bevel gears is used to hold a drill rod.

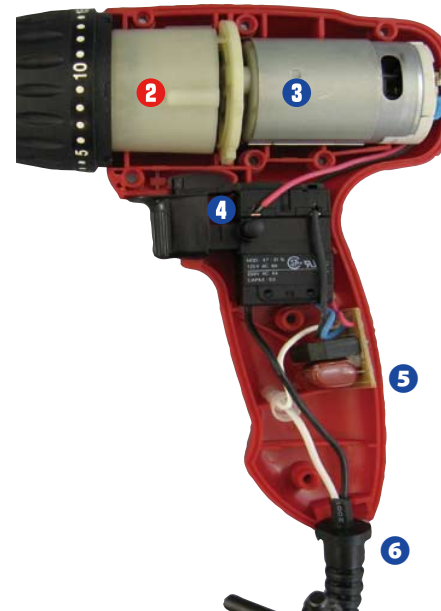

The collet chuck and the gears found here are called "Machine elements." Any of the elementary mechanical parts, such as bearings, screws, springs, and bolts falls into this category.

The planetary gear system transmits the mechanical energy from motor to a drill rod reducing the rotational speed and increasing torque.

4. About Gear Mates

Now, shall we move on to the next topic - about our mates, all right?

Cited here are our mates, namely, driveline components that are used to transmit power and motion like ourselves.

■ Synchronous belt pulley, or drive pulley / Synchronous belt



■ Sprocket wheel / Roller chain



■ V-belt pulley / V-belt



These three are called "wrapping connector drive." Compared to these wrapping connector drive, gears have strong points such as:

- Relatively simple in construction.
- Capable of transmitting power with uniform motion and reliability.
- Have long service lives.
- Power losses are minimal.

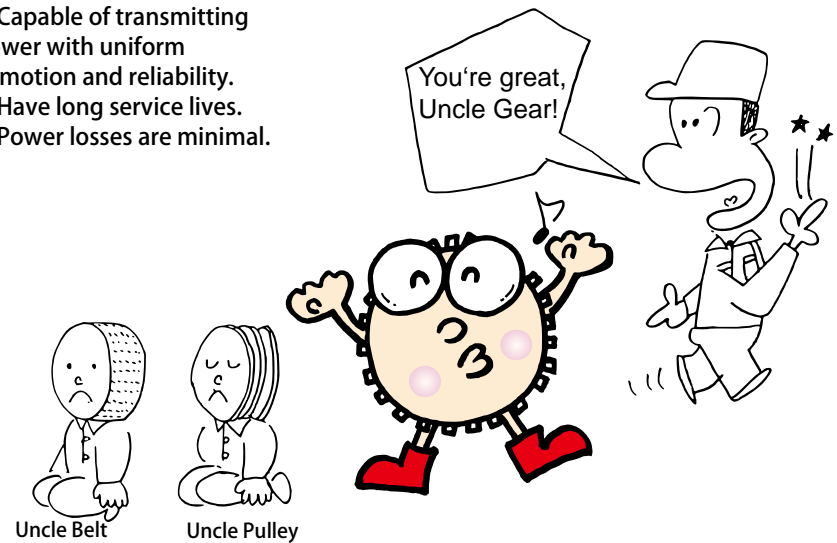

5. The Role of Gears

Let's see what gears can do. I'm sure you'll feel they are all-arounders.

Gears work in pairs to do a job. They can:

■ Transmit motion and power between rotating shafts.

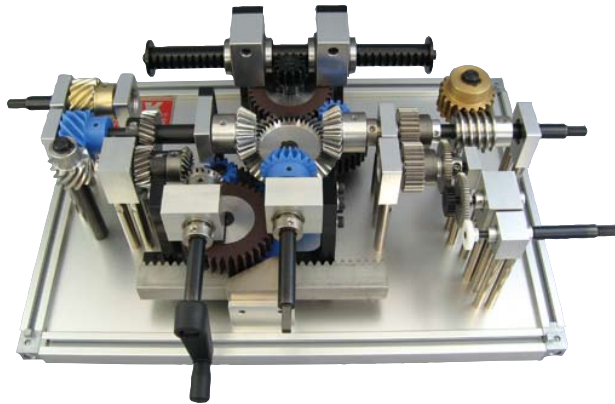

■ Change the direction of rotation and speed

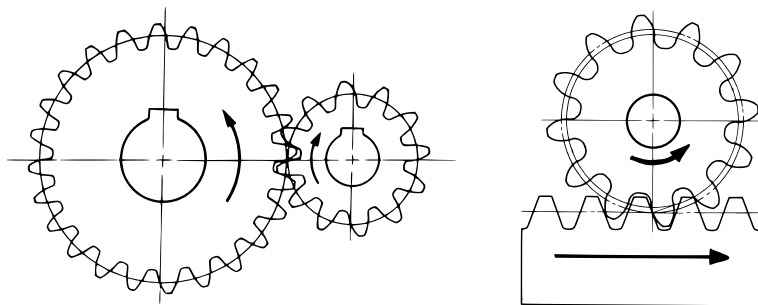

In any pair of gears, the larger gear will move more slowly than the smaller gear. Gears tend to change rotational directions.

■ Configuration

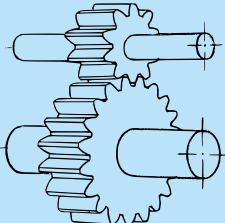
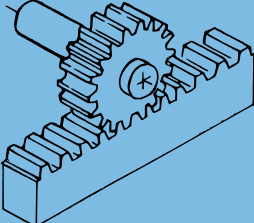
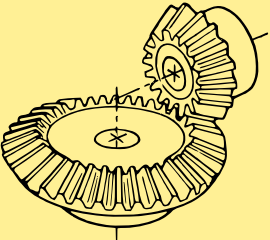
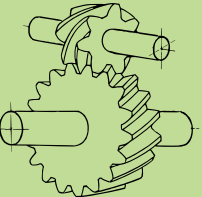
<p>Parallel axes</p> 	<p>Transmit power and motion between parallel shafts.</p> <p>Spur gears and helical gears are used.</p>
	<p>Change the rotary motion into the rectilinear motion and vice versa.</p> <p>A combination of spur gear and rack or a combination of helical gear and helical rack is needed to do work.</p>
<p>Intersecting axes</p> 	<p>Transmit power and motion between intersecting shafts at right (90°) angles.</p> <p>Straight bevel gears or Spiral bevel gears are used.</p>
<p>Nonparallel, nonintersecting axes</p> 	<p>Transmit motion and power between nonparallel, nonintersecting shafts that are usually at right angles (90°).</p> <p>Screw gears and worm gear pair are used.</p>

6. Types of Gears

Now, I'd like you to meet my family. Here they are!



**Gears used to drive parallel axes.
(For rotary motion)**

Gears to transmit the rotary motion and power between two parallel shafts.

★ MSGA Ground Spur Gear



★ SS Steel Spur Gear



★ PS Plastic Spur Gear



★ SUS Stainless Steel Spur Gear



★ KHG Ground Helical Gear



★ BSS Brass Spur Gear



**Gears used to drive parallel axes
(For rectilinear motion)**

Gears to change the rotary motion into the rectilinear motion.

★ SRGF Ground Rack



★ KRHG Ground Helical Rack

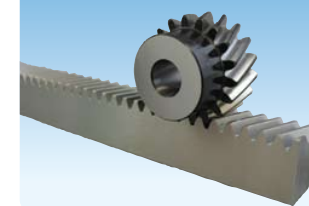

★ SR Rack



★ PR Plastic Rack

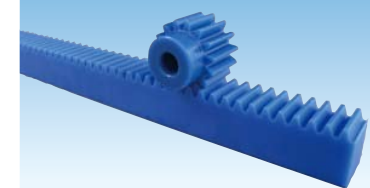

★ BSR Brass Rack

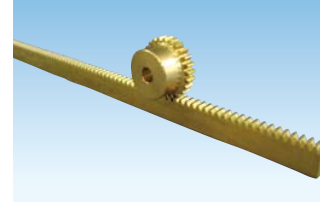

★ DR Molded Flexible Rack

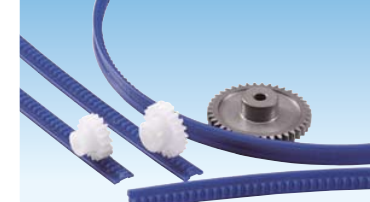



Gears used to drive intersecting axes

Gears to transmit the rotary motion and power between two intersecting shafts.

★ SMSG Ground Spiral Miter Gear



★ SUM Stainless Steel Miter Gear



★ SMA Finished Bore Miter Gear



★ MBSG Ground Spiral Bevel Gear



★ PB Plastic Bevel Gear

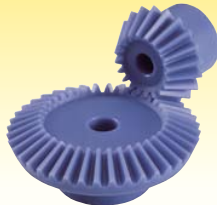

★ SB Bevel Gear & Pinion Shaft

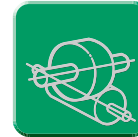

Gears used to drive nonparallel, nonintersecting axes

Gears to transmit the rotary motion and power between two nonparallel and nonintersecting shafts.

★ SN Steel Screw Gear



★ SUN Stainless Steel Screw Gear



★ PN Plastic Screw Gear



★ KWG • AGF Ground Worm Shaft, Worm Wheel



★ KWGDL • AGDL Duplex Worm, Worm Wheel



★ SUW • PG Worm, Plastic Worm Wheel



7. Fundamental Gear terms

Module? Reference diameter? - What do they mean?

Cited here are technical terms used with reference to gears. Though these terms are used on an infrequent basis, the knowledge of these terms will help you better understanding gears.

■ Technical terms for gears

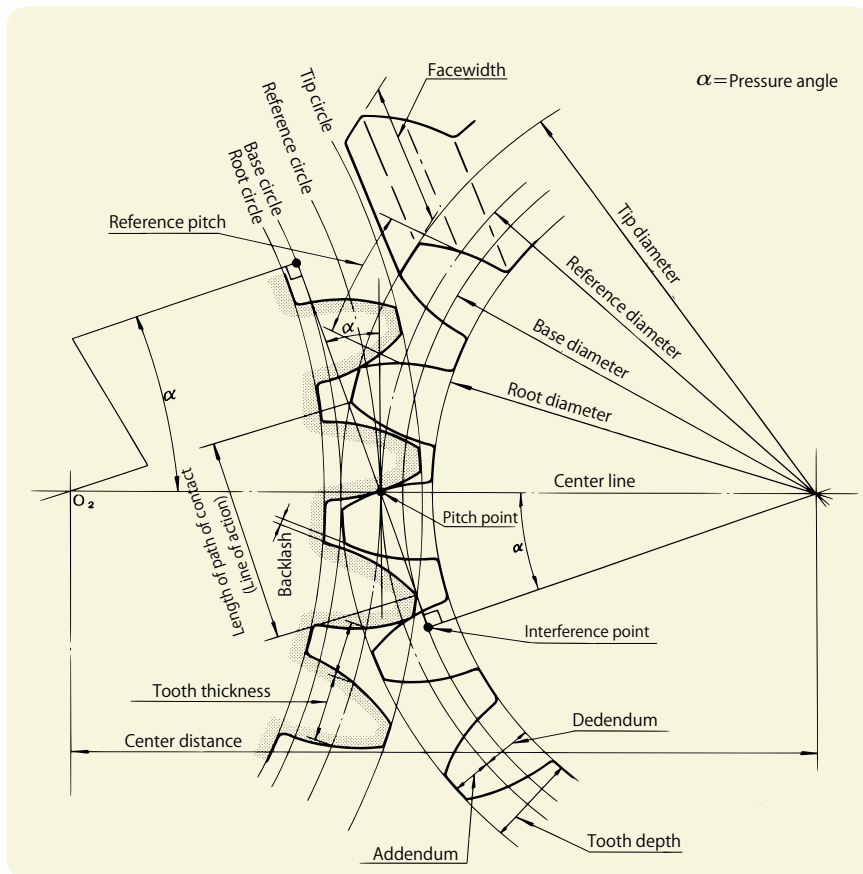

■ Comparative Size of Gear-Tooth

m 1, m 3, m 8, . . .

The " m " represents "module" and the system of unit used is the metric system. These m 1, m 3, m 8 are called Module One, Module Three, Module Eight, respectively. This is the global vocabulary to express the size of gear-tooth. The bigger the number, the larger the tooth size.

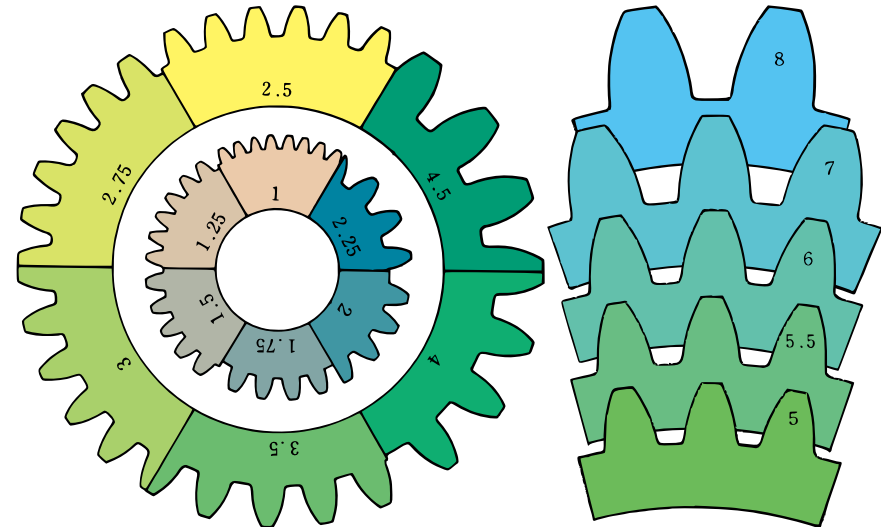

In the United States and other countries where the unit of length in common use is "inch", "Diametral pitch" is widely used to represent the tooth size. For example, DP24, DP8, (DP - the ratio of the number of teeth to the diameter of the pitch circle measured in inches.)

"Circular pitch" is also used to represent the tooth size. In that case, the sizes of tooth are designated as CP5, CP10

■ Tooth profile and pressure angle

Involute gear teeth and cycloidal gear teeth are typical of the tooth profile. Modern gearing is based on involute teeth. Satisfactory gears must transmit power and motion smoothly by rolling action. The involute gear form provides constant velocity ratios between mating gear teeth.

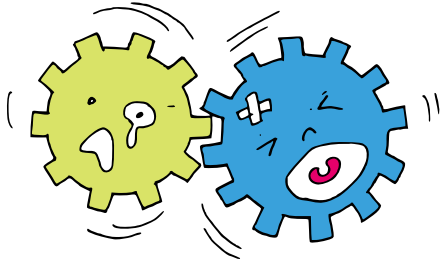

[Features of the involute teeth]



- Conjugate action is relatively independent of small errors in center distance.
- Can be manufactured at low cost since the tooth profile is relatively simple.
- Allow the contact point to move smoothly, transmitting the motion.
- Can save time and labor to change hobs since a single hob can process gears of different numbers of teeth if the size (module) of teeth is the same.
- The teeth are strong because of their root thickness.

The pressure angle will be dealt with in the subsequent course, but it is usually 20°. In some cases, however, it is 14.5°, 15° or 17.5°, 22.5°, or 27°.

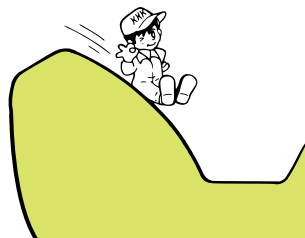

■ Direction of hand, and mating

A pair of helical gears connecting parallel shafts is made up of opposite hand gears, that is, one will be a left-hand gear; the other a right-hand gear. The same applies to spiral bevel gears. As for screw and worm gears connecting non-parallel shafts, if the shaft angle is 90 degrees, the gears will be of the same hand. The teeth of a left-hand gear lean to the left and the teeth of a right-hand gear lean to the right when the gear is placed on a flat surface.

● Helical gear

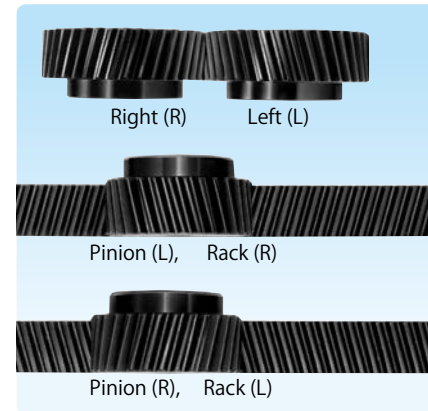

● Spiral bevel gear

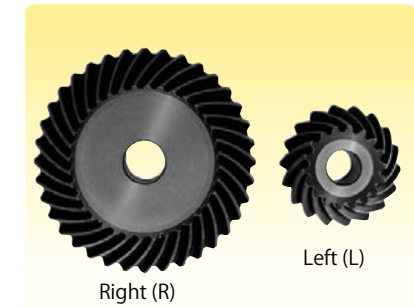

● Screw gear

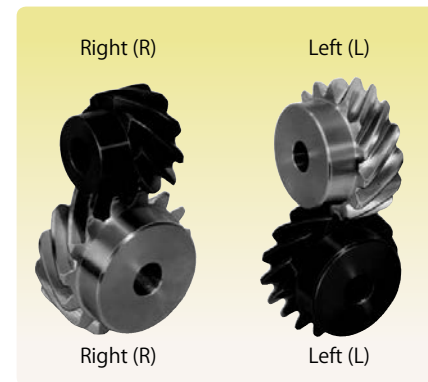

● Worm gear pair

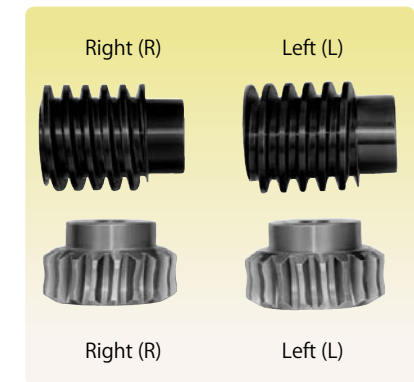

8. Gear Materials and Heat Treatment

Let's see what sort of materials are used to produce gears, and why?

Choosing the proper material is vitally important. As the applications of gears are so diverse, various materials are used. Dealt with here are gear materials and heat treatment.

■ Gear materials and their features.

● Ferrous metals

S45C (Carbon steel for machine structural use), and SCM415 (Case-hardening alloy steel) are most commonly used in Japan. Both are good materials for making gears.

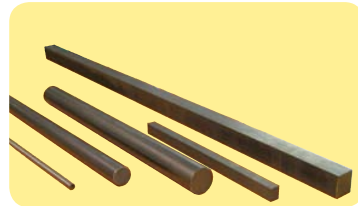

Steel round and rectangular bars

● Nonferrous metals

Aluminium bronze castings are wear-resistant. The gears made out of these nonferrous metals are used for worm wheels and screw gears, etc. because of their wear-resistance. As they are castings, they are somewhat costly and their procurement is more difficult.



Aluminum bronze casting
(The core portion - grey iron casting)

● Plastics

Plastics are used as the gear material for the applications that require the operation with minimum or no lubrication, such as food processing machines and toys, etc. Plastic gears made by the injection molding process are very cost effective and are used in such applications as light duty office machines etc.



Plastic round bars

■ Heat treatment

Steels get stable in their structure when heat treated and become harder and stronger. The illustration here depicts forge scenes of a Japanese blade KATANA.



● Thermal Refining

This is the heat treatment to refine crystal structure of steels to improve the strength.

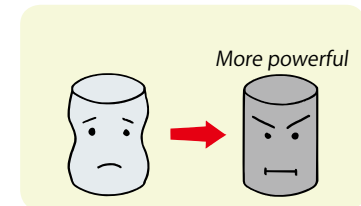

● High-Frequency Induction Hardening

This is the process where steels are hardened by means of induction heating (approx.800°C) and subsequent quenching.

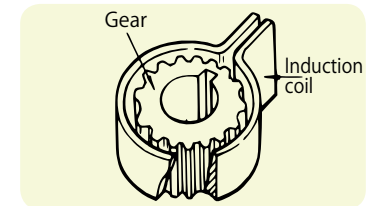

● Carburizing and Quenching

After diffusing carbon molecules into the surface of steel at high temperature, steels are case hardened to produce a hard and wear-resistant surface with progressively softer core which retains ductility.

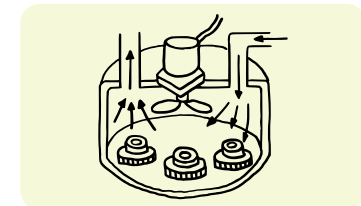

9. Gear Accuracy and Strength

No wonder gears with high precision are durable and quiet.

Now, let's think about gear accuracy and strength. Good gears are considered to be:

- ① Small and light
- ② Able to transmit high power and forces
- ③ Quiet
- ④ Durable

Strength and durability

The strength of gears is expressed in terms of bending strength and surface durability. If the force beyond the limits is put on the teeth,

- the teeth will be broken, or
- the surface of the teeth will be worn.

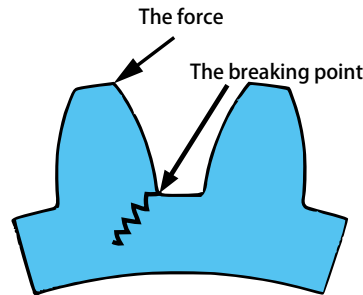

In making gears it is important to establish tolerance requirements appropriate for the application. So if gears with much higher strength are required, a suitable material must be chosen, and, if necessary, the material must be hardened. Also, the gears must be produced with higher accuracy. The material to be used and the accuracy are very important factors contributing to gear strength and quietness.

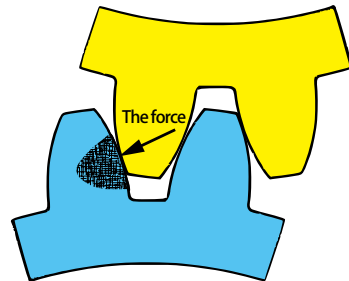

Accuracy

Quality gears must transmit power smoothly, with a minimum of vibration and noise. To make gears as quiet as possible, it is necessary that:

① the tooth profile is correct involute form.	
② the tooth trace (flank line) is accurate.	
③ the tooth contact is good.	
④ the pitch error is reduced to minimum.	
⑤ the runout error is reduced to minimum, and gears are concentric.	

10. How to Make Gears

Let's get familiar with the way gears are made. Are you with me?

■ Gear cutting of helical gears with gear hobs

Gear hobs are shaped like a screw. This photo shows that the teeth of a helical gear are being generated with the hobbing machine when the gear blank and the gear hob are meshed. In this same manner the gear cutting of spur gears and worm wheels is carried out.

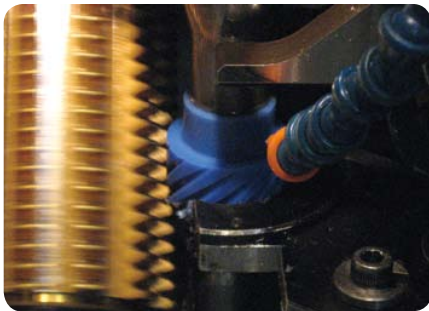

Gear hob

■ Gear cutting of racks with rack cutters

This photo shows that the gear cutting of racks is in progress with the rack cutter. Many teeth are cut at a time. Rack cutters, in the same way, handle gear cutting of helical racks.

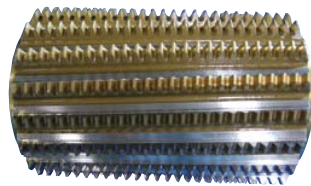

Rack cutter

■ Gear cutting of spur gears with pinion type cutters

Pinion type cutters are shaped like a spur gear. These photos here show that the pinion type cutters are in operation. The pinion type cutters can also cut gear teeth of internal gears.

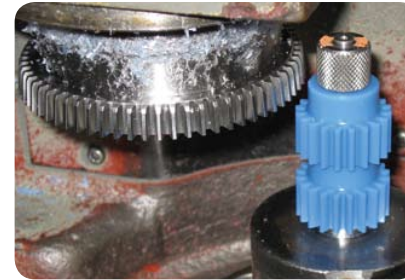

Pinion type cutter

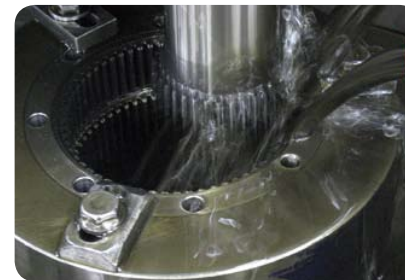

■ Gear cutting of worms with worm cutters

This photo shows that gear teeth of a worm are being generated with the worm cutter. The gear cutting is rather time-consuming. Worm cutters are common to milling cutters.



Worm cutter

■ Gear cutting of straight bevel gears with Coniflex cutters

The gear cutting is being done with a set (the upper cutter and the lower cutter) of Coniflex cutters. Coniflex cutters produce gear teeth of accurate tooth contact. So the gears made with Coniflex cutters operate quietly.

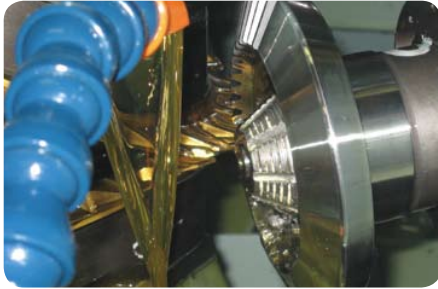

Coniflex cutter (the lower cutter)

■ Gear cutting of spiral bevel gears with spiral bevel cutters

The gear teeth of a right-hand spiral bevel gear is being generated. Spiral bevel cutters are shaped like a crown.



Spiral bevel cutter

■ The grinding of helical gears with threaded grinding wheels

The gear teeth of a helical gear are being ground with a threaded grinding wheel. The grinding efficiencies are good because of its multiple threads. Spur gears can be ground in the same way with the threaded grinding wheels.

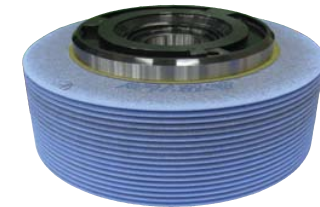
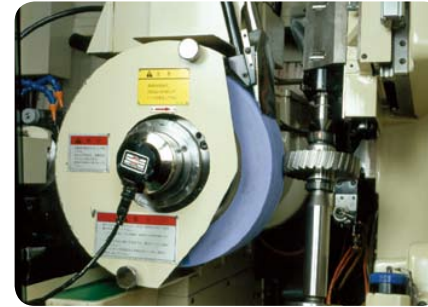

Threaded grinding wheel

■ The grinding of worms with single-rib grinding wheels

A single-rib grinding wheel, rotating at a very high speed, is smoothing the gear teeth of a worm to increase their accuracy.

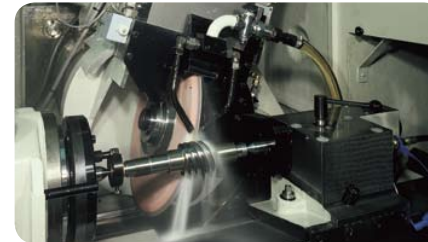

Single-rib grinding wheel

■ The grinding of racks with single-rib grinding wheel

The grinding of a rack is being carried out in the room where temperature is kept at 20°C. Grinding wheels are shaped like a discus. The grinding of high quality racks requires a special technique and know-how.



Single-rib grinding wheel

Injection Molding

Heated plastic is forced under pressure into a mold cavity. The heated plastic is then clamped together and solidifies into the shape of the mold, or the shape of the gear. Injection molding is suited for mass production, not for a small quantity because of high cost of mold. KHK's products: DS Injection Molded Spur Gears and DM Injection Molded Miter Gears

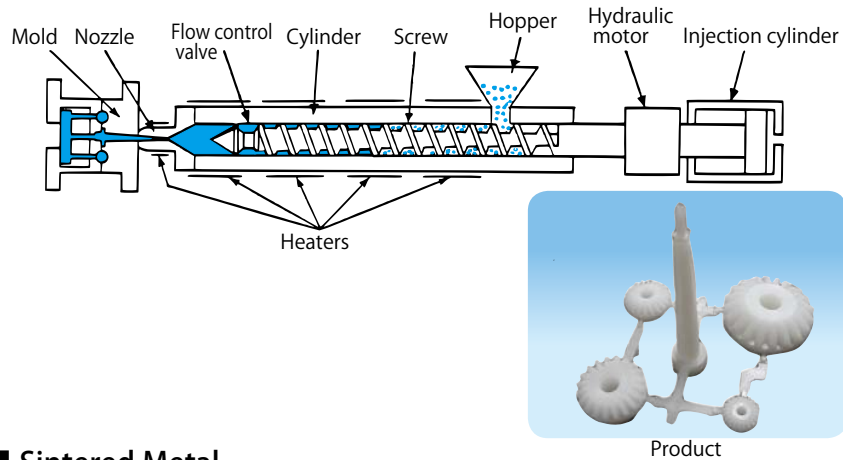

Sintered Metal

The mixed powdered metal is compressed by machine to form the gear shape. Then it is heated in a furnace and bonded metallurgically. This method is cost-effective when mass-produced. KHK's products: LS Sintered Metal Spur Gears and LM Sintered Metal Miter Gears.

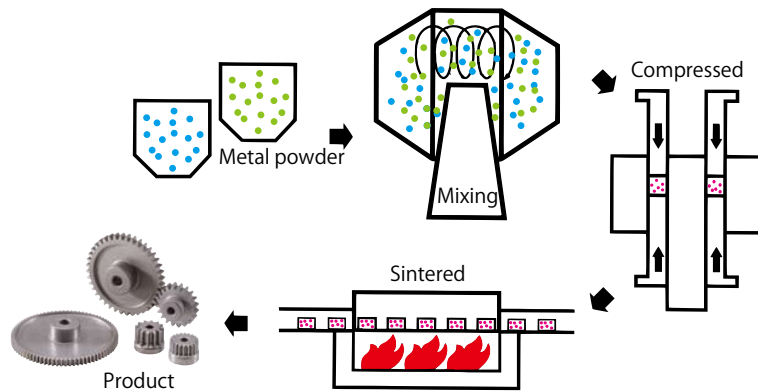

Roll Threading

A round steel bar is threaded between grooved circular rolls by rolling. Thus smooth gear teeth are formed. KHK's products: SW Worms (Module 2 or smaller size)

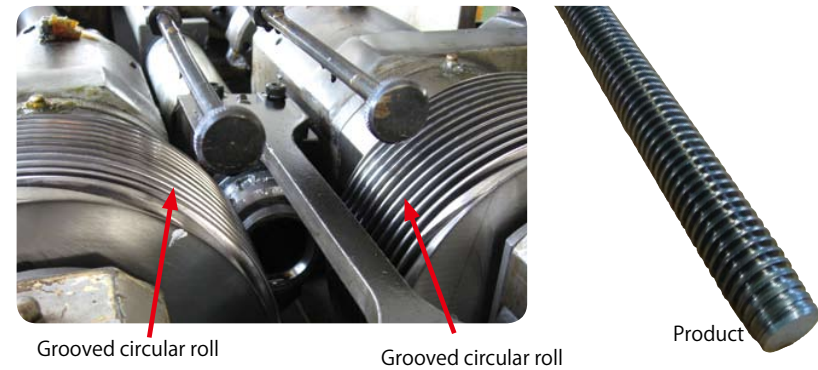

Press

Pressure is applied to a workpiece by the press, by which a material is cut or shaped under pressure. KHK stock gears are not made by this method. KHK's products: Rack Clamps for DR Molded Flexible Racks

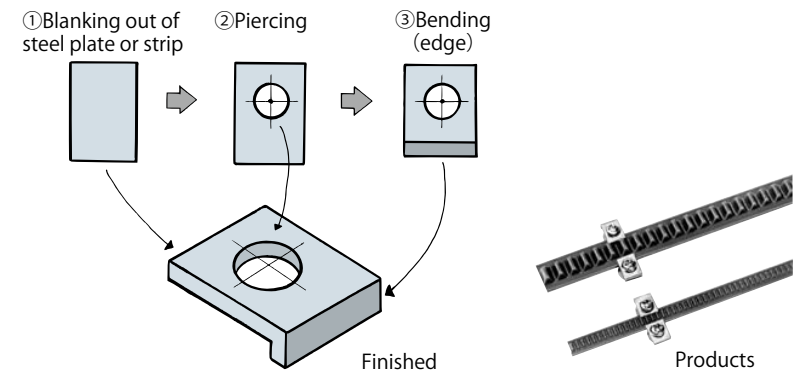

11. Gears Are Ubiquitous

Yes, if I may be allowed a little exaggeration.

Look around yourself and you'll find gears are used everywhere. Isn't that surprising?

■ Pencil sharpener

An internal gear and a spur gear are used. The spur gear turns the cutter mounted to the shaft to sharpen pencils.



An internal gear and a spur gear to turn a cutter

■ Clock

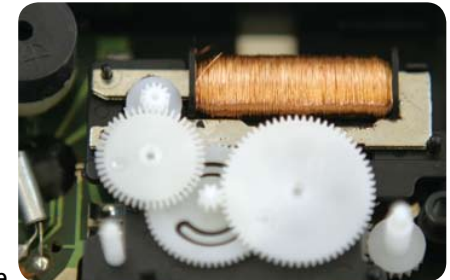

Various spur gears are used to move the hands.

Gears to turn the minute hand, the hour hand, and the second hand.

■ Paperpunch

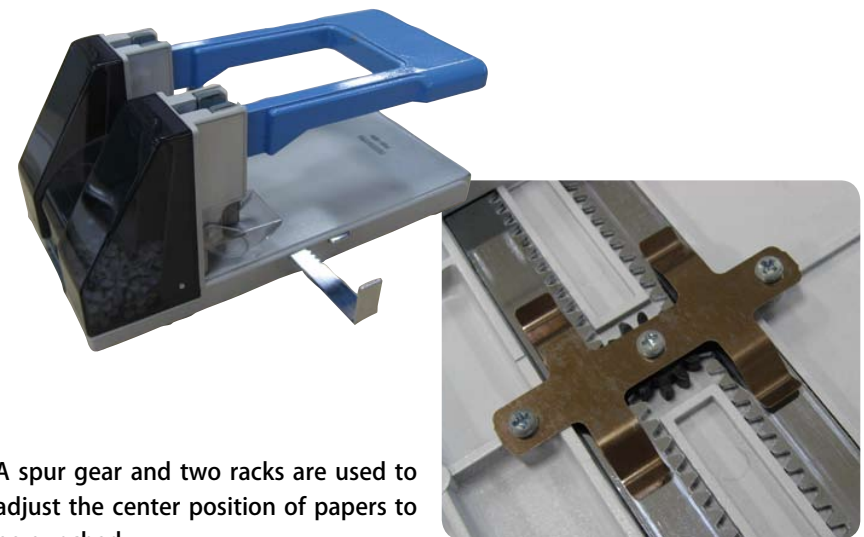

A spur gear and two racks are used to adjust the center position of papers to be punched.

A spur gear between racks

Flashlight



A three-stage gear train is used to turn a dynamotor on. Spur gears are used here.

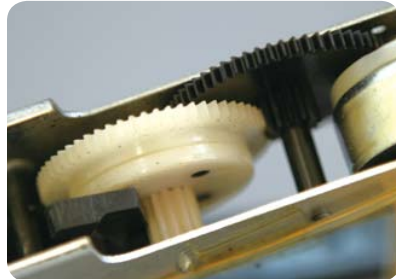

4 pieces of multiplying gears (white and black)

Tripod



A round rack and a pinion

A round rack gives an up-and-down motion by the turning of a handle. Pan/tilt head is fixed at the top of the rack. Taking the tripod apart you will see a pinion mated with a rack.

Ice cream scoop



By pressing the lever, the ice cream in the scoop is released into the dish; the gears attached to the lever turn the blade in the scoop which releases the ice cream.

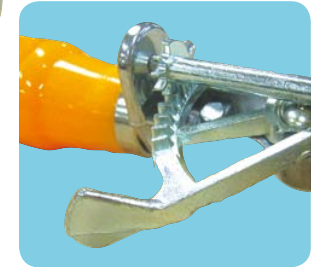

A set of gears

Music box



When you turn the crank, the worm starts to move and turns the worm wheel. The worm wheel, then, turns the musical drum, and the musical drum plays a tune.



A musical movement (a worm gear pair is seen above.)



KOHARA GEAR INDUSTRY CO., LTD.

Head office/factory 〒 332-0022 13-17 Nakacho, Kawaguchi-shi Tel:048(255)4871 FAX:048(256)2269

Osaka office 〒 540-0012 Tanimachi Yuetsukan building,6-22 Tanimachi 5-chome, Chuo-ku, Osaka
TEL:06-6763-0641 FAX:06-6764-7445

Nagoya office 〒 465-0093 Louvre Building, 3-96 Issha, Meito-ku, Nagoya
TEL:052-704-1681 FAX:052-704-1803

URL <http://www.khkgears.co.jp/> E-mail kohara@khkgears.co.jp

- All rights reserved. No part of this work covered by the copyright hereon may be reproduced or used in any form or by any means.
- This publication is designed to provide information on gears with gear users as well as employees of KHK group companies.
- KOHARA GEAR INDUSTRY CO., LTD. disclaim responsibility for any error or omission regarding technical and product information published.
- The contents of this publication are subject to change without notice.

KHK The ABCs of Gears

A - The Introductory course

January 5, 2007 First edition

Written by : KOHARA GEAR INDUSTRY CO, LTD

Publisher KOHARA GEAR INDUSTRY CO., LTD.

13-17 Naka-cho, Kawaguchi-shi, Saitama-ken, 332-0022 Japan

Editorial supervisor: Masahiro Fujii, Japanese Patent Attorney

Gotoh & Partners

