

















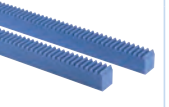





# Racks

<b>MRGF/MRGFD</b> Hardened Ground Racks  Material: SCM415 m1.5-3 Page 224	<b>KRGF-H/KRGFD-H</b> Hardened Ground Racks  Material: SCM440 m1.5-3 Page 226	<b>KRG/KRGF/KRGFD</b> Thermal Refined Ground Racks  Material: SCM440 m1-3 Page 228	<b>SRG/SRGF/SRGGFD/SRGGK</b> Hardened Ground Racks  Material: S45C m0.5-6 Page 230	<b>KRF-H/KRFD-H</b> Hardened Racks  Material: SCM440 m1.5-5 Page 232	<b>SRF-H/SRFD-H</b> Hardened Racks  Material: S45C m1.5-6 Page 234	<b>SRF-HL/SRFD-HL</b> Laser Hardened Racks  Material: S45C m1.5-6 Page 236	<b>SRAF-HL/SRAFD-HL/SRAFK-HL</b> Laser Hardened Square Racks  Material: S45C m1.5-4 Page 238
<b>KRF/KRFD</b> Thermal Refined Racks  Material: SCM440 m1.5-5 Page 240	<b>SRAF/SRAFD/SRAFK</b> Square Racks  Material: S45C m1.5-4 Page 242	<b>SR</b> Racks  Material: S45C m0.5-10 Page 244	<b>SRF</b> Steel Racks with Machined Ends  Material: S45C m0.5-10 Page 245	<b>SRFD/SRFK</b> Steel Racks with Bolt Holes  Material: S45C m0.5-6 Page 246	<b>SUR/SURF/SURFD</b> Stainless Steel Racks  Material: SUS304 m1-4 Page 248	<b>DRF/DRFD/DRFK</b> Plastic Racks  Material: Polyacetal m1-3 Page 250	<b>PR/PRF</b> Plastic Racks  Material: MC901 m1-3 Page 252
<b>BSR</b> Racks  Material: Free cutting brass (C3604) m0.5-1 Page 253	<b>SRO/SROS</b> Round Racks  Material: S45C m1-5 Page 254	<b>SURO</b> Stainless Steel Round Racks  Material: SUS303 m1-3 Page 255	<b>DR</b> Molded Flexible Racks  Material: Duracon (P) (M25-44) m0.8-2 Page 256	<b>SSDR/ARL/SRS</b> Rack Clamps for Pinions/Rack Guide Rails For Molded Flexible Racks  Material: S45C, etc. Page 256	<b>KRHG/KRHGF/KRHGFD</b> Ground Helical Racks  Material: SCM440 m1-3 Page 258	<b>SRHEF-HL</b> Laser Hardened Helical Racks  Material: S45C m3-6 Page 260	<b>SRH/SRHF/SRHFD</b> Helical Racks  Material: S45C m2, 3 Page 262
<b>SRHEF</b> Helical Racks  Material: S45C m1.5-6 Page 264	<b>SHE-H</b> Hardened Helical Gears  Material: S45C m1.5-6 Page 264	<b>SHE</b> Helical Gears  Material: S45C m1.5-6 Page 264	<b>ZST/ZSTD</b> Hardened Ground Helical Racks  Material: DIN C45 (S45C equivalent) m2-6 Page 266	<b>ZSTP</b> Ground Helical Gears  Material: SCM440 m2-6 Page 266	<b>ZST-GL</b> Assembly Gauges  Material: S45C m1.5-6 Page 268		

**M** Includes Made to Order

## Catalog Number of KHK Stock Gears

The Catalog Number for KHK stock gears is based on the simple formula listed below. Please order KHK gears by specifying the Catalog Numbers.

(Example) Racks

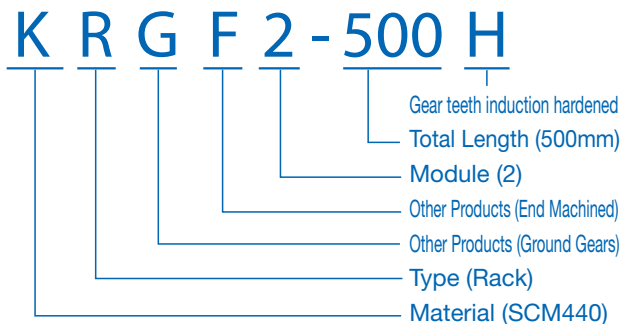

### Material

M	SCM415
K	SCM440
S	S45C
SU	Stainless Steel
BS	Brass
P	MC901
D	Polyacetal

### Type

R	Racks
RH	Helical Racks
RO	Round Racks
S	Spur Gears
H	Helical Gears

### Other Information

F	Racks with Machined Ends
D	Racks with Bolt Holes
K	Racks with Drill Holes
G	Ground Gears
H	Gear teeth induction hardened
HL	Laser hardened
ZST	Manufactured by Schneebeger

Spur Gears

Helical Gears

Internal Gears

Racks

CP Racks & Pinions

Miter Gears

Bevel Gears

Screw Gears

Worm Gears

Gearboxes

Other Products

## Features



KHK stock racks are made for high precision linear motion applications. We offer a large selection of racks ranging from module 0.5 to 10 and lengths up to 2000 mm. The following table lists the main features.

### Racks

Catalog Number <small>Note 1</small>	Module	Total Length mm Parentheses show no. of teeth	Material	Heat Treatment	Tooth Surface Finish	Gear accuracy <small>KHK R 001 Note 3</small> Parentheses show <small>JIS B 1702-1</small>	Features
<b>MRGF/MRGFD</b>	1.5~3	500	SCM415	Carburized	Ground	1	Racks that have been carburized and ground that have excellent accuracy, strength and wear resistance. Secondary operations are possible except for tooth and both ends.
<b>KRGF-H KRGFD-H</b>	1.5~3	500, 1000	SCM440	Thermal refined, gear teeth induction hardened	Ground	1	Racks that have been tempered, hardened and ground that have excellent accuracy, strength and wear resistance. Secondary operations are possible except for tooth.
<b>KRG/KRGF/ KRGFD</b>	1~3	100, 500, 1000	SCM440	Thermal refined	Ground	1	Racks that have been tempered and ground that have excellent accuracy and strength.
<b>SRG/SRGF SRGFD/SRGFK</b>	0.5~6	100, 300, 500, 1000	S45C	Gear teeth induction hardened <small>NOTE 2</small>	Ground	3	Racks that have been hardened and ground with a good balance of accuracy, wear resistance and cost. Secondary operations are possible except for tooth.
<b>KRF-H/KRFD-H</b>	1.5~5	1000	SCM440	Thermal refined, gear teeth induction hardened	Cut	5	Racks that have been tempered and hardened that have excellent strength and wear resistance. Secondary operations are possible except for tooth.
<b>SRF-H SRFD-H</b>	1.5~6	1000	S45C	Gear teeth induction hardened	Cut	5	Racks that have been hardened with excellent wear resistance. Secondary operations are possible except for tooth.
<b>SRF-HL SRFD-HL</b>	1.5~6	1000, 1500, 2000	S45C	Gear teeth laser hardened	Cut	4	Racks that have been laser hardened with a good balance of wear resistance and cost. Secondary operations are possible except for tooth.
<b>SRAF-HL/ SRAFD-HL SRAFK-HL</b>	1.5~4	1000	S45C	Gear teeth laser hardened	Cut	4	Racks that have been laser hardened with a good balance of wear resistance and cost. These racks have smaller tooth height and save space in comparison to SRF-HL Racks.
<b>KRF/KRFD</b>	1.5~5	500, 1000	SCM440	Thermal refined	Cut	4	Racks that have been tempered with excellent strength.
<b>SRAF/SRAFD SRAFK</b>	1.5~4	1000, 2000	S45C	—	Cut	4	These racks have smaller tooth height in comparison to SRF Racks.
<b>SR/SRF SRFD/SRFK</b>	0.5~10	100, 300, 500, 1000, 1500, 2000	S45C	—	Cut	4	Many lineups are available at a low price and excellent usability.
<b>SUR/SURF SURFD</b>	1~4	500, 1000	SUS304	Solution treated	Cut	5	Stainless steel racks with rust resistance.
<b>DRF/DRFD DRFK</b>	1~3	500, 1000	Polyacetal	—	Cut	5	Racks made of polyacetal with shorter overall length than nylon, making them suitable for joining together.
<b>PR/PRF</b>	1~3	500, 1000	MC901	—	Cut	5	Nylon racks can be used with no lubrication.
<b>BSR</b>	0.5~1	300	Free-cutting Brass (C3604)	—	Cut	4	Brass racks with excellent machinability.
<b>SRO/SROS</b>	1~5	500, 1000	S45C	—	Cut	4	Round racks that are suitable when the rack side moves.
<b>SURO</b>	1~3	500, 1000	SUS303	—	Cut	5	Round racks made of stainless steel. Suitable when the rack side moves.
<b>DR</b>	0.8~2	2000	Duracon (R) (M25-44) <small>NOTE 4</small>	—	Injection Molded	8	Thin plastic racks that can be bent.
<b>KRHG/KRHGF KRHGF</b>	1~3	100, 500, 1000	SCM440	Thermal refined	Ground	1	Helical racks that have been tempered and ground with excellent accuracy that have higher strength and quietness as compared with KRGF.
<b>SRHEF-HL</b>	3~6	1000	S45C	Gear teeth laser hardened	Cut	4	Helical racks that have been laser hardened that have excellent strength and wear resistance in comparison to SRHEF Racks. They can be used like CP racks.
<b>SRH/SRHF SRHFD</b>	2~3	100, 1000	S45C	—	Cut	5	As they are helical racks, they have higher strength and quietness as compared with SRF.
<b>SRHEF</b>	1.5~6	1000	S45C	—	Cut	4	As they are helical racks, they have higher strength and quietness as compared with SRF. They can be used like CP racks.
<b>ZST/ZSTD</b>	2~6	1000, 2000	DIN C45 (JIS Grade S45C equivalent)	Gear teeth induction hardened	Ground	Grade 2 equivalent	Helical racks that have been hardened and ground that have excellent accuracy, wear resistance and quietness. They can be used like CP racks. Secondary operations are possible except for tooth.

### Pinion

<b>SHE</b>	1.5~6	(18~30)	S45C	—	Cut	(N8)	SRHEF pinions that have excellent strength and quietness as compared with SS due to its helix.
<b>ZSTP</b>	2~6	(18~30)	SCM440	Thermal refined, gear teeth induction hardened	Ground	(N6)	ZST pinions with high accuracy that have excellent strength, wear resistance and quietness due to its helix. Secondary operations are possible except for tooth.

[NOTE 1] The catalog numbers of the above racks with (F) suffix have both ends machined so that they can be butted against each other. The items with (D) have mounting screw holes for immediate assembly.

[NOTE 2] Products with module under 1 are thermal refined, without their gear teeth being induction hardened.

[NOTE 3] Precision grade standard of racks are set by KHK. Please see "Precision of Racks" in Selection Hints section for details.

[NOTE 4] "Duracon (R)" is a registered trademark of Polyplastics Co., Ltd. in Japan as well as other countries.

● KHK stock racks have round semi-topping at the corners of the top land of the gear tooth.

● Black products are KHK stock gears that have an applied black oxide coating for rust resistance.

## Application Examples



Racks & pinions are adopted in driving devices for linear motion systems, such as transport devices.

### ■ Circular saw cutting machine HS-400 manufactured by Kooki Co., Ltd.



SRFD racks and SSG spur gears used for automatic and manual drive for cutting, machining of both ends and deburring

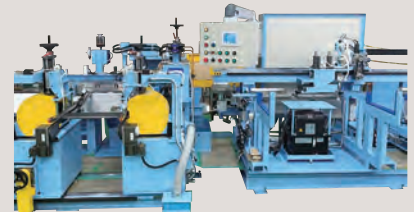

### ■ Clamp Seamer Welder

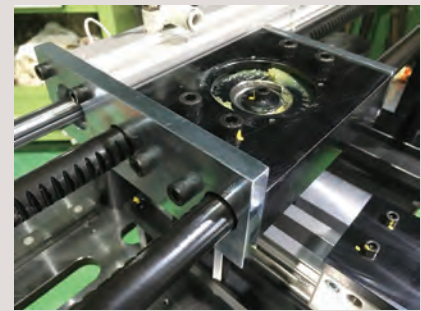
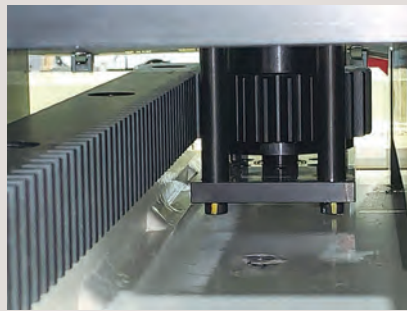

The SRCPFD racks and SSCP spur gears used to drive weld torches at constant speed, and the SRO round racks and SS spur gears used to position workpieces

### ■ Dremax Long Strip Cutter



PR plastic rack used for feeding Long Strip Cutter



### ■ Lathe Auto Loader



SRO Round Rack used as a workpiece storage device (lifting/lowering table)

### ■ Lathe Gantry Loader

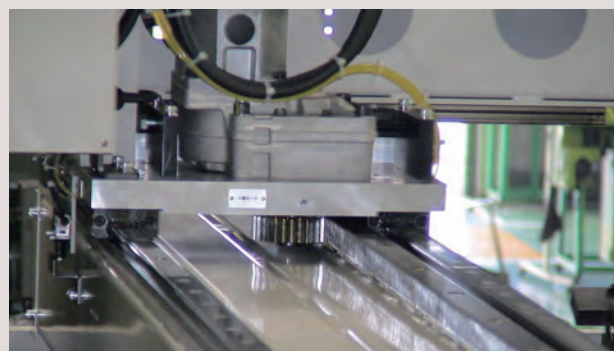

KRG Ground Rack used as a workpiece conveying device

## Selection Hints



Please select the most suitable products by carefully considering the characteristics of items and contents of the product tables. It is also important to read all applicable "CAUTION" notes shown below before the final selection.

### 1. Caution in Selecting the Mating Gears

- With the exception of helical racks, KHK stock racks can mate with any spur gears of the same module. Products with different tooth width can also be mated as a pinion.
- See the table on the right for the mating gears of the helical racks.  
Be sure to check the combination of helix direction (right or left) when selecting.

### 2. Caution in Selecting Gears Based on Gear Strength

The gear strength values shown in the product pages were computed by assuming the application environment in the table below. Therefore, they should be used as reference only. We recommend that each user computes their own values by applying the actual usage conditions.

### Calculation of Bending Strength of Gears

Item	Racks										Pinion				Racks		
	MRGF	KRGF-H	KRG/KRGF	SRG/SRGF	SRF-HL	SRAF/SRAFD	SUR	BSR	SHE	SHE-H	ZSTP	DRF	PR	DR			
Catalog Number	MRGFD	KRGFD-H	KRGFD	SRGFD/SRGFK	SRFD-HL	SRAFK/SR/SRF	SURF				DRFD	PRF					
	KRF-H	KRHG/KRHGF	KRHG/KRHGF	SRF-H/SRFD-H	SRAF-HL	SRAF/SRF/SRO	SURFD				DRFK						
	KRFD-H	KRHGFD/KRF	KRFD	ZST/ZSTD	SRAF-HL	SROS/SRH/SRHF	SURO										
Formula <small>NOTE 1</small>	Formula of spur and helical gears on bending strength (JGMA401-01)										The Lewis formula						
No. of teeth of mating gears	30 <small>NOTE 2</small>										(30)						
Rotational Speed of Pinion	100rpm										(100rpm)						
Design Life (Durability)	Over 10 <sup>7</sup> cycles										Allowable bending stress (kgf/mm <sup>2</sup> )						
Impact from motor	Uniform load																
Impact from load	Uniform load																
Direction of load	Bidirectional load (calculated with allowable bending stress of 2/3)																
Allowable bending stress at root $\sigma_{Fim}$ (kgf/mm <sup>2</sup> )	47	30	29.5	20 <small>NOTE 3</small>			10.5	4	19	19	30	1.0 (40°C with No Lubrication)	1.15 (40°C with No Lubrication)	<i>m</i> 0.8 4.0 <i>m</i> 1.0 3.5 <i>m</i> 1.5 1.8 <small>NOTE 4</small> <i>m</i> 2.0 1.2 (40°C with Grease Lubrication)			
Safety factor $S_F$	1.2																

### Calculation of Surface Durability (Except where it is common with bending strength)

Formula <small>NOTE 1</small>	Formula of spur and helical gears on surface durability (JGMA402-01)													
Kinematic viscosity of lubricant	100cSt(50°C)													
Gear support	Supported on one end.													
Allowable Hertz stress $\sigma_{Hlim}$ (kgf/mm <sup>2</sup> )	166	112	76	90 <small>NOTE 3</small>	80	52.5	41.3	-	49	90	112			
Safety factor $S_H$	1.15													

**[NOTE 1]** The gear strength formula is based on JGMA (Japanese Gear Manufacturers Association) specifications, "MC Nylon Technical Data" by Mitsubishi Chemical Advanced Materials and "Duracon (R) Gear" by Polyplastics Co. The units for the rotational speed (rpm) and the stress (kgf/mm<sup>2</sup>) are adjusted to the units needed in the formula.

**[NOTE 2]** No. of mating teeth in the ZST and ZSTD racks is the "minimum number of teeth" of the ZSTP pinion. The No. of mating teeth in the SRHEF racks is also calculated by the "minimum number of teeth" of the SHE pinion.

**[NOTE 3]** For SRG, or SRGF Ground Racks, with a module less than *m*0.8, the allowable bending stress and allowable hertz stress are respectively 24.5 (kgf/mm<sup>2</sup>) and 62.5 (kgf/mm<sup>2</sup>).

**[NOTE 4]** The values for DR *m* 1.5 racks were assumed by KHK. Usage conditions for SDR (DR Rack Pinion) are the same for the SSCP Pinion, shown on Page 273.

### Mating Helical Gear Selection Chart (○ Allowable X Not allowable)

Catalog Number and Direction of Helix		KRHG KRHGF		ZST ZSTD		SRHEF		SRH/SRHF SRHFD	
		RH	LH	RH	RH	RH	LH		
KHG	LH	○	X	X	X	X	X	X	X
	RH	X	○	X	X	X	X	X	X
ZSTP	LH	X	X	○	○	X	X	X	X
SHE	LH	X	X	○	○	X	X	X	X
SH	LH	X	X	X	X	○	○	X	X
	RH	X	X	X	X	X	X	X	○



Pinion (L) & Rack (R)



Pinion (R) & Rack (L)

When selecting KHK standard gears, glance over the Product Precautions on Page 218 and Cautions on Performing Secondary Operations on each page.

- Products not listed in this catalog or materials, modules, number of teeth and the like not listed in the dimensional tables can be manufactured as custom items. Please see Page 26 for more details about custom-made orders.
- The color and shape of the product images listed on the dimension table page of each product may differ from the actual product. Be sure to confirm the shape in the dimension table before selection.
- The details (specifications, dimensions, etc.) listed in the catalog may be changed without prior notice. Changes are announced on the KHK website.

Website

URL: <https://khkgears.net/new/>

Overseas Sales Department: Phone: +81-48-254-1744 Fax: +81-48-254-1765 E-mail: [info@khkgears.net](mailto:info@khkgears.net)

# Selecting the Gears

## Step 1

Determine the calculated load torque applied to the gear and the gear type suitable for the purpose.

## Step 2

Select provisionally from the allowable torque table in this catalog based on the load torque.

■ For provisional selection from this catalog

Catalog Number	Module	Effective number of teeth	Shape	Total Length				Allowable force (N)				Allowable force (kgf)			
				A	B	C	D	Bending strength	Surface durability	Bending strength	Surface durability				
KRG1-100	m1	29	R1	98	10	15	14	1410	585	144	59.7				
KRG1.5-100	m1.5	20		101	15	20	18.5	3180	1320	324	135				
KRG2-100	m2	14		98	20	25	23	5650	2350	576	240				
KRG2.5-100	m2.5	11		100	25	30	27.5	8830	3680	901	375				
KRG3-100	m3	9		101	30	35	32	12700	5310	1300	541				

Catalog Number	Module	No. of teeth	Shape	Total Length				Allowable force (N)				Allowable force (kgf)			
				A	B	C	D	Bending strength	Surface durability	Bending strength	Surface durability				
KRGF1-500	m1	159	RF	499.51	10	15	14	1410	585	144	59.7				
KRGF1-1000		318		999.03	10	15	14	3180	1320	324	135				
KRGF1.5-500	m1.5	106		499.51	15	20	18.5	3180	1320	324	135				
KRGF1.5-1000		212		999.03	15	20	18.5	6360	2640	648	270				
KRGF2-500	m2	80	502.65	20	25	23	5650	2350	576	240					
KRGF2-1000		160	1005.31	20	25	23	11300	4700	1152	480					
KRGF2.5-500	m2.5	64	502.65	25	30	27.5	8830	3680	901	375					
KRGF2.5-1000		128	1005.31	25	30	27.5	17660	7360	1802	750					
KRGF3-500	m3	53	499.51	30	35	32	12700	5310	1300	541					
KRGF3-1000		106	999.03	30	35	32	25400	10620	2600	1082					

Catalog Number	Module	No. of teeth	Shape	Total Length				Mounting hole dimensions				
				A	B	C	D	E	F	G	No. of holes	Size
KRGFD1-500J	m1	159	RD	499.51	10	15	14	6	24.76	150	4	M4
KRGFD1-1000J		318		999.03	10	15	14	6	49.51	180	4	M4
KRGFD1.5-500J	m1.5	106		499.51	15	20	18.5	8	24.76	150	4	M5
KRGFD1.5-1000J		212		999.03	15	20	18.5	8	49.51	180	4	M5
KRGFD2-500J	m2	80	502.65	20	25	23	10	26.33	150	4	M6	
KRGFD2-1000J		160	1005.31	20	25	23	10	52.66	180	4	M6	

## Step 3

Calculate the strength under the actual usage conditions.

Calculate the strength formally using the various gear strength formulas. Please see our separate technical reference book for more details. We recommend using the Website that allows the strength to be easily calculated.

■ Use the strength calculation function on our website.

### ■ Bending strength

Calculated values of the strength at which the gear teeth do not break due to fatigue.



Example of failure due to insufficient bending strength

### ■ Surface durability

Calculated values of the strength at which the gear teeth do not wear due to surface fatigue damage.



Example of wear due to insufficient surface durability



## Product Precautions



### Common Notes

#### [Caution on Product Characteristics]

- (1) The allowable forces shown in the table are calculated values according to the assumed usage conditions. Please see page 216 for more details.
- (2) The backlash values shown in the table are the theoretical values for the backlash in the circumferential direction of recommended pinions with the same pitch.
- (3) After attaching the racks to the base, fasten with dowel pins. Clamping only with mounting screws could possibly cause the screws to be broken, due to a heavy load.
- (4) See page 22 for more details on Hardened Plus (H Series and HJ Series).
  - KHK's Specifications for Heat Treatment
    - Hardened location: Tooth surface, or Tooth surface and Tooth root
    - Hardness: 50 to 60 HRC
  - \* Hardness and Depth of Gear-teeth Induction Hardening
    - The hardening method and the state of the hardened teeth area vary depending on the size of gears.
    - Since different hardening treatment is applied in accordance with the module and number of teeth, the hardness level is referred to as the hardness of the reference diameter.
    - For some of our products, the hardness at tooth tip / root may not be equal to the hardness you designated.
    - As to the effective case depth, it is specified by JIS, as "The distance from the surface of the case to the area with hardness HV450." The case depth differs from area to area of a tooth, so the depth cannot be specified.
    - Due to the gear teeth of racks and gears being induction hardened, no secondary operations can be performed on tooth areas including the bottom land (approx. 2 to 3 mm) and tooth areas at the end face of the rack (approx. 4 to 5 mm).
- (5) There is a decarburized layer (about 0.5 mm) on the block surface. The hardness of the decarburized layer does not increase even if it is quenched.

#### [J Series]

- (1) Number of pieces we can process for one order is 1 to 20 units. For larger orders, please request a price and delivery quote.
- (2) Black oxide is not re-applied to parts undergoing secondary operations.

### 3. Cautions on Selecting Racks By Precision

The precision standards of KHK stock racks are established by us.  
The table below indicates the tolerance ranges of our racks.

#### ① Pitch Errors of Racks (KHK R 001)

Our precision grades for pitch errors are established by referring to old JIS Standards. The precision grades are set from 1 to 8, in accordance with the tolerance of a single pitch error (S.P.E.), adjacent tooth-to-tooth error (T.T.E.), and the total composite error (T.C.E.) for each module and length.

#### ■ Precision Grades of Racks

Unit:  $\mu\text{m}$

Grade	Pitch Error	Over $m0.4$ to 1 CP2.5		Over $m1$ to 1.6 CP5		Over $m1.6$ to 2.5 -		Over $m2.5$ to 4 CP10		Over $m4$ to 6 CP15		Over $m6$ to 10 CP20	
		Rack Length (nominal)											
		1000 or less	1001 up to 2000	1000 or less	1001 up to 2000	1000 or less	1001 up to 2000	1000 or less	1001 up to 2000	1000 or less	1001 up to 2000	1000 or less	1001 up to 2000
1	S.P.E.	10	-	10	12	11	12	11	13	13	14	14	16
	T.C.E.	28	-	29	33	30	35	32	37	35	40	40	45
2	S.P.E.	14	-	14	17	15	17	16	18	18	20	20	23
	T.C.E.	39	-	41	48	43	49	46	53	50	57	58	64
3	S.P.E.	20	-	20	24	21	25	23	26	25	29	29	32
	T.C.E.	56	-	57	67	60	70	64	74	71	80	81	91
4	S.P.E.	28	-	29	33	30	35	32	37	35	40	40	45
	T.C.E.	79	-	81	95	85	99	91	105	100	115	115	130
5	S.P.E.	39	-	41	48	43	49	46	53	50	57	58	64
	T.C.E.	110	-	115	135	120	140	130	145	140	160	160	180
8	S.P.E.	206	206	212	212	219	219	-	-	-	-	-	-

[NOTE] ① Since the pitch accuracy of racks may vary due to humidity, the precision grades are evaluated at the bottom surface of the product, at the temperature of 20°C. The dimensions of the KHK PR Plastic Racks may vary widely due to humidity. Therefore, the total composite error is assumed to be excluded from this accuracy standard.

② For the accuracy of CP Rack, convert CP to  $m$  (module) when reference is made to the data in the table. ( $m = CP / \pi$ ).

#### ■ Comparison Table of Precision Grades of Racks

KHK R001	1	2	3	4	5	6	7	8
DIN 3962	Q5	Q6	Q7	Q8	Q9	Q10	Q11	Q12

\* Values in the table are guidelines only and not guaranteed values.

\* In the gray area, there are no equivalent products for stock gears.

#### ■ Pitch inspection and a sample report using Karl Zeiss ACCURA Coordinate Measuring Machine. (KHK R 001 Grade 1)

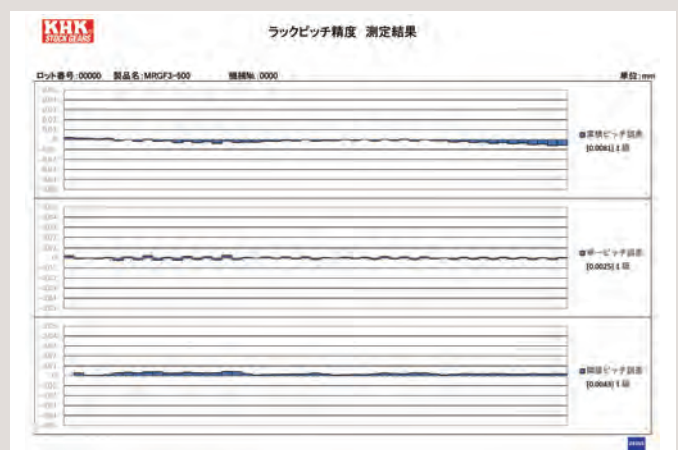

## ② Precision of Rack Blanks

### ■ Tolerances for Face Width and Height

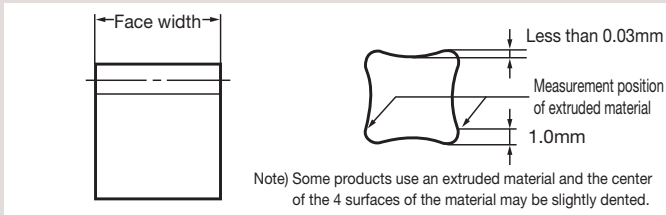

Unit: mm

Precision grade (KHK R 001)	Face width		
	Grade 1	Grade 2	Grades 3 to 5
8 or less	0 -0.05	0 -0.10	0 -0.22
9 to 10		0 -0.10	0 -0.27
11 to 18		0 -0.10	0 -0.33
19 to 30		0 -0.15	0 -0.39
31 to 50		0 -0.15	0 -0.46
51 to 90		0 -0.15	0 -0.46

[NOTE] Dimensional tolerance of hardened products is that prior to hardening. Dimensional tolerance for plastic racks is the value obtained when machining is performed, and may increase slightly due to aging.  
\* BSR products are not applicable.

### ■ Maximum Curvature Values (Flatness Tolerance L)

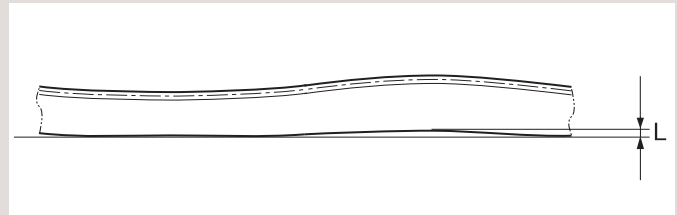

Unit: mm

Precision grade (KHK R 001)	Length (nominal)		
	Grade 1 & 2	Grade 3	Grade 4 & 5
500	0.05	0.1	0.2
1000	0.1	0.2	0.3
1500	—	—	0.3
2000	—	—	0.4

[NOTE] The straightness tolerances of round racks are 0.15/500 mm and 0.2/1000 mm. Plastic racks change over time so are excluded from this precision standard.

### ■ Tolerance on Total Length

Unit: mm

Product Type	Module	Dimensional Tolerance
F Type End Machined Product	m0.5	$\begin{pmatrix} -0.1 \\ -0.3 \end{pmatrix}$
	m0.8(CP2.5)	$\begin{pmatrix} -0.1 \\ -0.5 \end{pmatrix}$
	m1 up to 2.5	$\begin{pmatrix} -0.2 \\ -0.6 \end{pmatrix}$
	m2.5 or more	$\begin{pmatrix} -0.2 \\ -0.8 \end{pmatrix}$
FRCP and DR Flexible Racks	Uniform	$\pm 10$
Products other than the above	Uniform	$\begin{matrix} +3 \\ -2 \end{matrix}$

[NOTE] For Type-F racks with machined ends, the dimensional tolerance is a calculated value according to assumed usage conditions, without consideration of pitch errors and aged deterioration.

## ③ Backlash of Racks & Pinions

### ■ Backlash of Racks & Pinions (Circumferential)

Unit: mm

Module	CP	Precision Grade (KHK R 001)												
		Grade 1		Grade 2	Grade 3	Grade 4		Stainless Steel	Helical		Grade 5			
		Straight	Helical			Excludes thermal refined racks	Includes thermal refined racks		SRHF	SRHEF	Hardened	Thermal Refined + Hardened	MC nylon	* POM Excludes DR
m0.5	-	-	-	-	0.11 0.00	0.13 0.00	-	-	-	-	-	-	-	-
m0.8	CP2.5	-	-	-	0.12 0.00	0.14 0.00	-	-	-	-	-	-	-	-
m1	-	-	-	-	0.19 0.04	0.21 0.04	-	0.23 0.04	-	-	-	-	0.39 0.18	0.36 0.15
m1.5	CP5	0.14 0.04	0.15 0.05	0.14 0.04	0.19 0.04	0.25 0.09	0.27 0.09	0.27 0.09	-	0.28 0.10	0.29 0.05	0.31 0.05	0.42 0.21	0.39 0.18
m2	-	0.16 0.05	0.17 0.06	0.16 0.05	0.21 0.05	0.28 0.11	0.30 0.11	0.30 0.11	0.31 0.12	0.32 0.12	0.32 0.07	0.34 0.07	0.45 0.24	0.42 0.21
m2.5	-	0.16 0.05	0.17 0.06	0.16 0.05	0.21 0.05	0.31 0.13	0.33 0.13	0.33 0.13	-	0.35 0.14	0.35 0.09	0.37 0.09	0.49 0.26	0.46 0.23
m3	CP10	0.16 0.05	0.17 0.06	0.16 0.05	0.21 0.05	0.35 0.14	0.37 0.14	0.37 0.14	0.38 0.15	0.39 0.15	0.39 0.10	0.41 0.10	0.56 0.32	0.52 0.28
m4	-	-	-	0.16 0.05	0.21 0.05	0.42 0.18	0.44 0.18	0.44 0.18	-	0.47 0.19	0.46 0.14	0.48 0.14	-	-
m5	CP15	-	-	0.17 0.05	0.22 0.05	0.47 0.20	0.49 0.20	-	-	0.52 0.21	0.51 0.16	0.53 0.16	-	-
m6	CP20	-	-	0.17 0.05	0.22 0.05	0.54 0.22	-	-	-	0.57 0.23	0.58 0.18	-	-	-
m8	-	-	-	-	-	0.63 0.28	-	-	-	-	-	-	-	-
m10	-	-	-	-	-	0.70 0.33	-	-	-	-	-	-	-	-

## Application Hints



In order to use KHK stock racks safely, carefully read the Application Hints before proceeding. If there are questions or you require clarifications, please contact our technical department or your nearest distributor. E-mail [info@khkgears.net](mailto:info@khkgears.net)  
Please read "Cautions on Performing Secondary Operations" below when performing modifications and/or secondary operations for safety concerns.

### 1. Cautions on Handling

- ① KHK products are packaged one by one to prevent scratches and dents, but if you find issues such as rust, scratches, or dents when the product is removed from the box after purchase, please contact the supplier.
- ② Depending on the handling method, the product may become deformed or damaged. Long racks and plastic racks deform particularly easily, so please handle with care.

### 2. Caution on Performing Secondary Operations

- ① Secondary operations can be performed on all KHK stock racks except for the racks with their gear teeth induction hardened. To avoid problems of gear precision, do not reduce the face width.
- ② Height of pitch lines of racks are controlled by measuring the bottom surface as the reference datum and over-pin measurements on tooth thickness. If you machine the bottom surfaces, the precision of the racks may be affected.
- ③ When connecting two racks, the machining of the mating ends requires careful consideration in terms of the pitch ( $p$ ) accuracy. The meshing will be poor if the pitch straddling the connection has a positive tolerance. We recommend a minus tolerance on pitch of at the connection.  
The below is an indication of pitch tolerance for each module.

$p = \pi \cdot m$   
 $p$  : Reference pitch  
 $\pi$  : Pi  
 $m$  : Module

Module	Pitch ( $p$ )	Tolerance
$m0.5$	1.57	-0.05 -0.15
$m0.8$	2.51	-0.05 -0.25
$m1$	3.14	-0.1 -0.3
$m1.5$	4.71	
$m2$	6.28	-0.1 -0.4
$m2.5$	7.85	
$m3$	9.42	
$m4$	12.57	
$m5$	15.71	
$m6$	18.85	
$m8$	25.13	
$m10$	31.42	

Unit: mm

- ④ To use dowel pins to secure racks, attach the racks to the base and drill both simultaneously.
- ⑤ Products made of S45C and SCM440 can be induction hardened. However, the precision is decreased. There is a decarburized layer (about 0.5 mm) on the block surface. The hardness of the decarburized layer does not increase even if it is quenched.
- ⑥ To be able to handle parts safely, all burrs and sharp corners. should be removed after the secondary operations are done.
- ⑦ If you are going to modify the gear by gripping the teeth, please exercise caution not to crush the teeth by applying too much pressure.

### 3. Points of Caution during Assembly

- ① The recommended assembly distance tolerance of KHK stock racks is H7 for ground racks and H8 for cut racks. Flexible racks need to be adjusted by the customer. The backlash values are given in the table on Page 220. Make sure that the mounting distance stays constant for the length of the rack.

Mounting distance  $a$  = Height of pitch line of rack + Pitch radius of pinion

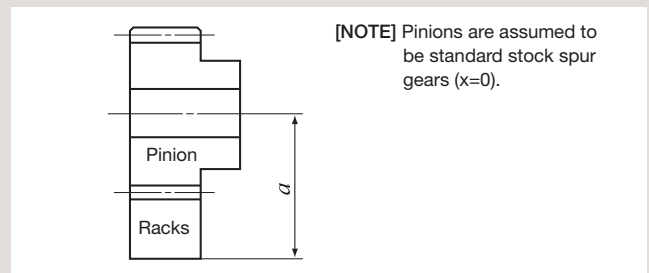

- ② The recommended flatness and squareness of the mounting surface of KHK stock racks is 0.01 mm for ground racks and 0.05 mm for cut racks.

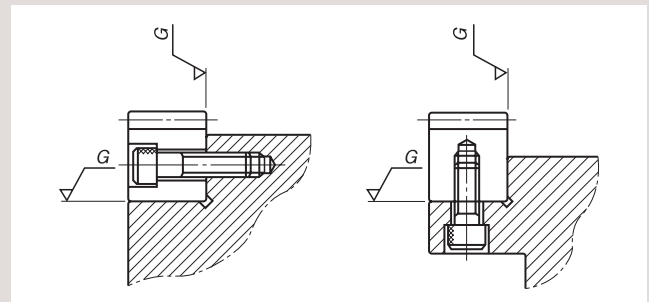

- ③ If the racks are not secured properly to the base, they could shift during operation and cause unexpected problems.  
It is very important to insure firm mounting by the use of dowel pins or similar devices.
- ④ Machined end type racks such as SRF and SRFD series have smaller pitch tolerance at the end face. If you try to connect the racks without any space, the pitch at the connection will be too small and will cause problems. Please follow the diagrams for assembly on the next page.
- ⑤ With SRFD etc., if using more than 10 racks connected together to form a rack with mounting holes machined along a length of 1 meter, the pitch precision and machining precision may cause the rack and base mounting holes to deviate, leading to set screw interference with the counterbored hole and preventing mounting. When using a rack for long lengths such as 10 meters or 20 meters, have the mounting holes additionally machined into long holes.

As an example of Rack Joining, we recommend the following method.

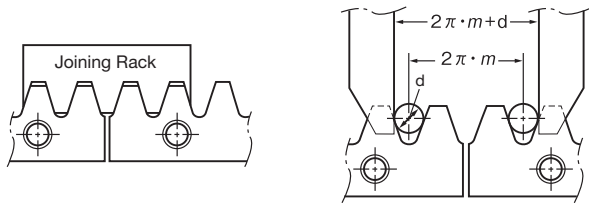

[NOTE] Joining gauge racks for helical racks must have the opposite hand from the racks. Please use 100 mm short racks as a joining gauge rack, or alternatively the rack of the same specifications on hand.

### How to mount racks on a mounting base (For SRFD2-1000)

#### 1. Pitch alignment

Place SRFD2-1000 on the mounting base, align SR2-100 and temporarily tighten the bolt.

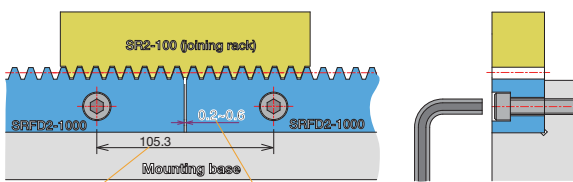

Dimensions Table F Value x 2 SRFD2-1000 is designed to have a gap of 0.2 to 0.6 mm.

#### 2. Securing to the mounting base

Tap with a plastic hammer, bring it into close contact with the mounting base, and further tighten the bolt. (When using a metal hammer, be careful not to damage the gear teeth by using a stiffening plate, etc.)

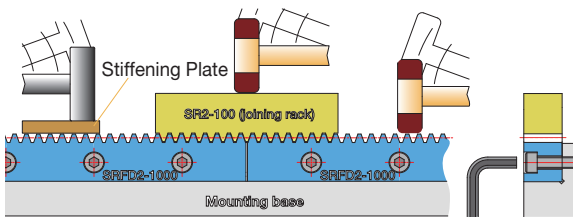

#### 3. Run the pinion and check the following

- ① Is there abnormal noise or vibration?
- ② Is the backlash appropriate?
- ③ Is there poor edge contact of gear teeth?

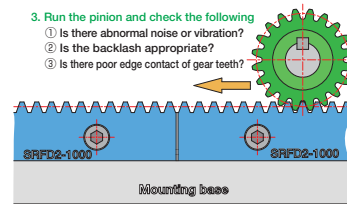

#### 4. Secure fixation to the mounting base

We recommend that you tap the knock pin so that the rack does not shift due to vibration, etc.

- ① Simultaneously machine reamer holes

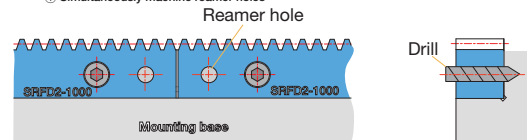

- ② Drive the knock pin

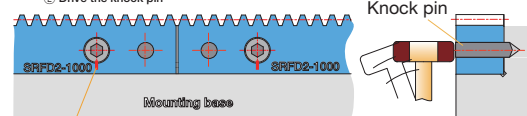

Tighten again after tapping the knock pin. It can be marked with a pen to find looseness.

### 4. Cautions on Starting

- ① Check the following items before starting.
  - Are the gears installed securely?
  - Is there uneven tooth contact?
  - Is there adequate backlash? (Be sure to avoid zero-backlash.)
  - Has proper lubrication been supplied?
- ② If gears are exposed, be sure to attach a safety cover to ensure safety. Also, be careful not to touch rotating gears.
- ③ If there is any abnormality such as noise or vibration during startup, stop the operation immediately and check the assembly condition such as tooth contact, eccentricity and looseness.

KHK considers safety a priority in the use of our products.

When handling, adding secondary operations, assembling, and operating KHK products, please be aware of the following issues in order to prevent accidents.

#### **Warning: Precautions for preventing physical and property damage**

1. When using KHK products, follow relevant safety regulations (Occupational Safety and Health Regulations, etc.).
2. Pay attention to the following items when installing, removing, or performing maintenance and inspection of the product.
  - ① Turn off the power switch.
  - ② Do not reach or crawl under the product.
  - ③ Wear appropriate clothing and protective equipment for the work.

#### **Caution Cautions in Preventing Accidents**

1. Before using a KHK product, read the precautions in the catalog carefully in order to use it correctly.
2. Avoid use in environments that may adversely affect the product.
3. Our products are manufactured under a superior quality control system based on the ISO9001 quality management system; if you notice any malfunctions upon purchasing a product, please contact the supplier.

## Comparison of Racks & Pinions and Ball Screws

Since racks have a simple mechanism, the material, hardening, strength and precision can be designed according to the environment. They are also inexpensive, with parts that can be purchased separately for replacement.

In the designing process, please refer to Features of Racks & Pinions and Ball Screws in the table below.

### ■ Racks & Pinions

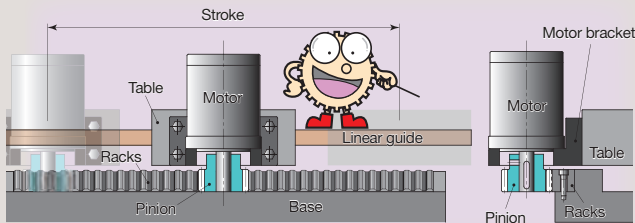

### ■ Ball screw

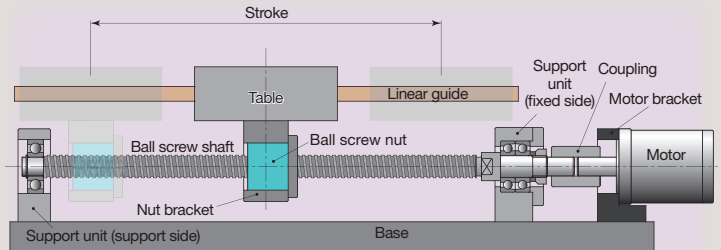

### ● Features of Racks & Pinions

Advantages	Details
Few component parts	Since it does not have parts such as balls and retainers, there is less risk of accidentally falling apart during assembly and disassembly.
Supports heavy loads	Racks with large module can be used for heavy loads.
High transmission efficiency	High transmission efficiency of about 98% (excluding lubrication oil stirring resistance and bearing resistance).
High transport speed	The transport speed can be increased.
No length limit	The racks can be connected and used for a long period of time.
Flexible production is available	Materials, hardening, shapes and the like can be designed flexibly, allowing easy adjustment to the machine.
High-precision products can be manufactured	Gear grinding can be provided to minimize pitch error.
Can be used for food-related machinery	MC nylon and stainless steel products can be manufactured.

Disadvantages	Details
Backlash is present	Backlash is required for smooth rotation. Backlash may become a problem in forward/reverse rotation positioning.
Lubrication is required	Metal racks require lubrication. Plastic racks do not require lubrication at light loads, but their precision is lower.

### ● Features of Ball Screws

Advantages	Details
High transmission efficiency	Transmission efficiency of 90% or higher.
High-precision products can be manufactured	High-precision ball screws can be manufactured by grinding.
No backlash	The use of pressure eliminates backlash.

Disadvantages	Details
Length is limited	There is a limit to the length due to the deflection of the screws.
Hard to manufacture special products	Since it is hard to manufacture special products, machines must be adjusted to the shape of the ball screw.

## Laser Hardened Racks

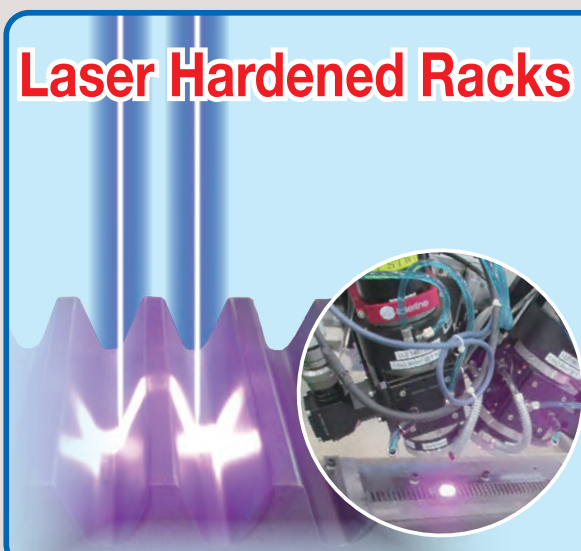

#### ● Lasers used for hardening gear teeth

In this environmentally friendly hardening method, powerful light provides instantaneous hardening and cooling water is not required due to diffusion of heat.

#### ● Can be hardened on surfaces other than the teeth

Lasers excel at spot hardening. As long as the laser can be irradiated, even the inside of bores can be hardened.

#### ● Less distortion due to burning during hardening

As the laser hardens necessary areas in spots, distortion due to burning can be minimized.

Lasers enable hardening that barely changes the precision grade.

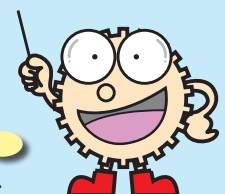

\* Please see Page 236, 238, 260 for products.



Specifications	
Precision grade	KHK R 001 Grade 1 *
Gear teeth	Standard full depth
Pressure angle	20°
Material	SCM415
Heat treatment	Carburized **
Tooth hardness	55 to 60HRC

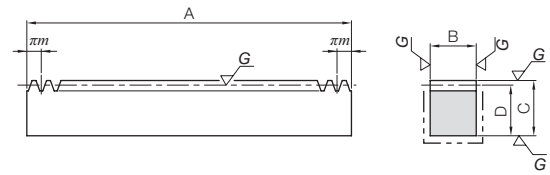

RF

\* The precision grade of J Series products is equivalent to the value shown in the table.  
 \*\* In the illustration, the area surrounded with - - - line is masked during the carburization process (max. HRC40 or so) and can be modified.

Catalog Number	Module	No. of teeth	Shape	Total Length	Face width	Height	Height to pitch line	Allowable force (N)		Allowable force (kgf)	
				A	B	C	D	Bending strength	Surface durability	Bending strength	Surface durability
<b>MRGF1.5-500</b>	<b>m1.5</b>	106	RF	499.51	15	20	18.5	5070	4620	517	472
<b>MRGF2-500</b>	<b>m2</b>	80		502.65	20	25	23	9010	8240	918	840
<b>MRGF2.5-500</b>	<b>m2.5</b>	64		502.65	25	30	27.5	14100	12900	1440	1310
<b>MRGF3-500</b>	<b>m3</b>	53		499.51	30	35	32	20300	18600	2070	1900

Catalog Number ● : J Series (Available-on-request)	Module	No. of teeth	Shape	Total Length	Face width	Height	Height to pitch line	Mounting hole dimensions				
				A	B	C	D	E	F	G	No. of holes	Screw size
● <b>MRGFD1.5-500J</b>	<b>m1.5</b>	106	RD	499.51	15	20	18.5	8	24.76	150	4	M5
● <b>MRGFD2-500J</b>	<b>m2</b>	80		502.65	20	25	23	10	26.33			
● <b>MRGFD2.5-500J</b>	<b>m2.5</b>	64		502.65	25	30	27.5	12	26.33			
● <b>MRGFD3-500J</b>	<b>m3</b>	53		499.51	30	35	32	14	24.76			

[Caution on J series] ① **Cancellation is not possible** for made-to-order products. See page 42 for lead times and allowable order quantities. See page 44 for other precautions.

Surface durability is

**4 times higher** than SRG Hardened Ground Racks,  
**2 times higher** than KRG-H Hardened Ground Racks.



J Series

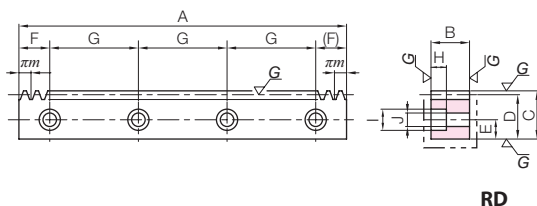

RD



Backlash (mm)	Weight (kg)	Catalog Number
0.04~0.14	1.09	<b>MRGF1.5-500</b>
0.05~0.16	1.82	<b>MRGF2-500</b>
0.05~0.16	2.71	<b>MRGF2.5-500</b>
0.05~0.16	3.76	<b>MRGF3-500</b>

Counterbore dimensions			Allowable force (N)		Allowable force (kgf)		Backlash (mm)	Weight (kg)	Catalog Number ● : J Series (Available-on-request)
H	I	J	Bending strength	Surface durability	Bending strength	Surface durability			
6	10	6	5070	4620	517	472	0.04~0.14	1.07	● <b>MRGFD1.5-500J</b>
7	11	7	9010	8240	918	840	0.05~0.16	1.78	● <b>MRGFD2-500J</b>
8.6	14	9	14100	12900	1440	1310	0.05~0.16	2.64	● <b>MRGFD2.5-500J</b>
10.8	17.5	11	20300	18600	2070	1900	0.05~0.16	3.63	● <b>MRGFD3-500J</b>

Recommended Mating Pinions



MSGA/MSGB Ground Spur Gears

Please see Page 54 for more details.

Rack & Pinion Lubrication System

PUS lubricated spur gear



Page 492

Spur Gears

Helical Gears

Internal Gears

Racks

CP Racks & Pinions

Miter Gears

Bevel Gears

Screw Gears

Worm Gears

Gearboxes

Other Products



- Spur Gears
- Helical Gears
- Internal Gears
- Racks**
- CP Racks & Pinions
- Miter Gears
- Bevel Gears
- Screw Gears
- Worm Gears
- Gearboxes
- Other Products



Specifications	
Precision grade	KHK R 001 Grade 1 *
Gear teeth	Standard full depth
Pressure angle	20°
Material	SCM440
Heat treatment	Thermal refined, gear teeth induction hardened **
Tooth hardness	50 to 60HRC

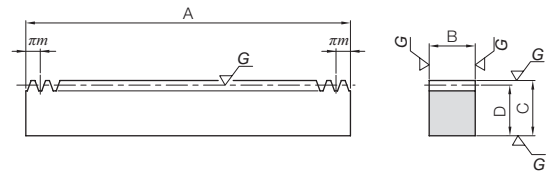

RF

\* The precision grade of J Series products is equivalent to the value shown in the table.  
 \*\* Due to the gear teeth being induction hardened, no secondary operations can be performed on tooth areas including the bottom land (approx. 2 to 3 mm).

Catalog Number	Module	No. of teeth	Shape	Total Length	Face width	Height	Height to pitch line	Allowable force (N)		Allowable force (kgf)	
				A	B	C	D	Bending strength	Surface durability	Bending strength	Surface durability
KRGF1.5-500H KRGF1.5-1000H	m1.5	106	RF	499.51	15	20	18.5	3230	2100	330	215
		212		999.03							
KRGF2-500H KRGF2-1000H	m2	80		502.65	20	25	23	5750	3750	586	382
		160		1005.31							
KRGF2.5-500H KRGF2.5-1000H	m2.5	64		502.65	25	30	27.5	8980	5870	916	598
		128		1005.31							
KRGF3-500H KRGF3-1000H	m3	53	499.51	30	35	32	12900	8470	1320	863	
		106	999.03								

Catalog Number	Module	No. of teeth	Shape	Total Length	Face width	Height	Height to pitch line	Mounting hole dimensions				
				A	B	C	D	E	F	G	No. of holes	Screw size
● KRGFD1.5-500HJ ● KRGFD1.5-1000HJ	m1.5	106	RD	499.51	15	20	18.5	8	24.76	150	4	M5
		212		999.03					49.51	180	6	
● KRGFD2-500HJ ● KRGFD2-1000HJ	m2	80		502.65	20	25	23	10	26.33	150	4	M6
		160		1005.31					52.65	180	6	
● KRGFD2.5-500HJ ● KRGFD2.5-1000HJ	m2.5	64		502.65	25	30	27.5	12	26.33	150	4	M8
		128		1005.31					52.65	180	6	
● KRGFD3-500HJ ● KRGFD3-1000HJ	m3	53	499.51	30	35	32	14	24.76	150	4	M10	
		106	999.03					49.51	180	6		

[Caution on J series] ① Cancellation is not possible for made-to-order products. See page 42 for lead times and allowable order quantities. See page 44 for other precautions.



J Series

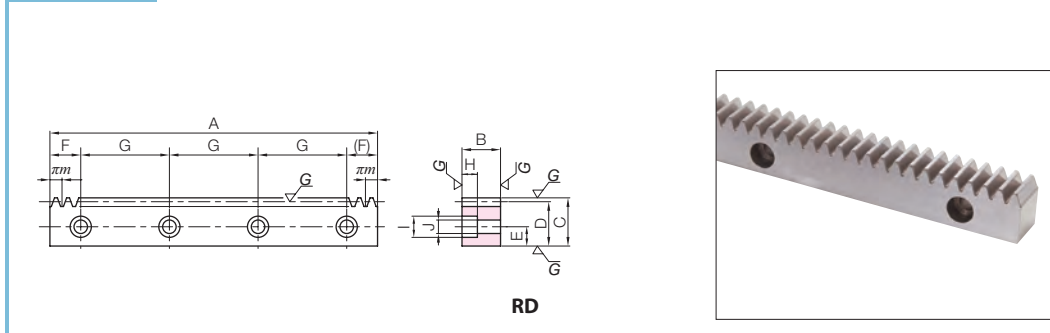

Backlash (mm)	Weight (kg)	Catalog Number
0.04~0.14	1.09 2.18	<b>KRGF1.5-500H</b> <b>KRGF1.5-1000H</b>
0.05~0.16	1.82 3.63	<b>KRGF2-500H</b> <b>KRGF2-1000H</b>
0.05~0.16	2.71 5.43	<b>KRGF2.5-500H</b> <b>KRGF2.5-1000H</b>
0.05~0.16	3.76 7.53	<b>KRGF3-500H</b> <b>KRGF3-1000H</b>

Counterbore dimensions			Allowable force (N)		Allowable force (kgf)		Backlash (mm)	Weight (kg)	Catalog Number ● : J Series (Available-on-request)
H	I	J	Bending strength	Surface durability	Bending strength	Surface durability			
6	10	6	3230	2100	330	215	0.04~0.14	1.07 2.14	● <b>KRGFD1.5-500HJ</b> ● <b>KRGFD1.5-1000HJ</b>
7	11	7	5750	3750	586	382	0.05~0.16	1.78 3.58	● <b>KRGFD2-500HJ</b> ● <b>KRGFD2-1000HJ</b>
8.6	14	9	8980	5870	916	598	0.05~0.16	2.64 5.31	● <b>KRGFD2.5-500HJ</b> ● <b>KRGFD2.5-1000HJ</b>
10.8	17.5	11	12900	8470	1320	863	0.05~0.16	3.63 7.32	● <b>KRGFD3-500HJ</b> ● <b>KRGFD3-1000HJ</b>

Recommended Mating Pinions



KSG Ground Spur Gears

Please see Page 58 for more details.

Rack & Pinion Lubrication System

PUS lubricated spur gear

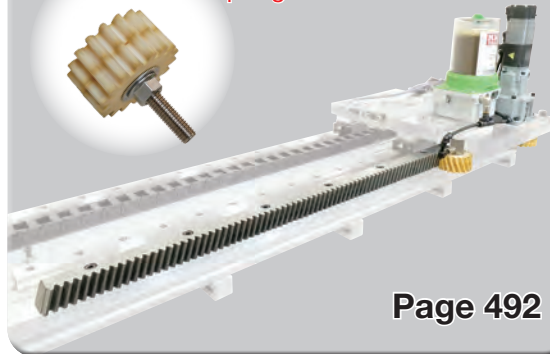

Page 492

Spur Gears

Helical Gears

Internal Gears

Racks

CP Racks & Pinions

Miter Gears

Bevel Gears

Screw Gears

Worm Gears

Gearboxes

Other Products



Specifications	
Precision grade	KHK R 001 grade 1 *
Gear teeth	Standard full depth
Pressure angle	20°
Material	SCM440
Heat treatment	Thermal refining only
Tooth hardness	225 to 352HB

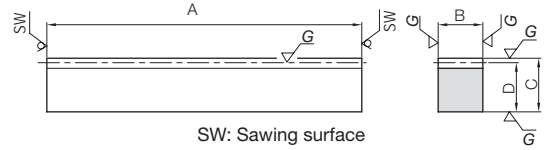

R1

\* The precision grade of J Series products is equivalent to the value shown in the table.

Catalog Number	Module	Effective number of teeth	Shape	Total Length	Face width	Height	Height to pitch line	Allowable force (N)		Allowable force (kgf)	
				A	B	C	D	Bending strength	Surface durability	Bending strength	Surface durability
<b>KRG1-100</b>	<b>m1</b>	29	R1	98	10	15	14	1410	585	144	59.7
<b>KRG1.5-100</b>	<b>m1.5</b>	20		101	15	20	18.5	3180	1320	324	135
<b>KRG2-100</b>	<b>m2</b>	14		98	20	25	23	5650	2350	576	240
<b>KRG2.5-100</b>	<b>m2.5</b>	11		100	25	30	27.5	8830	3680	901	375
<b>KRG3-100</b>	<b>m3</b>	9		101	30	35	32	12700	5310	1300	541

Catalog Number	Module	No. of teeth	Shape	Total Length	Face width	Height	Height to pitch line	Allowable force (N)		Allowable force (kgf)	
				A	B	C	D	Bending strength	Surface durability	Bending strength	Surface durability
<b>KRGF1-500</b> <b>KRGF1-1000</b>	<b>m1</b>	159 318	RF	499.51 999.03	10	15	14	1410	585	144	59.7
<b>KRGF1.5-500</b> <b>KRGF1.5-1000</b>	<b>m1.5</b>	106 212		499.51 999.03	15	20	18.5	3180	1320	324	135
<b>KRGF2-500</b> <b>KRGF2-1000</b>	<b>m2</b>	80 160		502.65 1005.31	20	25	23	5650	2350	576	240
<b>KRGF2.5-500</b> <b>KRGF2.5-1000</b>	<b>m2.5</b>	64 128		502.65 1005.31	25	30	27.5	8830	3680	901	375
<b>KRGF3-500</b> <b>KRGF3-1000</b>	<b>m3</b>	53 106		499.51 999.03	30	35	32	12700	5310	1300	541

Catalog Number	Module	No. of teeth	Shape	Total Length	Face width	Height	Height to pitch line	Mounting hole dimensions				
				A	B	C	D	E	F	G	No. of holes	Screw size
● <b>KRGFD1-500J</b> ● <b>KRGFD1-1000J</b>	<b>m1</b>	159 318	RD	499.51 999.03	10	15	14	6	24.76 49.51	150 180	4 6	M4
● <b>KRGFD1.5-500J</b> ● <b>KRGFD1.5-1000J</b>	<b>m1.5</b>	106 212		499.51 999.03	15	20	18.5	8	24.76 49.51	150 180	4 6	M5
● <b>KRGFD2-500J</b> ● <b>KRGFD2-1000J</b>	<b>m2</b>	80 160		502.65 1005.31	20	25	23	10	26.33 52.65	150 180	4 6	M6
● <b>KRGFD2.5-500J</b> ● <b>KRGFD2.5-1000J</b>	<b>m2.5</b>	64 128		502.65 1005.31	25	30	27.5	12	26.33 52.65	150 180	4 6	M8
● <b>KRGFD3-500J</b> ● <b>KRGFD3-1000J</b>	<b>m3</b>	53 106		499.51 999.03	30	35	32	14	24.76 49.51	150 180	4 6	M10

[Caution on J series] ① **Cancellation is not possible** for made-to-order products. See page 42 for lead times and allowable order quantities. See page 44 for other precautions.



J Series

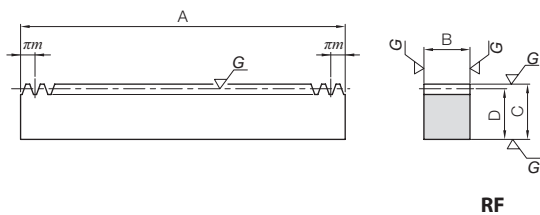

RF

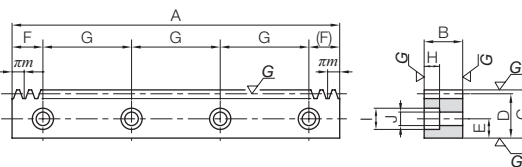

RD

Backlash (mm)	Weight (kg)	Catalog Number
0.04~0.14	0.11	<b>KRG1-100</b>
0.04~0.14	0.22	<b>KRG1.5-100</b>
0.05~0.16	0.35	<b>KRG2-100</b>
0.05~0.16	0.54	<b>KRG2.5-100</b>
0.05~0.16	0.76	<b>KRG3-100</b>

Backlash (mm)	Weight (kg)	Catalog Number
0.04~0.14	0.55 1.49	<b>KRGF1-500</b> <b>KRGF1-1000</b>
0.04~0.14	1.09 2.18	<b>KRGF1.5-500</b> <b>KRGF1.5-1000</b>
0.05~0.16	1.82 3.63	<b>KRGF2-500</b> <b>KRGF2-1000</b>
0.05~0.16	2.71 5.43	<b>KRGF2.5-500</b> <b>KRGF2.5-1000</b>
0.05~0.16	3.76 7.53	<b>KRGF3-500</b> <b>KRGF3-1000</b>

Counterbore dimensions			Allowable force (N)		Allowable force (kgf)		Backlash (mm)	Weight (kg)	Catalog Number ● : J Series (Available-on-request)
H	I	J	Bending strength	Surface durability	Bending strength	Surface durability			
5	8	4.5	1410	585	144	59.7	0.04~0.14	0.54 1.08	● <b>KRGFD1-500J</b> ● <b>KRGFD1-1000J</b>
6	10	6	3180	1320	324	135	0.04~0.14	1.07 2.14	● <b>KRGFD1.5-500J</b> ● <b>KRGFD1.5-1000J</b>
7	11	7	5650	2350	576	240	0.05~0.16	1.78 3.58	● <b>KRGFD2-500J</b> ● <b>KRGFD2-1000J</b>
8.6	14	9	8830	3680	901	375	0.05~0.16	2.64 5.31	● <b>KRGFD2.5-500J</b> ● <b>KRGFD2.5-1000J</b>
10.8	17.5	11	12700	5310	1300	541	0.05~0.16	3.62 7.32	● <b>KRGFD3-500J</b> ● <b>KRGFD3-1000J</b>

\* Module 10 and ground racks with total lengths up to (A) 1500mm and heights up to (C) 120mm are also available by request as custom-made products.

Recommended Mating Pinions



SSG Ground Spur Gears

Please see Page 62 for more details.

Rack & Pinion Lubrication System

PUS lubricated spur gear



Page 492

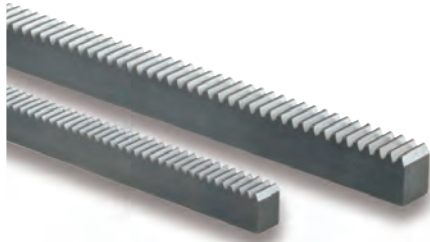

Specifications	
Precision grade	KHK R 001 Grade 3 *
Gear teeth	Standard full depth
Pressure angle	20°
Material	S45C
Heat treatment	Gear teeth induction hardened **
Tooth hardness	50 to 60HRC ***
Surface treatment	Black oxide coated except for teeth

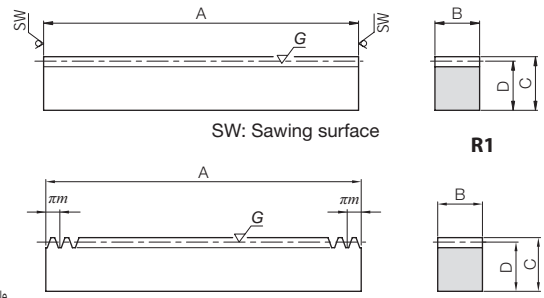

\* The precision grade of J Series products is equivalent to the value shown in the table.  
 \*\* Due to the gear teeth being induction hardened, no secondary operations can be performed on tooth areas including the bottom land (approx. 2 to 3mm).  
 \*\*\* Products with modules of 0.8 or under use S45C thermal refined materials, so the surface hardness is 200-270 HB.

Catalog Number	Module	Effective number of teeth	Shape	Total Length	Face width	Height	Height to pitch line	Allowable force (N)		Allowable force (kgf)		Backlash (mm)	Weight (kg)
				A	B	C	D	Bending strength	Surface durability	Bending strength	Surface durability		
SRG0.5-100 (Made to Order)	m0.5	61	R1	101	5	12	11.5	293	80.5	29.9	8.21	0~0.11	0.046
SRG0.8-100 (Made to Order)	m0.8	38		101	8	12.3	11.5	751	206	76.6	21.0	0~0.12	0.073
SRG1-100	m1	29	R1	98	10	12	11	862	514	87.9	52.4	0.04~0.19	0.085
SRG1.5-100	m1.5	20		101	15	20	18.5	2160	1360	220	138	0.04~0.19	0.22
SRG2-100	m2	14		98	20	25	23	3830	2410	391	246	0.05~0.21	0.35
SRG2.5-100	m2.5	11		100	25	30	27.5	5990	3770	611	384	0.05~0.21	0.54
SRG3-100	m3	9	R1	101	30	35	32	8620	5420	879	553	0.05~0.21	0.76
SRG4-100	m4	6		98	40	45	41	15300	9640	1560	983	0.05~0.21	1.26
SRG5-110	m5	5		108	50	50	45	24000	15100	2440	1540	0.05~0.22	1.91
SRG6-110	m6	4	R1	111	60	60	54	34500	21700	3520	2210	0.05~0.22	2.82

Catalog Number	Module	No. of teeth	Shape	Total Length	Face width	Height	Height to pitch line	Allowable force (N)		Allowable force (kgf)		Backlash (mm)	Weight (kg)
				A	B	C	D	Bending strength	Surface durability	Bending strength	Surface durability		
SRGF0.5-300 (Made to Order)	m0.5	191	RF	300.02	5	12	11.5	293	80.5	29.9	8.21	0~0.11	0.14
SRGF0.8-300 (Made to Order)	m0.8	119		299.08	8	12.3	11.5	751	206	76.6	21.0	0~0.12	0.22
SRGF1-300	m1	96	RF	301.59	10	12	11	862	514	87.9	52.4	0.04~0.19	0.26
SRGF1-500		159		499.51									
SRGF1.5-500	m1.5	106		499.51	15	20	18.5	2160	1360	220	138	0.04~0.19	1.09
SRGF1.5-1000		212		999.03									
SRGF2-500	m2	80		502.65	20	25	23	3830	2410	391	246	0.05~0.21	1.82
SRGF2-1000		160		1005.31									
SRGF2.5-500	m2.5	64		502.65	25	30	27.5	5990	3770	611	384	0.05~0.21	2.71
SRGF2.5-1000		128		1005.31									
SRGF3-500	m3	53		499.51	30	35	32	8620	5420	879	553	0.05~0.21	3.76
SRGF3-1000		106		999.03									
SRGF4-500	m4	40	502.65	40	45	41	15300	9640	1560	983	0.05~0.21	6.47	
SRGF4-1000		80	1005.31										12.9
SRGF5-500	m5	32	502.65	50	50	45	24000	15100	2440	1540	0.05~0.22	8.88	
SRGF5-1000		64	1005.31										17.8
SRGF6-500	m6	26	490.09	60	60	54	34500	21700	3520	2210	0.05~0.22	12.5	
SRGF6-1000		53	999.03										25.4

Catalog Number	Module	No. of teeth	Shape	Total Length	Face width	Height	Height to pitch line	Mounting hole dimensions				
				A	B	C	D	E	F	G	No. of holes	Screw size
● SRGFK1-300J	m1	96	RD	301.59	10	12	11	5	20.80	130	3	M4
● SRGFK1-500J		159		499.51								
● SRGFD1.5-500J	m1.5	106		499.51	15	20	18.5	8	24.76	150	4	M5
● SRGFD1.5-1000J		212		999.03								
● SRGFD2-500J	m2	80		502.65	20	25	23	10	26.33	150	4	M6
● SRGFD2-1000J		160		1005.31								
● SRGFD2.5-500J	m2.5	64		502.65	25	30	27.5	12	26.33	150	4	M8
● SRGFD2.5-1000J		128		1005.31								
● SRGFD3-500J	m3	53		499.51	30	35	32	14	24.76	150	4	M10
● SRGFD3-1000J		106		999.03								
● SRGFD4-500J	m4	40	502.65	40	45	41	18	26.33	150	4	M12	
● SRGFD4-1000J		80	1005.31									180
● SRGFD5-500J	m5	32	502.65	50	50	45	20	31.33	220	3	M14	
● SRGFD5-1000J		64	1005.31									220
● SRGFD6-500J	m6	26	490.09	60	60	54	23	25.04	220	3	M16	
● SRGFD6-1000J		53	999.03									220



J Series

PUS lubricated spur gear



Please see Page 494 for more details.

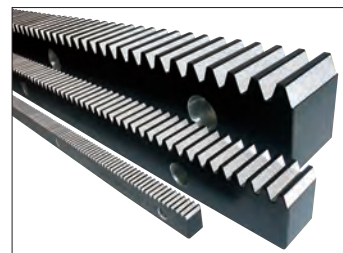
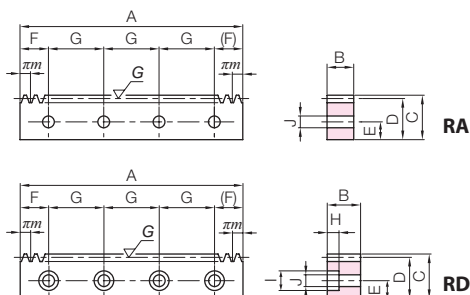

Recommended Mating Pinions



SSG Ground Spur Gears

Please see Page 62 for more details.



SSGS Ground Spur Gears

Please see Page 60 for more details.

[Caution on J series] ① Cancellation is not possible for made-to-order products. See page 42 for lead times and allowable order quantities. See page 44 for other precautions.

[Precautions for Made to Order Products] ① Prices and lead times for Made to Order products require separate estimates. Contact your dealer.

Counterbore dimensions			Allowable force (N)		Allowable force (kgf)		Backlash (mm)	Weight (kg)	Catalog Number ● : J Series (Available-on-request)
H	I	J	Bending strength	Surface durability	Bending strength	Surface durability			
—	—	4.5	862	514	87.9	52.4	0.04~0.19	0.26 0.43	● SRGFK1-300J ● SRGFK1-500J
6	10	6	2160	1360	220	138	0.04~0.19	1.07 2.14	● SRGFD1.5-500J ● SRGFD1.5-1000J
7	11	7	3830	2410	391	246	0.05~0.21	1.78 3.58	● SRGFD2-500J ● SRGFD2-1000J
8.6	14	9	5990	3770	611	384	0.05~0.21	2.64 5.31	● SRGFD2.5-500J ● SRGFD2.5-1000J
10.8	17.5	11	8620	5420	879	553	0.05~0.21	3.63 7.32	● SRGFD3-500J ● SRGFD3-1000J
13	20	14	15300	9640	1560	983	0.05~0.21	6.21 12.6	● SRGFD4-500J ● SRGFD4-1000J
15.2	23	16	24000	15100	2440	1540	0.05~0.22	8.56 17.2	● SRGFD5-500J ● SRGFD5-1000J
17.5	26	18	34500	21700	3520	2210	0.05~0.22	12.0 24.6	● SRGFD6-500J ● SRGFD6-1000J



Specifications	
Precision grade	KHK R 001 grade 5 *
Gear teeth	Standard full depth
Pressure angle	20°
Material	SCM440
Heat treatment	Thermal refined, gear teeth induction hardened **
Tooth hardness	50 to 60HRC
Surface treatment	Black oxide coating

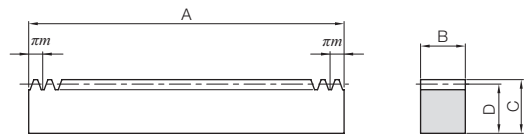

RF

\* The precision grade is equivalent to the value shown in the table.  
 \*\* The dimensions may vary due to hardening. Therefore, the total composite error is excluded from the rack accuracy table on Page 219.  
 \*\* Due to the gear teeth being induction hardened, no secondary operations can be performed on tooth areas including the bottom land (approx. 2 to 3 mm).

Catalog Number	Module	No. of teeth	Shape	Total Length	Face width	Height	Height to pitch line	Allowable force (N)		Allowable force (kgf)	
				A	B	C	D	Bending strength	Surface durability	Bending strength	Surface durability
<b>KRF1.5-1000H</b>	<b>m1.5</b>	212	RF	999.03	15	20	18.5	2940	1710	300	175
<b>KRF2-1000H</b>	<b>m2</b>	160		1005.31	20	25	23	5230	3090	533	315
<b>KRF2.5-1000H</b>	<b>m2.5</b>	128		1005.31	25	30	27.5	8170	4890	833	499
<b>KRF3-1000H</b>	<b>m3</b>	106		999.03	30	35	32	11800	7110	1200	725
<b>KRF4-1000H</b>	<b>m4</b>	80		1005.31	40	45	41	20900	12900	2130	1310
<b>KRF5-1000H</b>	<b>m5</b>	64		1005.31	50	50	45	32700	20400	3330	2080

Catalog Number	Module	No. of teeth	Shape	Total Length	Face width	Height	Height to pitch line	Mounting hole dimensions				
				A	B	C	D	E	F	G	No. of holes	Screw size
● <b>KRFD1.5-1000HJ</b>	<b>m1.5</b>	212	RD	999.03	15	20	18.5	8	49.51	180	6	M5
● <b>KRFD2-1000HJ</b>	<b>m2</b>	160		1005.31	20	25	23	10	52.65	180	6	M6
● <b>KRFD2.5-1000HJ</b>	<b>m2.5</b>	128		1005.31	25	30	27.5	12	52.65	180	6	M8
● <b>KRFD3-1000HJ</b>	<b>m3</b>	106		999.03	30	35	32	14	49.51	180	6	M10
● <b>KRFD4-1000HJ</b>	<b>m4</b>	80		1005.31	40	45	41	18	52.65	180	6	M12
● <b>KRFD5-1000HJ</b>	<b>m5</b>	64		1005.31	50	50	45	20	62.65	220	5	M14

[Caution on J series] ① Cancellation is not possible for made-to-order products. See page 42 for lead times and allowable order quantities. See page 44 for other precautions.

- Spur Gears
- Helical Gears
- Internal Gears
- Racks**
- CP Racks & Pinions
- Miter Gears
- Bevel Gears
- Screw Gears
- Worm Gears
- Gearboxes
- Other Products



J Series

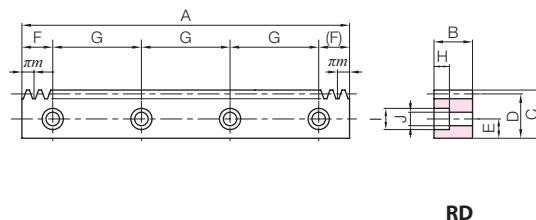

Backlash (mm)	Weight (kg)	Catalog Number
0.05~0.31	2.18	<b>KRF1.5-1000H</b>
0.07~0.34	3.63	<b>KRF2-1000H</b>
0.09~0.37	5.43	<b>KRF2.5-1000H</b>
0.10~0.41	7.53	<b>KRF3-1000H</b>
0.14~0.48	12.9	<b>KRF4-1000H</b>
0.16~0.53	17.8	<b>KRF5-1000H</b>

Counterbore dimensions			Allowable force (N)		Allowable force (kgf)		Backlash (mm)	Weight (kg)	Catalog Number ● : J Series (Available-on-request)
H	I	J	Bending strength	Surface durability	Bending strength	Surface durability			
6	10	6	2940	1710	300	175	0.05~0.31	2.14	● <b>KRFD1.5-1000HJ</b>
7	11	7	5230	3090	533	315	0.07~0.34	3.58	● <b>KRFD2-1000HJ</b>
8.6	14	9	8170	4890	833	499	0.09~0.37	5.31	● <b>KRFD2.5-1000HJ</b>
10.8	17.5	11	11800	7110	1200	725	0.10~0.41	7.32	● <b>KRFD3-1000HJ</b>
13	20	14	20900	12900	2130	1310	0.14~0.48	12.6	● <b>KRFD4-1000HJ</b>
15.2	23	16	32700	20400	3330	2080	0.16~0.53	17.2	● <b>KRFD5-1000HJ</b>

Spur Gears

Helical Gears

Internal Gears

**Racks**

CP Racks & Pinions

Miter Gears

Bevel Gears

Screw Gears

Worm Gears

Gearboxes

Other Products



Specifications	
Precision grade	KHK R 001 grade 5 *
Gear teeth	Standard full depth
Pressure angle	20°
Material	S45C
Heat treatment	Gear teeth induction hardened **
Tooth hardness	50 to 60HRC
Surface treatment	Black oxide coating

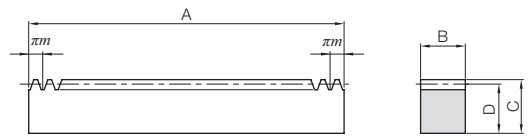

RF

\* The precision grade is equivalent to the value shown in the table.

\*\* The dimensions may vary due to hardening. Therefore, the total composite error is excluded from the rack accuracy table on Page 219.

\*\* Due to the gear teeth being induction hardened, no secondary operations can be performed on tooth areas including the bottom land (approx. 2 to 3 mm).

Catalog Number	Module	No. of teeth	Shape	Total Length	Face width	Height	Height to pitch line	Allowable force (N)		Allowable force (kgf)	
				A	B	C	D	Bending strength	Surface durability	Bending strength	Surface durability
SRF1.5-1000H	m1.5	212	RF	999.03	15	20	18.5	1960	1110	200	113
SRF2-1000H	m2	160		1005.31	20	25	23	3480	2000	355	204
SRF2.5-1000H	m2.5	128		1005.31	25	30	27.5	5440	3160	555	322
SRF3-1000H	m3	106		999.03	30	35	32	7840	4590	799	468
SRF4-1000H	m4	80		1005.31	40	45	41	13900	8310	1420	847
SRF5-1000H	m5	64		1005.31	50	50	45	21800	13200	2220	1340
SRF6-1000H	m6	53	999.03	60	60	54	31400	19200	3200	1960	

Catalog Number	Module	No. of teeth	Shape	Total Length	Face width	Height	Height to pitch line	Mounting hole dimensions				
				A	B	C	D	E	F	G	No. of holes	Screw size
● SRFD1.5-1000HJ	m1.5	212	RD	999.03	15	20	18.5	8	49.51	180	6	M5
● SRFD2-1000HJ	m2	160		1005.31	20	25	23	10	52.65	180	6	M6
● SRFD2.5-1000HJ	m2.5	128		1005.31	25	30	27.5	12	52.65	180	6	M8
● SRFD3-1000HJ	m3	106		999.03	30	35	32	14	49.51	180	6	M10
● SRFD4-1000HJ	m4	80		1005.31	40	45	41	18	52.65	180	6	M12
● SRFD5-1000HJ	m5	64		1005.31	50	50	45	20	62.65	220	5	M14
● SRFD6-1000HJ	m6	53	999.03	60	60	54	23	59.51	220	5	M16	

[Caution on J series] ① Cancellation is not possible for made-to-order products. See page 42 for lead times and allowable order quantities. See page 44 for other precautions.



J Series

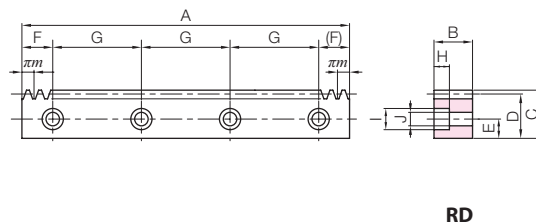

RD

Backlash (mm)	Weight (kg)	Catalog Number
0.05~0.29	2.18	<b>SRF1.5-1000H</b>
0.07~0.32	3.63	<b>SRF2-1000H</b>
0.09~0.35	5.43	<b>SRF2.5-1000H</b>
0.10~0.39	7.53	<b>SRF3-1000H</b>
0.14~0.46	12.9	<b>SRF4-1000H</b>
0.16~0.51	17.8	<b>SRF5-1000H</b>
0.18~0.58	25.4	<b>SRF6-1000H</b>

Counterbore dimensions			Allowable force (N)		Allowable force (kgf)		Backlash (mm)	Weight (kg)	Catalog Number ● : J Series (Available-on-request)
H	I	J	Bending strength	Surface durability	Bending strength	Surface durability			
6	10	6	1960	1110	200	113	0.05~0.29	2.14	● <b>SRFD1.5-1000HJ</b>
7	11	7	3480	2000	355	204	0.07~0.32	3.58	● <b>SRFD2-1000HJ</b>
8.6	14	9	5440	3160	555	322	0.09~0.35	5.31	● <b>SRFD2.5-1000HJ</b>
10.8	17.5	11	7840	4590	799	468	0.10~0.39	7.32	● <b>SRFD3-1000HJ</b>
13	20	14	13900	8310	1420	847	0.14~0.46	12.6	● <b>SRFD4-1000HJ</b>
15.2	23	16	21800	13200	2220	1340	0.16~0.51	17.2	● <b>SRFD5-1000HJ</b>
17.5	26	18	31400	19200	3200	1960	0.18~0.58	24.6	● <b>SRFD6-1000HJ</b>

## Recommended Mating Pinions



### SS- Hardened Spur Gears

Please see Page 110 for more details.

Spur Gears

Helical Gears

Internal Gears

Racks

CP Racks & Pinions

Miter Gears

Bevel Gears

Screw Gears

Worm Gears

Gearboxes

Other Products

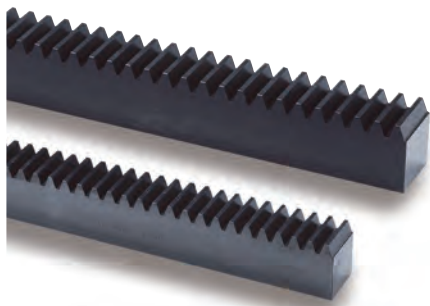

Specifications	
Precision grade	KHK R 001 Grade 4 *
Gear teeth	Standard full depth
Pressure angle	20°
Material	S45C
Heat treatment	Gear teeth laser hardened **
Tooth hardness	55 to 65HRC
Surface treatment	Black oxide coating

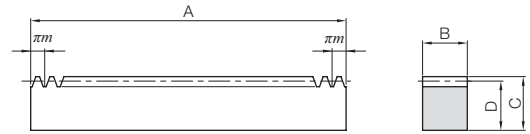

RF

\* The precision grade is equivalent to the value shown in the table.  
 \*\* Due to the gear teeth being laser hardened, no secondary operations can be performed on tooth areas including the bottom land (approx. 1 mm).

Catalog Number	Module	No. of teeth	Shape	Total Length	Face width	Height	Height to pitch line	Allowable force (N)		Allowable force (kgf)		Backlash (mm)	Weight (kg)
				A	B	C	D	Bending strength	Surface durability	Bending strength	Surface durability		
SRF1.5-1000HL	m1.5	212	RF	999.03	15	20	18.5	2160	961	220	98.0	0.09~0.25	2.18
SRF1.5-1500HL		320		1507.96									
SRF1.5-2000HL		435		2049.88									
SRF2-1000HL	m2	160		1005.31	20	25	23	3830	1730	391	177	0.11~0.28	3.63
SRF2-1500HL		240		1507.96									
SRF2-2000HL		326		2048.31									
SRF2.5-1000HL	m2.5	128		1005.31	25	30	27.5	5990	2740	611	280	0.13~0.31	5.43
SRF2.5-1500HL		192		1507.96									
SRF2.5-2000HL		261		2049.88									
SRF3-1000HL	m3	106		999.03	30	35	32	8620	3990	879	407	0.14~0.35	7.53
SRF3-1500HL		160		1507.96									
SRF3-2000HL		217		2045.17									
SRF4-1000HL	m4	80	1005.31	40	45	41	15300	7220	1560	736	0.18~0.42	12.9	
SRF4-1500HL		120	1507.96										
SRF4-2000HL		163	2048.31										
SRF5-1000HL	m5	64	1005.31	50	50	45	24000	11400	2440	1170	0.20~0.47	17.8	
SRF5-1500HL		96	1507.96										
SRF5-2000HL		130	2042.04										
SRF6-1000HL	m6	53	999.03	60	60	54	34500	16700	3520	1700	0.22~0.54	25.4	
SRF6-1500HL		80	1507.96										
SRF6-2000HL		108	2035.75										

Catalog Number	Module	No. of teeth	Shape	Total Length	Face width	Height	Height to pitch line	Mounting hole dimensions				
				A	B	C	D	E	F	G	No. of holes	Screw size
SRFD1.5-1000HLJ	m1.5	212	RD	999.03	15	20	18.5	8	49.51	180	6	M5
SRFD1.5-1500HLJ		320		1507.96								
SRFD1.5-2000HLJ		435		2049.88								
SRFD2-1000HLJ	m2	160		1005.31	20	25	23	10	52.65	180	6	M6
SRFD2-1500HLJ		240		1507.96								
SRFD2-2000HLJ		326		2048.31								
SRFD2.5-1000HLJ	m2.5	128		1005.31	25	30	27.5	12	52.65	180	6	M8
SRFD2.5-1500HLJ		192		1507.96								
SRFD2.5-2000HLJ		261		2049.88								
SRFD3-1000HLJ	m3	106		999.03	30	35	32	14	49.51	180	6	M10
SRFD3-1500HLJ		160		1507.96								
SRFD3-2000HLJ		217		2045.17								
SRFD4-1000HLJ	m4	80	1005.31	40	45	41	18	52.65	180	6	M12	
SRFD4-1500HLJ		120	1507.96									
SRFD4-2000HLJ		163	2048.31									
SRFD5-1000HLJ	m5	64	1005.31	50	50	45	20	62.65	220	5	M14	
SRFD5-1500HLJ		96	1507.96									
SRFD5-2000HLJ		130	2042.04									
SRFD6-1000HLJ	m6	53	999.03	60	60	54	23	59.51	220	5	M16	
SRFD6-1500HLJ		80	1507.96									
SRFD6-2000HLJ		108	2035.75									

[Caution on J series] ① Cancellation is not possible for made-to-order products. See page 42 for lead times and allowable order quantities. See page 44 for other precautions.



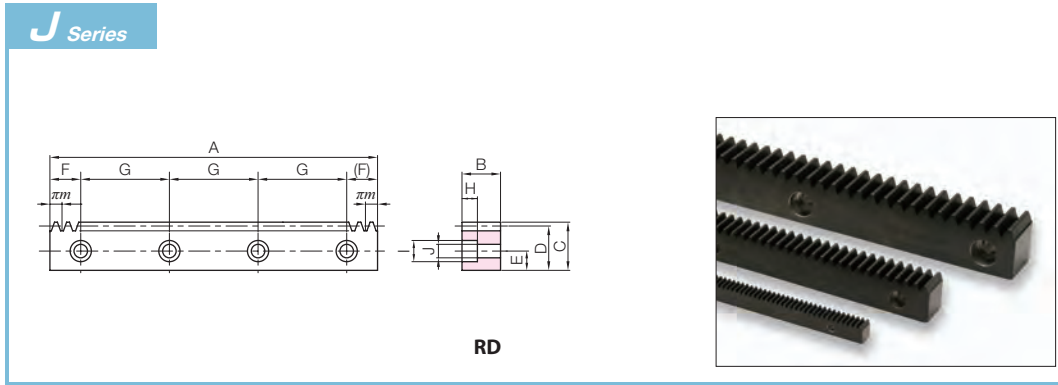

\* Total length change just 1/12 compared to induction hardening! These hardened racks have minimal deformation due to heat treatment.

**Laser hardened total length change**

With induction hardening



With laser hardening



\* This is a measurement of the total length change (cumulative pitch) when induction hardening and laser hardening are applied to SRF3-1000.

**Recommended Mating Pinions**



SS- Hardened Spur Gears

Please see Page 110 for more details.

Counterbore dimensions			Allowable force (N)		Allowable force (kgf)		Backlash (mm)	Weight (kg)	Catalog Number ● : J Series (Available-on-request)
H	I	J	Bending strength	Surface durability	Bending strength	Surface durability			
6	10	6	2160	961	220	98.0	0.09~0.25	2.14 3.23 4.40	●SRFD1.5-1000HLJ ●SRFD1.5-1500HLJ ●SRFD1.5-2000HLJ
7	11	7	3830	1730	391	177	0.11~0.28	3.58 5.36 7.29	●SRFD2-1000HLJ ●SRFD2-1500HLJ ●SRFD2-2000HLJ
8.6	14	9	5990	2740	611	280	0.13~0.31	5.31 7.97 10.8	●SRFD2.5-1000HLJ ●SRFD2.5-1500HLJ ●SRFD2.5-2000HLJ
10.8	17.5	11	8620	3990	879	407	0.14~0.35	7.32 11.1 15.0	●SRFD3-1000HLJ ●SRFD3-1500HLJ ●SRFD3-2000HLJ
13	20	14	15300	7220	1560	736	0.18~0.42	12.6 18.8 25.6	●SRFD4-1000HLJ ●SRFD4-1500HLJ ●SRFD4-2000HLJ
15.2	23	16	24000	11400	2440	1170	0.20~0.47	17.2 25.9 35.0	●SRFD5-1000HLJ ●SRFD5-1500HLJ ●SRFD5-2000HLJ
17.5	26	18	34500	16700	3520	1700	0.22~0.54	24.6 37.2 50.2	●SRFD6-1000HLJ ●SRFD6-1500HLJ ●SRFD6-2000HLJ



Specifications	
Precision grade	KHK R 001 Grade 4 *
Gear teeth	Standard full depth
Pressure angle	20°
Material	S45C
Heat treatment	Gear teeth laser hardened **
Tooth hardness	55 to 65HRC
Surface treatment	Black oxide coating

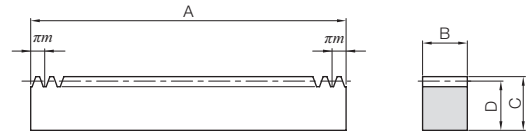

RF

\* The precision grade is equivalent to the value shown in the table.  
 \*\* Due to the gear teeth being laser hardened, no secondary operations can be performed on tooth areas including the bottom land (approx. 1 mm).

Catalog Number	Module	No. of teeth	Shape	Total Length				Allowable force (N)		Allowable force (kgf)	
				A	B	C	D	Bending strength	Surface durability	Bending strength	Surface durability
<b>SRAF1.5-1000HL</b>	<b>m1.5</b>	212	RF	999.03	15	15	13.5	2160	961	220	98
<b>SRAF2-1000HL</b>	<b>m2</b>	160		1005.31	20	20	18	3830	1730	391	177
<b>SRAF2.5-1000HL</b>	<b>m2.5</b>	128		1005.31	25	25	22.5	5990	2740	611	280
<b>SRAF3-1000HL</b>	<b>m3</b>	106		999.03	30	30	27	8620	3990	879	407
<b>SRAF4-1000HL</b>	<b>m4</b>	80		1005.31	40	40	36	15300	7220	1560	736

Catalog Number	Module	No. of teeth	Shape	Total Length				Mounting hole dimensions					
				A	B	C	D	E	F	G	No. of holes	Screw size	
● <b>SRAFK1.5-1000HLJ</b>	<b>m1.5</b>	212	RA	999.03	15	15	13.5	5	49.51	180	6	M5	
● <b>SRAFD2-1000HLJ</b>	<b>m2</b>	160	RD	1005.31	20	20	18	7	52.65			M6	
● <b>SRAFD2.5-1000HLJ</b>	<b>m2.5</b>	128	RD	1005.31	25	25	22.5	9	52.65			M8	
● <b>SRAFD3-1000HLJ</b>	<b>m3</b>	106	RD	999.03	30	30	27	11	49.51			M10	
● <b>SRAFD4-1000HLJ</b>	<b>m4</b>	80	RD	1005.31	40	40	36	15	52.65			M12	

[Caution on J series] ① Cancellation is not possible for made-to-order products. See page 42 for lead times and allowable order quantities. See page 44 for other precautions.

- Spur Gears
- Helical Gears
- Internal Gears
- Racks
- CP Racks & Pinions
- Miter Gears
- Bevel Gears
- Screw Gears
- Worm Gears
- Gearboxes
- Other Products



J Series

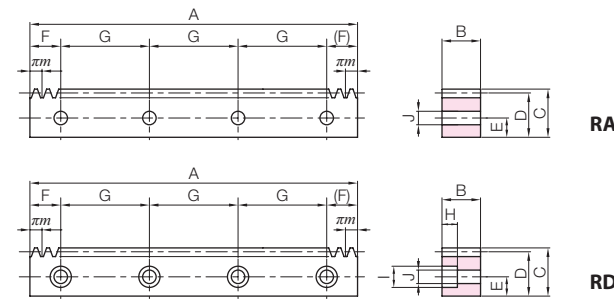

RA

RD

Backlash (mm)	Weight (kg)	Catalog Number
0.09~0.25	1.59	<b>SRAF1.5-1000HL</b>
0.11~0.28	2.84	<b>SRAF2-1000HL</b>
0.13~0.31	4.44	<b>SRAF2.5-1000HL</b>
0.14~0.35	6.35	<b>SRAF3-1000HL</b>
0.18~0.42	11.4	<b>SRAF4-1000HL</b>

Counterbore dimensions			Allowable force (N)		Allowable force (kgf)		Backlash (mm)	Weight (kg)	Catalog Number ● : J Series (Available-on-request)
H	I	J	Bending strength	Surface durability	Bending strength	Surface durability			
—	—	6	2160	961	220	98	0.09~0.25	1.57	● <b>SRAFK1.5-1000HLJ</b>
7	11	7	3830	1730	391	177	0.11~0.28	2.79	● <b>SRAFD2-1000HLJ</b>
8.6	14	9	5990	2740	611	280	0.13~0.31	4.33	● <b>SRAFD2.5-1000HLJ</b>
10.8	17.5	11	8620	3990	879	407	0.14~0.35	6.14	● <b>SRAFD3-1000HLJ</b>
13	20	14	15300	7220	1560	736	0.18~0.42	11.0	● <b>SRAFD4-1000HLJ</b>

## Recommended Mating Pinions



SS-  Hardened Spur Gears

Please see Page 110 for more details.

Spur Gears

Helical Gears

Internal Gears

Racks

CP Racks & Pinions

Miter Gears

Bevel Gears

Screw Gears

Worm Gears

Gearboxes

Other Products



Specifications	
Precision grade	KHK R 001 Grade 4 *
Gear teeth	Standard full depth
Pressure angle	20°
Material	SCM440
Heat treatment	Thermal refining only
Tooth hardness	225 to 352HB
Surface treatment	Black oxide coating

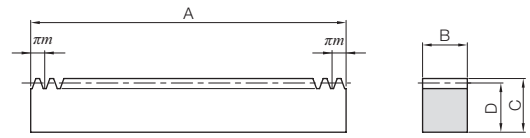

RF

\* The precision grade of J Series products is equivalent to the value shown in the table.

Catalog Number	Module	No. of teeth	Shape	Total Length				Allowable force (N)		Allowable force (kgf)	
				A	B	C	D	Bending strength	Surface durability	Bending strength	Surface durability
KRF1.5-500 KRF1.5-1000	m1.5	106	RF	499.51	15	20	18.5	3180	811	324	82.7
		212		999.03							
KRF2-500 KRF2-1000	m2	80		502.65	20	25	23	4620	1490	471	152
		160		1005.31							
KRF2.5-500 KRF2.5-1000	m2.5	64		502.65	25	30	27.5	8830	2390	901	243
		128		1005.31							
KRF3-500 KRF3-1000	m3	53		499.51	30	35	32	12700	3510	1300	358
		106	999.03								
KRF4-500 KRF4-1000	m4	40	502.65	40	45	41	22600	6460	2310	659	
		80	1005.31								
KRF5-500 KRF5-1000	m5	32	502.65	50	50	45	35300	10400	3600	1060	
		64	1005.31								

Catalog Number	Module	No. of teeth	Shape	Total Length				Mounting hole dimensions				
				A	B	C	D	E	F	G	No. of holes	Screw size
● KRFD1.5-500J ● KRFD1.5-1000J	m1.5	106	RD	499.51	15	20	18.5	8	24.76	150	4	M5
		212		999.03					49.51	180		
● KRFD2-500J ● KRFD2-1000J	m2	80		502.65	20	25	23	10	26.33	150	4	M6
		160		1005.31					52.65	180		
● KRFD2.5-500J ● KRFD2.5-1000J	m2.5	64		502.65	25	30	27.5	12	26.33	150	4	M8
		128		1005.31					52.65	180		
● KRFD3-500J ● KRFD3-1000J	m3	53		499.51	30	35	32	14	24.76	150	4	M10
		106	999.03	49.51					180	6		
● KRFD4-500J ● KRFD4-1000J	m4	40	502.65	40	45	41	18	26.33	150	4	M12	
		80	1005.31					52.65	180			6
● KRFD5-500J ● KRFD5-1000J	m5	32	502.65	50	50	45	20	31.33	220	3	M14	
		64	1005.31					62.65	5			

[Caution on J series] ① Cancellation is not possible for made-to-order products. See page 42 for lead times and allowable order quantities. See page 44 for other precautions.



J Series

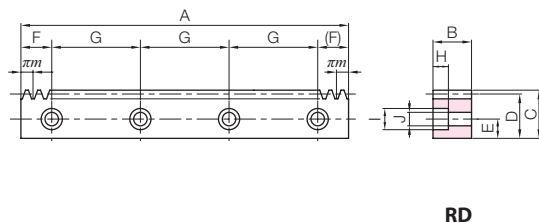

RD

Backlash (mm)	Weight (kg)	Catalog Number
0.09~0.27	1.09 2.18	<b>KRF1.5-500</b> <b>KRF1.5-1000</b>
0.11~0.30	1.82 3.63	<b>KRF2-500</b> <b>KRF2-1000</b>
0.13~0.33	2.71 5.43	<b>KRF2.5-500</b> <b>KRF2.5-1000</b>
0.14~0.37	3.76 7.53	<b>KRF3-500</b> <b>KRF3-1000</b>
0.18~0.44	6.47 12.9	<b>KRF4-500</b> <b>KRF4-1000</b>
0.20~0.49	8.88 17.8	<b>KRF5-500</b> <b>KRF5-1000</b>

Counterbore dimensions			Allowable force (N)		Allowable force (kgf)		Backlash (mm)	Weight (kg)	Catalog Number ● : J Series (Available-on-request)
H	I	J	Bending strength	Surface durability	Bending strength	Surface durability			
6	10	6	3180	811	324	82.7	0.09~0.27	1.07 2.14	● <b>KRFD1.5-500J</b> ● <b>KRFD1.5-1000J</b>
7	11	7	4620	1490	471	152	0.11~0.30	1.78 3.58	● <b>KRFD2-500J</b> ● <b>KRFD2-1000J</b>
8.6	14	9	8830	2390	901	243	0.13~0.33	2.64 5.31	● <b>KRFD2.5-500J</b> ● <b>KRFD2.5-1000J</b>
10.8	17.5	11	12700	3510	1300	358	0.14~0.37	3.63 7.32	● <b>KRFD3-500J</b> ● <b>KRFD3-1000J</b>
13	20	14	22600	6460	2310	659	0.18~0.44	6.21 12.6	● <b>KRFD4-500J</b> ● <b>KRFD4-1000J</b>
15.2	23	16	35300	10400	3600	1060	0.20~0.49	8.56 17.2	● <b>KRFD5-500J</b> ● <b>KRFD5-1000J</b>

Recommended Mating Pinions



KS Thermal Refined Spur Gears

Please see Page 100 for more details.

Spur Gears

Helical Gears

Internal Gears

Racks

CP Racks & Pinions

Miter Gears

Bevel Gears

Screw Gears

Worm Gears

Gearboxes

Other Products

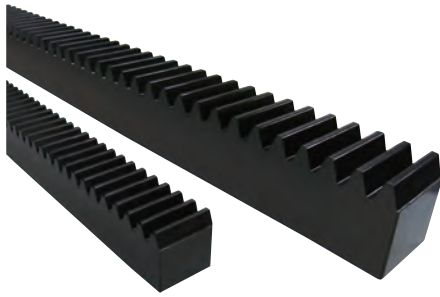

Specifications	
Precision grade	KHK R 001 Grade 4 *
Gear teeth	Standard full depth
Pressure angle	20°
Material	S45C
Heat treatment	—
Tooth hardness	(less than 210HB)
Surface treatment	Black oxide coating

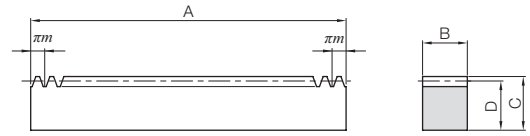

RF

\* The precision grade of J Series products is equivalent to the value shown in the table.

Catalog Number	Module	No. of teeth	Shape	Total Length	Face width	Height	Height to pitch line	Allowable force (N)		Allowable force (kgf)	
				A	B	C	D	Bending strength	Surface durability	Bending strength	Surface durability
<b>SRAF1.5-1000</b>	<b>m1.5</b>	212	RF	999.03	15	15	13.5	2160	421	220	42.9
<b>SRAF2-1000</b>	<b>m2</b>	160		1005.31	20	20	18	3830	775	391	79.0
<b>SRAF2.5-1000</b>	<b>m2.5</b>	128		1005.31	25	25	22.5	5990	1240	611	127
<b>SRAF3-1000</b>	<b>m3</b>	106		999.03	30	30	27	8620	1820	879	186
<b>SRAF4-1000</b>	<b>m4</b>	80		1005.31	40	40	36	15300	3330	1560	339
<b>SRAF1.5-2000</b>	<b>m1.5</b>	435		2049.88	17	17	15.5	2443	421	249	43
<b>SRAF2-2000</b>	<b>m2</b>	326		2048.31	20	20	18	3833	775	391	79
<b>SRAF2.5-2000</b>	<b>m2.5</b>	261		2049.88	25	25	22.5	5989	1241	611	127
<b>SRAF3-2000</b>	<b>m3</b>	217		2045.17	30	30	27	8624	1821	879	186

Catalog Number	Module	No. of teeth	Shape	Total Length	Face width	Height	Height to pitch line	Mounting hole dimensions				
				A	B	C	D	E	F	G	No. of holes	Screw size
● <b>SRAFK1.5-1000J</b>	<b>m1.5</b>	212	RA	999.03	15	15	13.5	5	49.51	180	6	M5
● <b>SRAFD2-1000J</b>	<b>m2</b>	160	RD	1005.31	20	20	18	7	52.65			M6
● <b>SRAFD2.5-1000J</b>	<b>m2.5</b>	128	RD	1005.31	25	25	22.5	9	52.65			M8
● <b>SRAFD3-1000J</b>	<b>m3</b>	106	RD	999.03	30	30	27	11	49.51			M10
● <b>SRAFD4-1000J</b>	<b>m4</b>	80	RD	1005.31	40	40	36	15	52.65			M12

[Caution on J series] ① **Cancellation is not possible** for made-to-order products. See page 42 for lead times and allowable order quantities. See page 44 for other precautions.

- Spur Gears
- Helical Gears
- Internal Gears
- Racks
- CP Racks & Pinions
- Miter Gears
- Bevel Gears
- Screw Gears
- Worm Gears
- Gearboxes
- Other Products



**J Series**

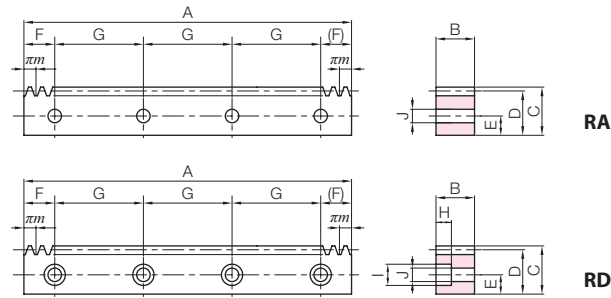

Backlash (mm)	Weight (kg)	Catalog Number
0.09~0.25	1.59	<b>SRAF1.5-1000</b>
0.11~0.28	2.84	<b>SRAF2-1000</b>
0.13~0.31	4.44	<b>SRAF2.5-1000</b>
0.14~0.35	6.35	<b>SRAF3-1000</b>
0.18~0.42	11.4	<b>SRAF4-1000</b>
0.09~0.25	4.24	<b>SRAF1.5-2000</b>
0.11~0.28	5.79	<b>SRAF2-2000</b>
0.13~0.31	9.05	<b>SRAF2.5-2000</b>
0.14~0.35	13.0	<b>SRAF3-2000</b>

Counterbore dimensions			Allowable force (N)		Allowable force (kgf)		Backlash (mm)	Weight (kg)	Catalog Number ● : J Series (Available-on-request)
H	I	J	Bending strength	Surface durability	Bending strength	Surface durability			
—	—	6	2160	421	220	42.9	0.09~0.25	1.57	● <b>SRAFK1.5-1000J</b>
7	11	7	3830	775	391	79.0	0.11~0.28	2.79	● <b>SRAFD2-1000J</b>
8.6	14	9	5990	1240	611	127	0.13~0.31	4.33	● <b>SRAFD2.5-1000J</b>
10.8	17.5	11	8620	1820	879	186	0.14~0.35	6.14	● <b>SRAFD3-1000J</b>
13	20	14	15300	3330	1560	339	0.18~0.42	11.0	● <b>SRAFD4-1000J</b>

**Recommended Mating Pinions**



**SS Spur Gears**

Please see Page 108 for more details.

Spur Gears

Helical Gears

Internal Gears

**Racks**

CP Racks & Pinions

Miter Gears

Bevel Gears

Screw Gears

Worm Gears

Gearboxes

Other Products



- Spur Gears
- Helical Gears
- Internal Gears
- Racks**
- CP Racks & Pinions
- Miter Gears
- Bevel Gears
- Screw Gears
- Worm Gears
- Gearboxes
- Other Products



Specifications	
Precision grade	KHK R 001 grade 4
Gear teeth	Standard full depth
Pressure angle	20°
Material	S45C
Heat treatment	—
Tooth hardness	(less than 210HB)
Surface treatment	Black oxide coating

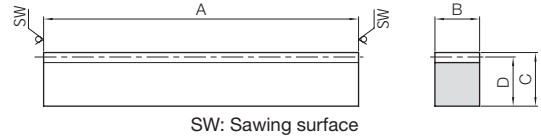

R1

Catalog Number	Module	Effective number of teeth	Shape	Total Length				Allowable force (N)		Allowable force (kgf)		Backlash (mm)	Weight (kg)
				A	B	C	D	Bending strength	Surface durability	Bending strength	Surface durability		
<b>SR0.5-100</b>	<b>m0.5</b>	62	R1	101	5	12	11.5	240	39.6	24.4	4.04	0.00~0.13	0.046
<b>SR0.8-100</b>	<b>m0.8</b>	38		101	8	12.3	11.5	613	108	62.5	11.0	0.00~0.14	0.073
<b>SR1-100</b>	<b>m1</b>	29		98	10	12	11	958	177	97.7	18.0	0.04~0.21	0.085
<b>SR1-300</b>		94		303									
<b>SR1-500</b>		159		505									
<b>SR1.5-100</b>	<b>m1.5</b>	20		101	15	20	18.5	2160	421	220	42.9	0.09~0.25	0.22
<b>SR1.5-300</b>		62		303									
<b>SR1.5-500</b>		105		505									
<b>SR2-100</b>	<b>m2</b>	14		98	20	25	23	3830	775	391	79.0	0.11~0.28	0.35
<b>SR2-300</b>		46		303									
<b>SR2-500</b>		79		505									
<b>SR2.5-100</b>	<b>m2.5</b>	11		100	25	30	27.5	5990	1240	611	127	0.13~0.31	0.54
<b>SR2.5-300</b>		37		303									
<b>SR2.5-500</b>		63		505									
<b>SR3-100</b>	<b>m3</b>	9		101	30	35	32	8620	1820	879	186	0.14~0.35	0.76
<b>SR3-300</b>		30		303									
<b>SR3-500</b>		52	505										
<b>SR4-100</b>	<b>m4</b>	6	98	40	45	41	15300	3330	1560	339	0.18~0.42	1.26	
<b>SR4-500</b>		39	505										
<b>SR5-110</b>	<b>m5</b>	5	108	50	50	45	24000	5300	2440	540	0.20~0.47	1.91	
<b>SR5-500</b>		31	505										
<b>SR6-110</b>	<b>m6</b>	4	111	60	60	54	34500	7740	3520	789	0.22~0.54	2.82	
<b>SR6-500</b>		25	505										
<b>SR8-130</b>	<b>m8</b>	3	123	75	75	67	44200	10400	4510	1060	0.28~0.63	4.85	
<b>SR10-160</b>	<b>m10</b>	3	155	90	80	70	66300	16100	6770	1640	0.33~0.70	7.67	

## Recommended Mating Pinions



## SS Spur Gears

Please see Page 108 for more details.



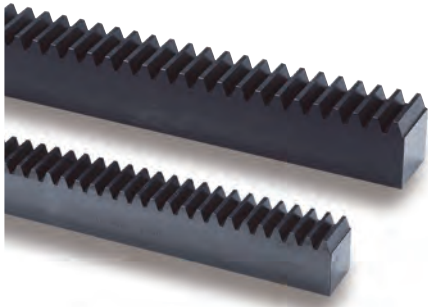

Specifications	
Precision grade	KHK R 001 grade 4
Gear teeth	Standard full depth
Pressure angle	20°
Material	S45C
Heat treatment	—
Tooth hardness	(less than 210HB)
Surface treatment	Black oxide coating

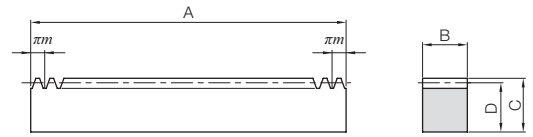

RF

Catalog Number	Module	No. of teeth	Shape	Total Length				Allowable force (N)		Allowable force (kgf)		Backlash (mm)	Weight (kg)
				A	B	C	D	Bending strength	Surface durability	Bending strength	Surface durability		
SRF0.5-300	m0.5	191	RF	300.02	5	12	11.5	240	39.6	24.4	4.04	0.00~0.13	0.14
SRF0.8-300	m0.8	119		299.08	8	12.3	11.5	613	108	62.5	11.0	0.00~0.14	0.22
SRF1-300	m1	96		301.59	10	12	11	958	177	97.7	18.0	0.04~0.21	0.26
SRF1-500		159		499.51									
SRF1-1000		318		999.03									
SRF1.5-300	m1.5	64		301.59	15	20	18.5	2160	421	220	42.9	0.09~0.25	0.66
SRF1.5-500		106		499.51									
SRF1.5-1000		212		999.03									
SRF1.5-1500		320		1507.96									
SRF1.5-2000		435		2049.88									
SRF2-300	m2	48		301.59	20	25	23	3830	775	391	79.0	0.11~0.28	1.09
SRF2-500		80		502.65									
SRF2-1000		160		1005.31									
SRF2-1500		240		1507.96									
SRF2-2000		326		2048.31									
SRF2.5-300	m2.5	38		298.45	25	30	27.5	5990	1240	611	127	0.13~0.31	1.61
SRF2.5-500		64		502.65									
SRF2.5-1000		128		1005.31									
SRF2.5-1500		192		1507.96									
SRF2.5-2000		261		2049.88									
SRF3-300	m3	32	301.59	30	35	32	8620	1820	879	186	0.14~0.35	2.27	
SRF3-500		53	499.51										
SRF3-1000		106	999.03										
SRF3-1500		160	1507.96										
SRF3-2000		217	2045.17										
SRF4-500	m4	40	502.65	40	45	41	15300	3330	1560	339	0.18~0.42	6.47	
SRF4-1000		80	1005.31										
SRF4-1500		120	1507.96										
SRF4-2000		163	2048.31										
SRF5-500	m5	32	502.65	50	50	45	24000	5300	2440	540	0.20~0.47	8.88	
SRF5-1000		64	1005.31										
SRF5-1500		96	1507.96										
SRF5-2000		130	2042.04										
SRF6-500	m6	26	490.09	60	60	54	34500	7740	3520	789	0.22~0.54	12.5	
SRF6-1000		53	999.03										
SRF6-1500		80	1507.96										
SRF6-2000		108	2035.75										
SRF8-500	m8	20	502.66	75	75	67	44200	10400	4510	1060	0.28~0.63	19.8	
SRF8-1000		40	1005.31										
SRF10-1000	m10	32	1005.31	90	80	70	66300	16100	6770	1640	0.33~0.70	49.7	

Spur Gears

Helical Gears

Internal Gears

Racks

CP Racks & Pinions

Miter Gears

Bevel Gears

Screw Gears

Worm Gears

Gearboxes

Other Products





Specifications	
Precision grade	KHK R 001 Grade 4 *
Gear teeth	Standard full depth
Pressure angle	20°
Material	S45C
Heat treatment	—
Tooth hardness	(less than 210HB)
Surface treatment	Black oxide coating

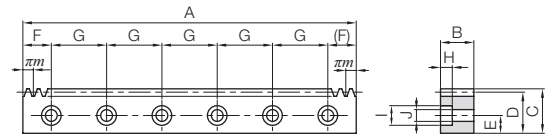

\* The precision grade of J Series products is equivalent to the value shown in the table.

RD

Catalog Number ● : J Series (Available-on-request)	Module	No. of teeth	Shape	Total Length	Face width	Height	Height to pitch line	Mounting hole dimensions				
				A	B	C	D	E	F	G	No. of holes	Screw size
●SRFK0.5-300J	<b>m0.5</b>	191	RA	300.02	5	12	11.5	5.5	15.01	90	4	M3
●SRFK0.8-300J	<b>m0.8</b>	119		299.08	8	12.3	11.5	5.5	14.54	90	4	M4
●SRFK1-300J	<b>m1</b>	96		301.59	10	12	11	5	20.80	130	3	M4
●SRFK1-500J		159		499.51					24.76	150	4	
●SRFD1.5-300J	<b>m1.5</b>	64	RD	301.59	15	20	18.5	8	20.80	130	3	M5
●SRFD1.5-500J		106		499.51					24.76	150	4	
SRFD1.5-1000		212		999.03					49.51	180	6	
SRFD1.5-1500		320		1507.96					33.98	180	9	
SRFD1.5-2000		435		2049.88					34.94	180	12	
●SRFD2-300J	<b>m2</b>	48		301.59	20	25	23	10	20.80	130	3	M6
●SRFD2-500J		80		502.65					26.33	150	4	
SRFD2-1000		160		1005.31					52.65	180	6	
SRFD2-1500		240		1507.96					33.98	180	9	
SRFD2-2000		326		2048.31					34.15	180	12	
●SRFD2.5-300J	<b>m2.5</b>	38	298.45	25	30	27.5	12	19.23	130	3	M8	
●SRFD2.5-500J		64	502.65					26.33	150	4		
SRFD2.5-1000		128	1005.31					52.65	180	6		
SRFD2.5-1500		192	1507.96					33.98	180	9		
SRFD2.5-2000		261	2049.88					34.94	180	12		
●SRFD3-300J	<b>m3</b>	32	301.59	30	35	32	14	20.80	130	3	M10	
●SRFD3-500J		53	499.51					24.76	150	4		
SRFD3-1000		106	999.03					49.51	180	6		
SRFD3-1500		160	1507.96					33.98	180	9		
SRFD3-2000		217	2045.17					32.58	180	12		
●SRFD4-500J	<b>m4</b>	40	502.65	40	45	41	18	26.33	150	4	M12	
SRFD4-1000		80	1005.31					52.65	180	6		
SRFD4-1500		120	1507.96					33.98	180	9		
SRFD4-2000		163	2048.31					34.15	180	12		
●SRFD5-500J	<b>m5</b>	32	502.65	50	50	45	20	31.33	220	3	M14	
SRFD5-1000		64	1005.31					62.65	220	5		
SRFD5-1500		96	1507.96					93.98	220	7		
SRFD5-2000		130	2042.04					31.02	220	10		
●SRFD6-500J	<b>m6</b>	26	490.09	60	60	54	23	25.04	220	3	M16	
SRFD6-1000		53	999.03					59.51	220	5		
SRFD6-1500		80	1507.96					93.98	220	7		
SRFD6-2000		108	2035.75					27.88	220	10		

[Caution on Secondary Operations] ① Avoid hardening racks with bolt holes, due to mounting hole deformation.

[Caution on J series] ① **Cancellation is not possible** for made-to-order products. See page 42 for lead times and allowable order quantities. See page 44 for other precautions.

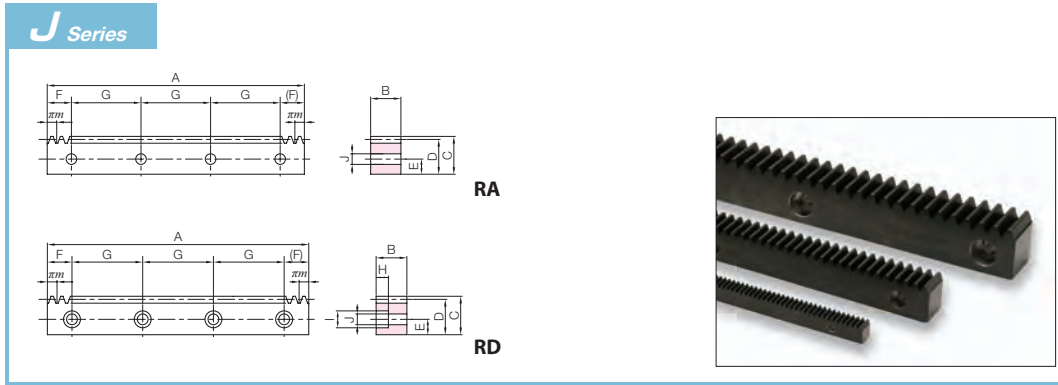

Counterbore dimensions			Allowable force (N)		Allowable force (kgf)		Backlash (mm)	Weight (kg)	Catalog Number ● : J Series (Available-on-request)
H	I	J	Bending strength	Surface durability	Bending strength	Surface durability			
—	—	3.4	240	39.6	24.4	4.04	0.00~0.13	0.13	●SRFK0.5-300J
—	—	4.5	613	108	62.5	11.0	0.00~0.14	0.21	●SRFK0.8-300J
—	—	4.5	958	177	97.7	18.0	0.04~0.21	0.26 0.43	●SRFK1-300J ●SRFK1-500J
6	10	6	2160	421	220	42.9	0.09~0.25	0.64 1.07 2.14 3.23 4.40	●SRFD1.5-300J ●SRFD1.5-500J SRFD1.5-1000 SRFD1.5-1500 SRFD1.5-2000
7	11	7	3830	775	391	79.0	0.11~0.28	1.06 1.78 3.58 5.36 7.29	●SRFD2-300J ●SRFD2-500J SRFD2-1000 SRFD2-1500 SRFD2-2000
8.6	14	9	5990	1240	611	127	0.13~0.31	1.55 2.64 5.31 7.97 10.8	●SRFD2.5-300J ●SRFD2.5-500J SRFD2.5-1000 SRFD2.5-1500 SRFD2.5-2000
10.8	17.5	11	8620	1820	879	186	0.14~0.35	2.17 3.63 7.32 11.1 15.0	●SRFD3-300J ●SRFD3-500J SRFD3-1000 SRFD3-1500 SRFD3-2000
13	20	14	15300	3330	1560	339	0.18~0.42	6.21 12.6 18.8 25.6	●SRFD4-500J SRFD4-1000 SRFD4-1500 SRFD4-2000
15.2	23	16	24000	5300	2440	540	0.20~0.47	8.56 17.2 25.9 35.0	●SRFD5-500J SRFD5-1000 SRFD5-1500 SRFD5-2000
17.5	26	18	34500	7740	3520	789	0.22~0.54	12.0 24.6 37.2 50.2	●SRFD6-500J SRFD6-1000 SRFD6-1500 SRFD6-2000

## Recommended Mating Pinions



### SS Spur Gears

Please see Page 104 for more details.



Spur Gears  
 Helical Gears  
 Internal Gears  
**Racks**  
 CP Racks & Pinions  
 Miter Gears  
 Bevel Gears  
 Screw Gears  
 Worm Gears  
 Gearboxes  
 Other Products



Specifications	
Precision grade	KHK R 001 grade 5
Gear teeth	Standard full depth
Pressure angle	20°
Material	SUS304
Heat treatment	Solution treated
Tooth hardness	(less than 187HB)

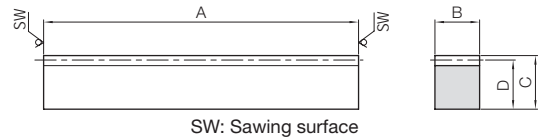

R1

Catalog Number	Module	Effective number of teeth	Shape	Total Length	Face width	Height	Height to pitch line	Allowable force (N)		Allowable force (kgf)	
				A	B	C	D	Bending strength	Surface durability	Bending strength	Surface durability
<b>SUR1-500</b>	<b>m1</b>	159	R1	505	10	12	11	457	99.4	46.6	10.1
<b>SUR1.5-500</b>	<b>m1.5</b>	105			15	20	18.5	1030	237	105	24.2
<b>SUR2-500</b>	<b>m2</b>	79			20	25	23	1830	436	187	44.5
<b>SUR2.5-500</b>	<b>m2.5</b>	63			25	30	27.5	2860	698	292	71.2
<b>SUR3-500</b>	<b>m3</b>	52			30	35	32	4120	1030	420	105
<b>SUR4-500</b>	<b>m4</b>	39			40	45	41	7320	1870	746	191

Catalog Number	Module	No. of teeth	Shape	Total Length	Face width	Height	Height to pitch line	Allowable force (N)		Allowable force (kgf)	
				A	B	C	D	Bending strength	Surface durability	Bending strength	Surface durability
<b>SURF1.5-1000</b>	<b>m1.5</b>	212	RF	999.03	15	20	18.5	1030	237	105	24.2
<b>SURF2-1000</b>	<b>m2</b>	160		1005.31	20	25	23	1830	436	187	44.5
<b>SURF2.5-1000</b>	<b>m2.5</b>	128		1005.31	25	30	27.5	2860	698	292	71.2
<b>SURF3-1000</b>	<b>m3</b>	106		999.03	30	35	32	4120	1030	420	105
<b>SURF4-1000</b>	<b>m4</b>	80		1005.31	40	45	41	7320	1870	746	191

Catalog Number	Module	No. of teeth	Shape	Total Length	Face width	Height	Height to pitch line	Mounting hole dimensions					
				A	B	C	D	E	F	G	No. of holes	Screw size	
<b>SURFD1.5-1000</b>	<b>m1.5</b>	212	RD	999.03	15	20	18.5	8	49.51	180	6		M5
<b>SURFD2-1000</b>	<b>m2</b>	160		1005.31	20	25	23	10	52.65				M6
<b>SURFD2.5-1000</b>	<b>m2.5</b>	128		1005.31	25	30	27.5	12	52.65				M8
<b>SURFD3-1000</b>	<b>m3</b>	106		999.03	30	35	32	14	49.51				M10
<b>SURFD4-1000</b>	<b>m4</b>	80		1005.31	40	45	41	18	52.65				M12

[Caution on Product Characteristics] ① The stainless steel material is given \*solution treatment and \*\*passivation. Passivation improves the anti-rust performance, but it is not effective on the processed surface of the product. Note that this product is not completely rustproof.

\* Solution treatment  
 Heat treatment by melting the carbide generated on the surface into the material when manufacturing the material

\*\* Passivation  
 Pickled (nitric hydrofluoric acid) to make it more rust resistant



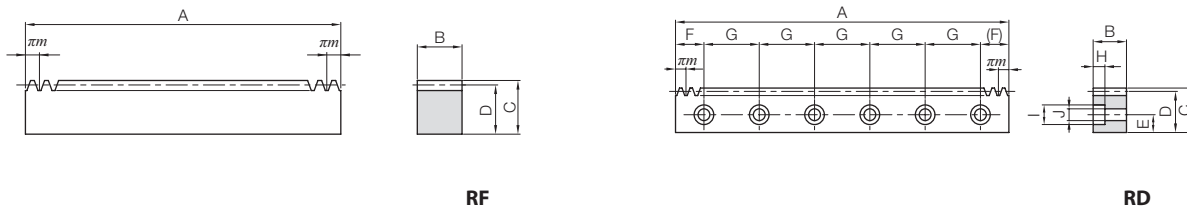

Backlash (mm)	Weight (kg)	Catalog Number
0.04~0.23	0.44	<b>SUR1-500</b>
0.09~0.27	1.11	<b>SUR1.5-500</b>
0.11~0.30	1.84	<b>SUR2-500</b>
0.13~0.33	2.75	<b>SUR2.5-500</b>
0.14~0.37	3.84	<b>SUR3-500</b>
0.18~0.44	6.57	<b>SUR4-500</b>

Backlash (mm)	Weight (kg)	Catalog Number
0.09~0.27	2.20	<b>SURF1.5-1000</b>
0.11~0.30	3.67	<b>SURF2-1000</b>
0.13~0.33	5.48	<b>SURF2.5-1000</b>
0.14~0.37	7.61	<b>SURF3-1000</b>
0.18~0.44	13.1	<b>SURF4-1000</b>

Counterbore dimensions			Allowable force (N)		Allowable force (kgf)		Backlash (mm)	Weight (kg)	Catalog Number
H	I	J	Bending strength	Surface durability	Bending strength	Surface durability			
6	10	6	1030	237	105	24.2	0.09~0.27	2.16	<b>SURFD1.5-1000</b> <b>SURFD2-1000</b> <b>SURFD2.5-1000</b> <b>SURFD3-1000</b> <b>SURFD4-1000</b>
7	11	7	1830	436	187	44.5	0.11~0.30	3.61	
8.6	14	9	2860	698	292	71.2	0.13~0.33	5.37	
10.8	17.5	11	4120	1030	420	105	0.14~0.37	7.40	
13	20	14	7320	1870	746	191	0.18~0.44	12.7	

## Recommended Mating Pinions



## SUS/SUSA Stainless Steel Spur Gears

Please see Page 156 for more details.

Spur Gears

Helical Gears

Internal Gears

Racks

CP Racks & Pinions

Miter Gears

Bevel Gears

Screw Gears

Worm Gears

Gearboxes

Other Products

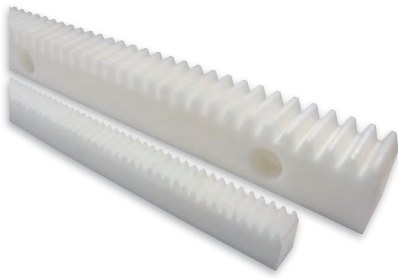

Specifications	
Precision grade	KHK R 001 Grade 5 *
Gear teeth	Standard full depth
Pressure angle	20°
Material	Polyacetal
Heat treatment	—
Tooth hardness	(115 to 120HRR)

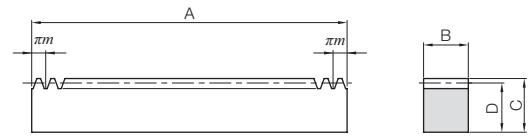

RF

\* The precision grade is equivalent to the value shown in the table.

Catalog Number	Module	No. of teeth	Shape	Total Length	Face width	Height	Height to pitch line	Allowable force (N)	Allowable force (kgf)	Backlash (mm)	Weight (kg)
				A	B	C	D	Bending strength	Bending strength		
<b>DRF1-500</b>	<b>m1</b>	159	RF	499.51	10	12	11	80.7	8.23	0.15~0.36	0.077
<b>DRF1.5-1000</b>	<b>m1.5</b>	212		999.03	15	20	18.5	182	18.5	0.18~0.39	0.39
<b>DRF2-1000</b>	<b>m2</b>	160		1005.31	20	25	23	323	32.9	0.21~0.42	0.65
<b>DRF2.5-1000</b>	<b>m2.5</b>	128		1005.31	25	30	27.5	504	51.4	0.23~0.46	0.98
<b>DRF3-1000</b>	<b>m3</b>	106		999.03	30	35	32	726	74.1	0.28~0.52	1.35

Catalog Number	Module	No. of teeth	Shape	Total Length	Face width	Height	Height to pitch line	Mounting hole dimensions				
				A	B	C	D	E	F	G	No. of holes	Screw size
● <b>DRFK1-500J</b>	<b>m1</b>	159	RA	499.51	10	12	11	5	24.76	150	4	M4
● <b>DRFD1.5-1000J</b>	<b>m1.5</b>	212	RD	999.03	15	20	18.5	8	49.51	180	6	M5
● <b>DRFD2-1000J</b>	<b>m2</b>	160		1005.31	20	25	23	10	52.65	180	6	M6
● <b>DRFD2.5-1000J</b>	<b>m2.5</b>	128		1005.31	25	30	27.5	12	52.65	180	6	M8
● <b>DRFD3-1000J</b>	<b>m3</b>	106		999.03	30	35	32	14	49.51	180	6	M10

[Caution on Product Characteristics] ① Boiling sterilization is not required when using this product in food machines. Note that POM plastic complies with the Food Sanitation Law of the US Food and Drug Administration (FDA), and boiling or exposing it to steam will cause the material to be damaged.

[Caution on J series] ① **Cancellation is not possible** for made-to-order products. See page 42 for lead times and allowable order quantities. See page 44 for other precautions.



J Series

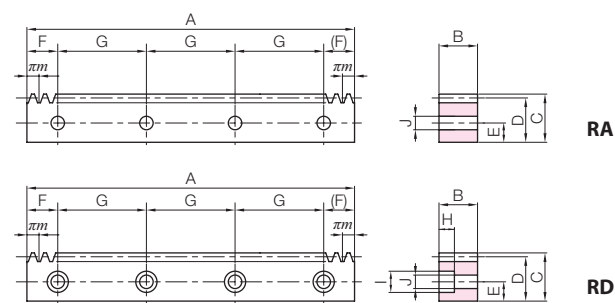

Counterbore dimensions			Allowable force (N) Bending strength	Allowable force (kgf) Bending strength	Backlash (mm)	Weight (kg)	Catalog Number ● : J Series (Available-on-request)
H	I	J					
—	—	4.5	80.7	8.23	0.15~0.36	0.077	●DRFK1-500J
6	10	6	182	18.5	0.18~0.39	0.38	●DRFD1.5-1000J
7	11	7	323	32.9	0.21~0.42	0.64	●DRFD2-1000J
8.6	14	9	504	51.4	0.23~0.46	0.95	●DRFD2.5-1000J
10.8	17.5	11	726	74.1	0.28~0.52	1.31	●DRFD3-1000J

Recommended Mating Pinions



SUS/SUSA Stainless Steel Spur Gears

Please see Page 156 for more details.

Spur Gears

Helical Gears

Internal Gears

Racks

CP Racks & Pinions

Miter Gears

Bevel Gears

Screw Gears

Worm Gears

Gearboxes

Other Products



Spur Gears  
Helical Gears  
Internal Gears  
Racks  
CP Racks & Pinions  
Miter Gears  
Bevel Gears  
Screw Gears  
Worm Gears  
Gearboxes  
Other Products

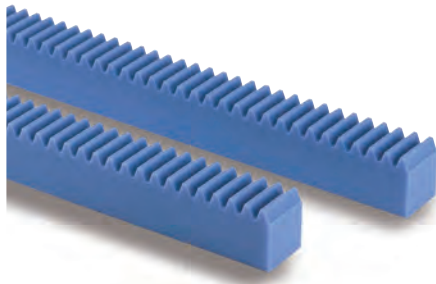

Specifications	
Precision grade	KHK R 001 Grade 5 *
Gear teeth	Standard full depth
Pressure angle	20°
Material	MC901
Heat treatment	—
Tooth hardness	(115 to 120HRR)

\* The precision grade is equivalent to the value shown in the table.

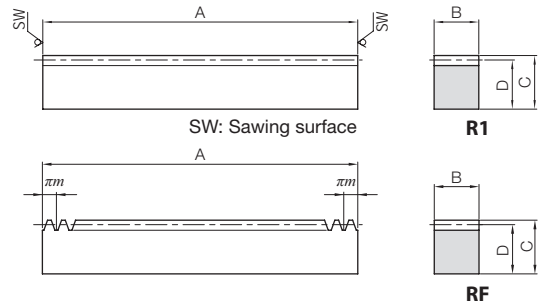

Catalog Number	Module	Effective number of teeth	Shape	Total Length	Face width	Height	Height to pitch line	Allowable force (N)	Allowable force (kgf)	Backlash (mm)	Weight (kg)
				A	B	C	D	Bending strength	Bending strength		
<b>PR1-500</b>	<b>m1</b>	159	R1	505	10	12	11	92.8	9.46	0.18~0.39	0.064
<b>PR1.5-500</b>	<b>m1.5</b>	105			15	20	18.5	209	21.3	0.21~0.42	0.16
<b>PR2-500</b>	<b>m2</b>	79			20	25	23	371	37.9	0.24~0.45	0.27
<b>PR2.5-500</b>	<b>m2.5</b>	63			25	30	27.5	580	59.2	0.26~0.49	0.40
<b>PR3-500</b>	<b>m3</b>	52			30	35	32	835	85.2	0.32~0.56	0.56

Catalog Number	Module	No. of teeth	Shape	Total Length	Face width	Height	Height to pitch line	Allowable force (N)	Allowable force (kgf)	Backlash (mm)	Weight (kg)
				A	B	C	D	Bending strength	Bending strength		
<b>PRF1.5-1000</b>	<b>m1.5</b>	212	RF	999.03	15	20	18.5	209	21.3	0.21~0.42	0.32
<b>PRF2-1000</b>	<b>m2</b>	160		1005.31	20	25	23	371	37.9	0.24~0.45	0.54
<b>PRF2.5-1000</b>	<b>m2.5</b>	128		1005.31	25	30	27.5	580	59.2	0.26~0.49	0.80
<b>PRF3-1000</b>	<b>m3</b>	106		999.03	30	35	32	835	85.2	0.32~0.56	1.11

[Caution on Product Characteristics] ① These plastic racks expand and contract depending on the temperature and humidity. The length per 1m changes by 0.45 mm when the temperature changes by 10°C, and about 5 mm with water absorption of 2%. The bending is 5 mm or less per 1 m, but may exceed 5 mm over time in products with total length 1000 mm. Mount for use while correcting along the gear cutting reference surface (bottom).

## Recommended Mating Pinions



### SUS/SUSA Stainless Steel Spur Gears

Please see Page 156 for more details.



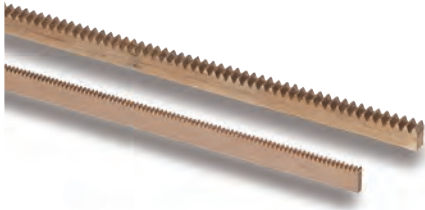

Specifications	
Precision grade	KHK R 001 grade 4
Gear teeth	Standard full depth
Pressure angle	20°
Material	Free cutting brass (C3604)
Heat Treatment	—
Tooth hardness	(80HV or more)

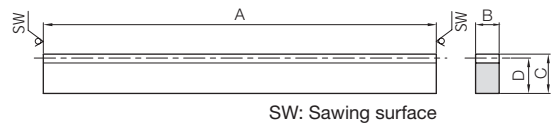

R1

Catalog Number	Module	Effective number of teeth	Shape	Total Length	Face width	Height	Height to pitch line	Allowable force (N)		Allowable force (kgf)		Backlash (mm)	Weight (kg)
				A	B	C	D	Bending strength	Surface durability	Bending strength	Surface durability		
<b>BSR0.5-300</b>	<b>m0.5</b>	190	R1	303	3	9	8.5	28.7	—	2.93	—	0.00~0.13	0.066
<b>BSR0.8-300</b>	<b>m0.8</b>	118			4	10	9.2	61.3	—	6.25	—	0.00~0.14	0.095
<b>BSR1-300</b>	<b>m1</b>	94			6	10	9	115	—	11.7	—	0.04~0.21	0.14

## Recommended Mating Pinions



### BSS Spur Gears

Please see Page 188 for more details.





## Round Racks



Specifications	
Precision grade	KHK R 001 grade 4
Gear teeth	Standard full depth
Pressure angle	20°
Material	S45C
Heat treatment	—
Tooth hardness	(less than 210HB)
Surface treatment	Black oxide coating

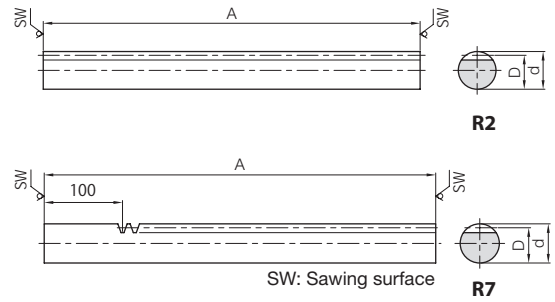

Catalog Number	Module	Effective number of teeth	Shape	Total Length	Outside dia.	Height to pitch line	Allowable force (N)		Allowable force (kgf)		Backlash (mm)	Weight (kg)
				A	d <sub>H9</sub>	D	Bending strength	Surface durability	Bending strength	Surface durability		
<b>SRO1-500</b>	<b>m1</b>	159	R2	505	10	9	800	121	81.6	12.3	0.04~0.21	0.29
<b>SRO1.5-500</b>	<b>m1.5</b>	105		505	15	13.5	1800	288	184	29.3	0.09~0.25	0.65
<b>SRO2-500</b>	<b>m2</b>	79		505	20	18	3200	530	326	54.0	0.11~0.28	1.16
<b>SRO2-1000</b>		159		1010	20	18	3200	530	326	54.0	0.11~0.28	2.31
<b>SRO2.5-500</b>	<b>m2.5</b>	63		505	25	22.5	5000	848	510	86.5	0.13~0.31	1.81
<b>SRO2.5-1000</b>		127		1010	25	22.5	5000	848	510	86.5	0.13~0.31	3.61
<b>SRO3-500</b>	<b>m3</b>	52		505	30	27	7200	1240	735	127	0.14~0.35	2.60
<b>SRO3-1000</b>		105		1010	30	27	7200	1240	735	127	0.14~0.35	5.20
<b>SRO4-500</b>	<b>m4</b>	39		505	40	36	12800	2270	1310	232	0.18~0.42	4.62
<b>SRO4-1000</b>		79		1010	40	36	12800	2270	1310	232	0.18~0.42	9.24
<b>SRO5-1000</b>	<b>m5</b>	63	1010	50	45	20000	3620	2040	369	0.20~0.47	14.4	

Catalog Number	Module	Effective number of teeth	Shape	Total Length	Outside dia.	Height to pitch line	Allowable force (N)		Allowable force (kgf)		Backlash (mm)	Weight (kg)
				A	d <sub>H9</sub>	D	Bending strength	Surface durability	Bending strength	Surface durability		
<b>SROS1-500</b>	<b>m1</b>	128	R7	505	10	9	800	121	81.6	12.3	0.04~0.21	0.29
<b>SROS1.5-500</b>	<b>m1.5</b>	85			15	13.5	1800	288	184	29.3	0.09~0.25	0.66
<b>SROS2-500</b>	<b>m2</b>	64			20	18	3200	530	326	54.0	0.11~0.28	1.17
<b>SROS2.5-500</b>	<b>m2.5</b>	51			25	22.5	5000	848	510	86.5	0.13~0.31	1.83
<b>SROS3-500</b>	<b>m3</b>	42			30	27	7200	1240	735	127	0.14~0.35	2.64

[Caution on Product Characteristics] ① Because this is extruded material, the outer diameter may be out of H9 tolerance in sections.

[Caution on Secondary Operations] ① Avoid hardening round racks, due to twisting and deformation occurring and the difficulty of straightening the rack after hardening.

## Recommended Mating Pinions



### SS Spur Gears

Please see Page 108 for more details.





Specifications	
Precision grade	KHK R 001 grade 5
Gear teeth	Standard full depth
Pressure angle	20°
Material	SUS303
Heat treatment	—
Tooth hardness	(less than 187HB)

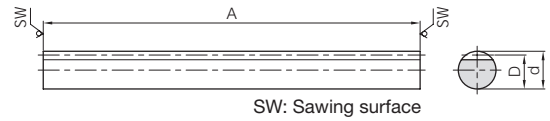

R2

Catalog Number	Module	Effective number of teeth	Shape	Total Length	Outside dia.	Height to pitch line	Allowable force (N)		Allowable force (kgf)		Backlash (mm)	Weight (kg)
				A	d <sub>h9</sub>	D	Bending strength	Surface durability	Bending strength	Surface durability		
<b>SURO1-500</b>	<b>m1</b>	159	R2	505	10	9	382	67.9	39.0	6.93	0.04~0.23	0.29
<b>SURO1.5-500</b>	<b>m1.5</b>	105		505	15	13.5	859	162	87.6	16.5	0.09~0.27	0.66
<b>SURO2-500</b>	<b>m2</b>	79		505	20	18	1530	298	156	30.4	0.11~0.30	1.17
<b>SURO2-1000</b>		159		1010								2.33
<b>SURO2.5-500</b>	<b>m2.5</b>	63		505	25	22.5	2390	477	243	48.7	0.13~0.33	1.82
<b>SURO2.5-1000</b>		127		1010								3.65
<b>SURO3-500</b>	<b>m3</b>	52		505	30	27	3440	700	351	71.4	0.14~0.37	2.63
<b>SURO3-1000</b>		105		1010								5.25

[Caution on Product Characteristics] ① Because this is extruded material, the outer diameter may be out of H9 tolerance in sections.

## Recommended Mating Pinions

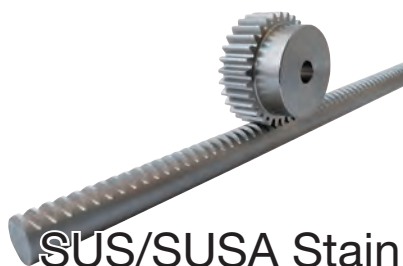

### SUS/SUSA Stainless Steel Spur Gears

Please see Page 156 for more details.





# Molded Flexible Racks



Specifications	
Precision grade	KHK R 001 grade 8
Gear teeth	Standard full depth
Pressure angle	20°
Material	Duracon (R) (M25-44)
Heat treatment	—
Tooth hardness	(110 to 120HRR)

\* "Duracon (R)" is a registered trademark of Polyplastics Co., Ltd. in Japan as well as other countries.

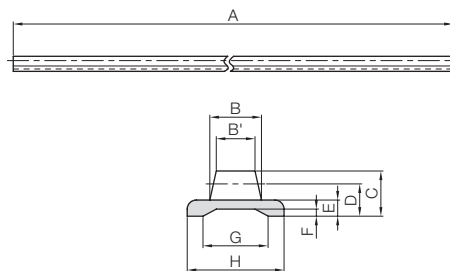

R4

Catalog Number	Module	Shape	Total Length	Face width	Face width	Height	Height to pitch line	Base thickness	Base groove depth	Base groove width	Base width
			A	B	B'	C	D	E	F	G	H
<b>DR0.8-2000</b>	<b>m0.8</b>	R4	2000	3.8	3	3.3	2.5	1.5	0.7	3.7	8
<b>DR1-2000</b>	<b>m1</b>			5	4	4.3	3.3	2	0.9	4.9	10
<b>DR1.5-2000</b>	<b>m1.5</b>			6.5	5	5.7	4.2	2.3	1	8	12
<b>DR2-2000</b>	<b>m2</b>			8	6	7	5	2.5	1.1	10.1	15

- [Caution on Product Characteristics]
- When using the DR flexible rack in an arc, the minimum bending radius (R) is 150 mm for both the external and internal teeth. Reducing the radius increase the pitch errors and tooth profile errors which prevent the teeth from meshing at the normal center distance, so be sure to make adjustments before use.
  - It cannot be used where positioning accuracy is required.
  - For the dimensional accuracy of each part, see the dimensional tolerance of molded items in the separate table.

## DR dedicated SRS Rack Clamps

Note that products with an asterisk (\*) after the catalog number will no longer be manufactured after 20 June, 2026.

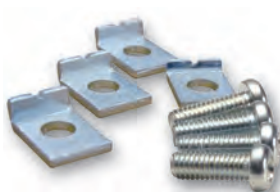

Installation image

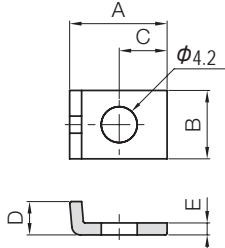

Material: SPCC trivalent chromate finish

Catalog Number	Shape	A	B	C	D	E	F	Weight (g)
<b>SRS-1*</b>	T7	10.2	8	4.5	2.7	1.2	—	2.24
<b>SRS-2*</b>		11.4		5.6	3.9	1.4		2.52

- [Caution on Product Characteristics]
- M4 x 12 pan head machine screws with cross holes are included.
  - The set includes a rack clamp and 10 machine screws.

Dimensional tolerance of DR / molded item (unit: mm)

Dimensional classification	Grade	Rough grade
	3 or less	
4 to 6		±0.25
7 to 10		±0.30
11 to 18		±0.35
19 to 30		±0.40
Over 30		±0.50

SRS/ARL / Normal dimensional tolerance of bending and drawing (unit: mm)

Dimensional classification	Grade	Grade B
	6 or less	
7 to 30		±0.50
31 to 120		±0.80
120 to 400		±1.20
400 to 1000		±2.00
1000 to 2000		±3.00



# DR Pinions



Specifications	
Precision grade	JIS grade N8 (JIS B1702-1: 1998)*
Gear teeth	Standard full depth
Pressure angle	20°
Material	S45C
Heat treatment	—
Tooth hardness	(less than 194HB)
Surface treatment	Black oxide coating

\* The precision grade of products with a module of less than 0.8 is equivalent to the value shown in the table.

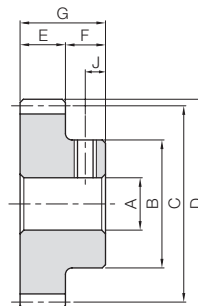

S1T

Catalog Number	Module	No. of teeth	Shape	Bore	Hub dia.	Pitch dia.	Outside dia.	Face width	Hub width	Total length	Socket head screw	
				A <sub>H7</sub>	B	C	D	E	F	G	Size	J
<b>SSDR0.8-35</b>	<b>m0.8</b>	35	S1T	5	16	28	29.6	3	7	10	M4	3.5
<b>SSDR1-30</b>	<b>m1</b>	30		6	20	30	32	4	8	12	M4	4
<b>SSDR1.5-20</b>	<b>m1.5</b>	20		6	20	30	33	5	10	15	M4	5
<b>SSDR2-15</b>	<b>m2</b>	15		8	22	30	34	6	10	16	M5	5

List of Products for DR Molded Flexible Racks

Molded Flexible Racks	Rack Clamps	Slide Rails	Dedicated Pinions
<b>DR0.8-2000</b>	<b>SRS-1</b>	<b>ARL-0.8</b>	<b>SSDR0.8-35</b>
<b>DR1-2000</b>	<b>SRS-1</b>	<b>ARL-1</b>	<b>SSDR1-30</b>
<b>DR1.5-2000</b>	<b>SRS-2</b>	<b>ARL-1.5</b>	<b>SSDR1.5-20</b>
<b>DR2-2000</b>	<b>SRS-2</b>	<b>ARL-2</b>	<b>SSDR2-15</b>

Allowable force (N)	Allowable force (kgf)	Weight (kg)	Catalog Number
Bending strength	Bending strength		
112	11.4	0.036	<b>DR0.8-2000</b>
161	16.4	0.060	<b>DR1-2000</b>
161	16.5	0.085	<b>DR1.5-2000</b>
265	27.0	0.12	<b>DR2-2000</b>

\* Molded flexible racks of 2 meters or longer are also available by request as custom-made products.  
(Only the length can be changed, up to 50 m)

DR dedicated **ARL**  
Slide Rails

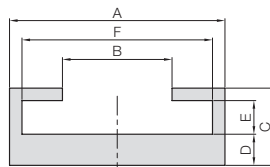

T6

Material: Aluminum (A6063S-T5) Overall length: 1,000 mm

Catalog Number	Shape	A	B	C	D	E	F	Weight (kg)
<b>ARL-0.8</b>	T6	10.3	4.4	4.7	2	1.7	8.3	0.081
<b>ARL-1</b>		12.3	5.6	5.2	2	2.2	10.3	0.096
<b>ARL-1.5</b>		14.3	7.2	5.5	2	2.5	12.3	0.11
<b>ARL-2</b>		17.3	8.8	6.2	2.5	2.7	15.3	0.15

Steel Spur Gears

Allowable torque (N-m)	Allowable torque (kgf-m)	Weight (g)	Catalog Number
Bending strength	Bending strength		
2.59	0.26	23.5	<b>SSDR0.8-35</b>
4.46	0.45	38.6	<b>SSDR1-30</b>
7.35	0.75	48.4	<b>SSDR1.5-20</b>
10.4	1.06	56.1	<b>SSDR2-15</b>

Applications for DR Molded Flexible Racks

As it is possible to fix the position of the pinion and bend the DR molded flexible racks into any shape, they can be used for special purposes.

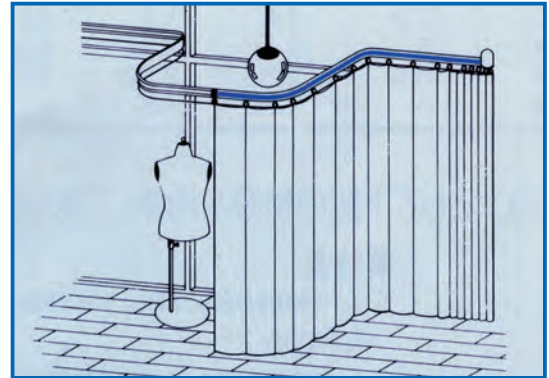

Electric curtain

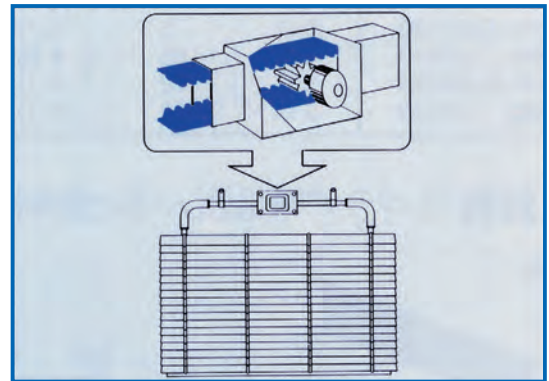

Electric blinds

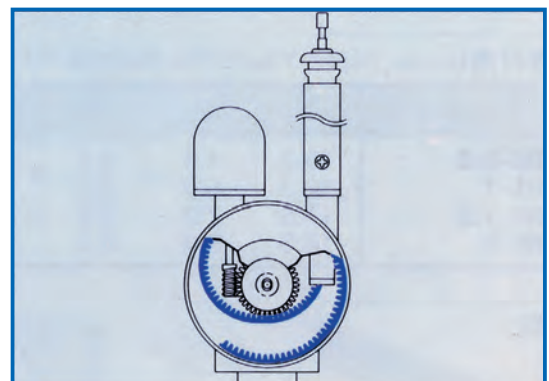

Electric antenna

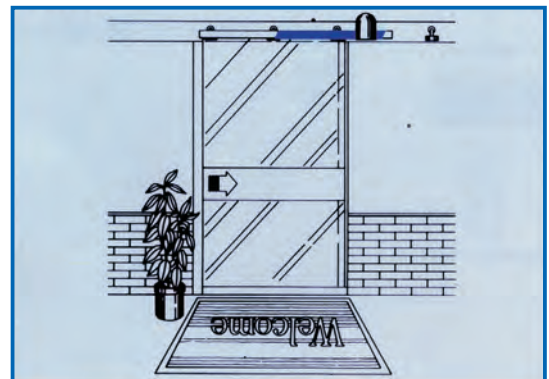

Automatic doors

Spur Gears

Helical Gears

Internal Gears

Racks

CP Racks & Pinions

Miter Gears

Bevel Gears

Screw Gears

Worm Gears

Gearboxes

Other Products



Specifications	
Precision grade	KHK R 001 Grade 1 *
Reference section of gear	Rotating plane
Gear teeth	Standard full depth
Transverse pressure angle	20°
Helix angle	21°30'
Material	SCM440
Heat treatment	Thermal refining only
Tooth hardness	225 to 352HB

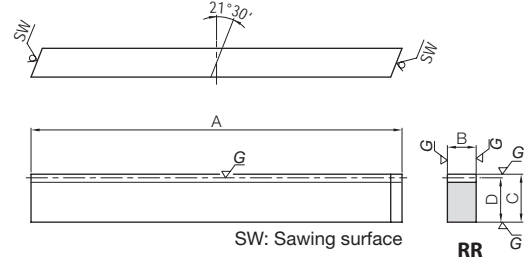

\* The precision grade of J Series products is equivalent to the value shown in the table.

Catalog Number	Module	Effective number of teeth	Direction of spiral	Shape	Total Length		Face width	Height	Height to pitch line	Allowable force (N)		Allowable force (kgf)	
					A	B				C	D	Bending strength	Surface durability
KRHG1-100R KRHG1-100L	m1	28	R L	RR RL	98	8	15	14	1180	966	121	98.5	
KRHG1.5-100R KRHG1.5-100L	m1.5	19	R L	RR RL	101	12	20	18.5	2670	2180	272	222	
KRHG2-100R (Made to Order) KRHG2-100L (Made to Order)	m2	13	R L	RR RL	98	16	25	23	4740	3880	483	396	
KRHG2.5-100R (Made to Order) KRHG2.5-100L (Made to Order)	m2.5	10	R L	RR RL	100	20	30	27.5	7400	6070	755	619	
KRHG3-100R (Made to Order) KRHG3-100L (Made to Order)	m3	8	R L	RR RL	102	25	35	32	11100	9030	1130	921	

Catalog Number	Module	No. of teeth	Direction of spiral	Shape	Total Length		Face width	Height	Height to pitch line	Allowable force (N)		Allowable force (kgf)	
					A	A'				B	C	D	Bending strength
KRHGF1-500R KRHGF1-500L	m1	159	R L	RFR RFL	499.51	502.66	8	15	14	1180	966	121	98.5
KRHGF1.5-500R KRHGF1.5-500L	m1.5	106	R L	RFR RFL	499.51	504.23	12	20	18.5	2670	2180	272	222
KRHGF2-1000R KRHGF2-1000L	m2	160	R L	RFR RFL	1005.31	1011.61	16	25	23	4740	3880	483	396
KRHGF2.5-1000R KRHGF2.5-1000L	m2.5	128	R L	RFR RFL	1005.31	1013.19	20	30	27.5	7400	6070	755	619
KRHGF3-1000R KRHGF3-1000L	m3	106	R L	RFR RFL	999.03	1008.88	25	35	32	11100	9030	1130	921

Catalog Number	Module	No. of teeth	Direction of spiral	Shape	Total Length		Face width	Height	Height to pitch line	Mounting hole dimensions			
					A	A'				B	C	D	E
● KRHGF1-500RJ ● KRHGF1-500LJ	m1	159	R L	RDR RDL	499.51	502.66	8	15	14	6	24.76	150	4
● KRHGF1.5-500RJ ● KRHGF1.5-500LJ	m1.5	106	R L	RDR RDL	499.51	504.23	12	20	18.5	8	24.76	150	4
● KRHGF2-1000RJ ● KRHGF2-1000LJ	m2	160	R L	RDR RDL	1005.31	1011.61	16	25	23	10	52.65	180	6
● KRHGF2.5-1000RJ ● KRHGF2.5-1000LJ	m2.5	128	R L	RDR RDL	1005.31	1013.19	20	30	27.5	12	52.65	180	6
● KRHGF3-1000RJ ● KRHGF3-1000LJ	m3	106	R L	RDR RDL	999.03	1008.88	25	35	32	14	49.51	180	6

- [Caution on Product Characteristics] ① For the proper helical pinions for these racks, see the Mating Gear Selection Chart on Page 192.  
 ② These gears produce axial thrust forces. Please see Page 195 for more details.
- [Precautions for Made to Order Products] ① Prices and lead times for Made to Order products require separate estimates. Contact your dealer.
- [Caution on J series] ① **Cancellation is not possible** for made-to-order products. See page 42 for lead times and allowable order quantities. See page 44 for other precautions.

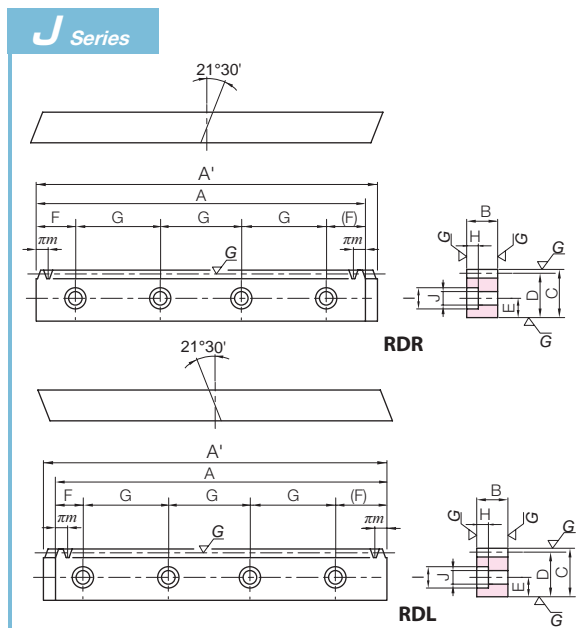
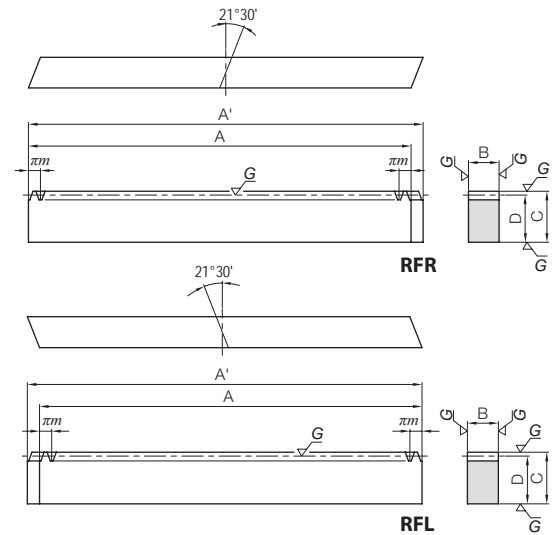
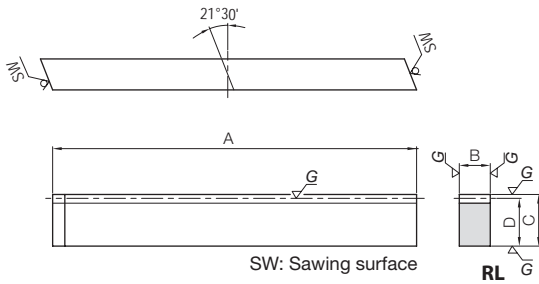

Backlash (mm)	Weight (kg)	Catalog Number
0.05~0.15	0.086	<b>KRHG1-100R</b> <b>KRHG1-100L</b>
0.05~0.15	0.18	<b>KRHG1.5-100R</b> <b>KRHG1.5-100L</b>
0.06~0.17	0.28	<b>KRHG2-100R</b> (Made to Order) <b>KRHG2-100L</b> (Made to Order)
0.06~0.17	0.43	<b>KRHG2.5-100R</b> (Made to Order) <b>KRHG2.5-100L</b> (Made to Order)
0.06~0.17	0.64	<b>KRHG3-100R</b> (Made to Order) <b>KRHG3-100L</b> (Made to Order)

Backlash (mm)	Weight (kg)	Catalog Number
0.05~0.15	0.44	<b>KRHGF1-500R</b> <b>KRHGF1-500L</b>
0.05~0.15	0.87	<b>KRHGF1.5-500R</b> <b>KRHGF1.5-500L</b>
0.06~0.17	2.90	<b>KRHGF2-1000R</b> <b>KRHGF2-1000L</b>
0.06~0.17	4.34	<b>KRHGF2.5-1000R</b> <b>KRHGF2.5-1000L</b>
0.06~0.17	6.27	<b>KRHGF3-1000R</b> <b>KRHGF3-1000L</b>

Screw size	Counterbore dimensions			Allowable force (N)		Allowable force (kgf)		Backlash (mm)	Weight (kg)	Catalog Number ● : J Series (Available-on-request)
	H	I	J	Bending strength	Surface durability	Bending strength	Surface durability			
M4	4.4	8	4.5	1180	966	121	98.5	0.05~0.15	0.43	● <b>KRHGFD1-500RJ</b> ● <b>KRHGFD1-500LJ</b>
M5	6	10	6	2670	2180	272	222	0.05~0.15	0.85	● <b>KRHGFD1.5-500RJ</b> ● <b>KRHGFD1.5-500LJ</b>
M6	7	11	7	4740	3880	483	396	0.06~0.17	2.86	● <b>KRHGFD2-1000RJ</b> ● <b>KRHGFD2-1000LJ</b>
M8	8.6	14	9	7400	6070	755	619	0.06~0.17	4.24	● <b>KRHGFD2.5-1000RJ</b> ● <b>KRHGFD2.5-1000LJ</b>
M10	10.8	17.5	11	11100	9030	1130	921	0.06~0.17	6.09	● <b>KRHGFD3-1000RJ</b> ● <b>KRHGFD3-1000LJ</b>

## Recommended Mating Pinions



## KHG Ground Helical Gears

Please see Page 196 for more details.



Spur Gears

Helical Gears

Internal Gears

Racks

CP Racks & Pinions

Miter Gears

Bevel Gears

Screw Gears

Worm Gears

Gearboxes

Other Products



Specifications	
Precision grade	KHK R 001 grade 4
Reference section of gear	Normal plane
Gear teeth	Standard full depth
Normal pressure angle	20°
Helix angle/direction	19° 31' 41" right helix
Material	S45C
Heat treatment	Gear teeth laser hardened *
Tooth hardness	55 to 65HRC
Surface treatment	Black oxide coating

\* Due to the gear teeth being laser hardened, no secondary operations can be performed on tooth areas including the bottom land (approx. 1 mm).

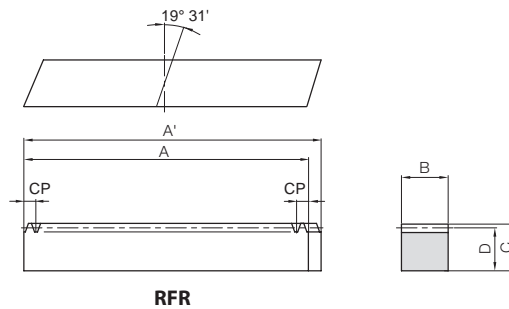

RFR

Catalog Number	Module (front pitch mm)	No. of teeth	Shape	Total Length		Face width	Height	Height to pitch line
				A	A'	B	C	D
<b>SRHEF3-1000RHL</b>	<b>m3</b> (CP10)	100	RFR	1000	1010.29	29	29	26
<b>SRHEF4-1000RHL</b>	<b>m4</b> (CP13.333)	75			1013.83	39	39	35
<b>SRHEF5-1000RHL</b>	<b>m5</b> (CP16.667)	60			1017.38	49	39	34
<b>SRHEF6-1000RHL</b>	<b>m6</b> (CP20)	50			1020.93	59	49	43

- [Caution on Product Characteristics]
- ① For the helical gear series combinations, see the Mating Gear Selection Chart on Page 192.
  - ② These gears produce axial thrust forces. Please see Page 195 for more details.
  - ③ For the assembly joining gauge, use ZST-GL on Page 268.



Allowable force (N)		Allowable force (kgf)		Backlash (mm)	Weight (kg)	Catalog Number
Bending strength	Surface durability	Bending strength	Surface durability			
7200	3540	735	361	0.15~0.39	5.91	<a href="#">SRHEF3-1000RHL</a>
13400	5800	1370	591	0.19~0.47	10.7	<a href="#">SRHEF4-1000RHL</a>
20100	8750	2050	892	0.21~0.52	13.1	<a href="#">SRHEF5-1000RHL</a>
29800	15200	3040	1550	0.23~0.57	19.9	<a href="#">SRHEF6-1000RHL</a>

## Recommended Mating Pinions



## SHE- Hardened Helical Gears

Please see Page 264 for more details.



Specifications	
Precision grade	KHK R 001 grade 5
Reference section of gear	Normal plane
Gear teeth	Standard full depth
Normal pressure angle	20°
Helix angle	15°
Material	S45C
Heat treatment	—
Tooth hardness	(less than 210HB)
Surface treatment	Black oxide coating

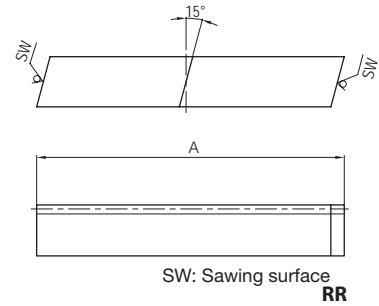

Catalog Number	Module	Effective number of teeth	Direction of spiral	Shape	Total Length	Face width	Height	Height to pitch line	Allowable force (N)		Allowable force (kgf)		Backlash (mm)	Weight (kg)
					A	B	C	D	Bending strength	Surface durability	Bending strength	Surface durability		
<b>SRH2-100R</b> <b>SRH2-100L</b>	<b>m2</b>	12	R L	RR RL	95	25	25	23	4710	1570	481	160	0.12~0.31	0.43
<b>SRH3-100R</b> <b>SRH3-100L</b>	<b>m3</b>	7	R L	RR RL	95	35	35	32	9910	3520	1010	359	0.15~0.38	0.84

Catalog Number	Module	No. of teeth	Direction of spiral	Shape	Total Length		Face width	Height	Height to pitch line	Allowable force (N)		Allowable force (kgf)	
					A	A'	B	C	D	Bending strength	Surface durability	Bending strength	Surface durability
<b>SRHF2-1000R</b> <b>SRHF2-1000L</b>	<b>m2</b>	153	R L	RFR RFL	995.24	1001.94	25	25	23	4710	1570	481	160
<b>SRHF3-1000R</b> <b>SRHF3-1000L</b>	<b>m3</b>	102	R L	RFR RFL	995.24	1004.62	35	35	32	9910	3520	1010	359

Catalog Number	Module	No. of teeth	Direction of spiral	Shape	Total Length		Face width	Height	Height to pitch line	Mounting hole dimensions				
					A	A'	B	C	D	E	F	G	No. of holes	Screw size
<b>SRHFD2-1000R</b> <b>SRHFD2-1000L</b>	<b>m2</b>	153	R L	RDR RDL	995.24	1001.94	25	25	23	10	47.62	180	6	M6
<b>SRHFD3-1000R</b> <b>SRHFD3-1000L</b>	<b>m3</b>	102	R L	RDR RDL	995.24	1004.62	35	35	32	14	47.62	180	6	M10

- [Caution on Product Characteristics] ① For the proper helical pinions for these racks, see the Mating Gear Selection Chart on Page 192.  
 ② These gears produce axial thrust forces. Please see Page 195 for more details.  
 [Caution on Secondary Operations] ① Avoid hardening racks with bolt holes, due to mounting hole deformation.

## Recommended Mating Pinions

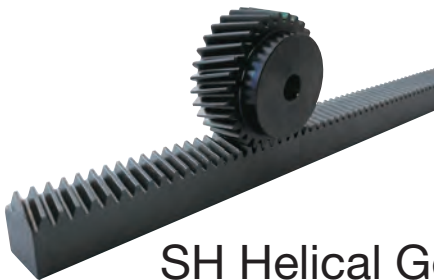

### SH Helical Gears

Please see Page 204 for more details.



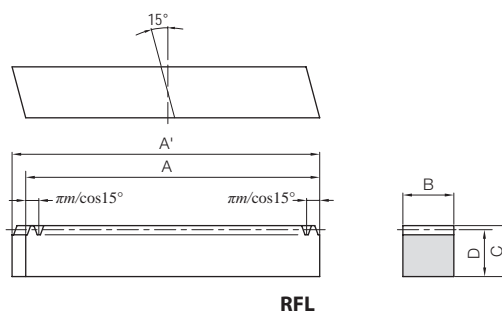
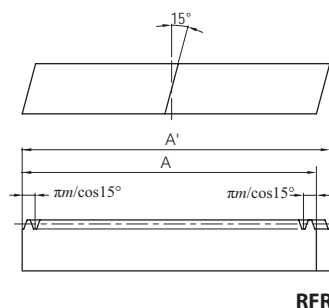
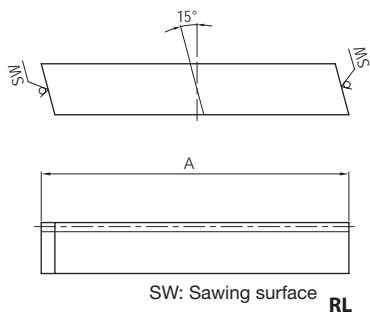

Backlash (mm)	Weight (kg)	Catalog Number
0.12~0.31	4.49	<b>SRHF2-1000R</b> <b>SRHF2-1000L</b>
0.15~0.38	8.75	<b>SRHF3-1000R</b> <b>SRHF3-1000L</b>

Counterbore dimensions			Allowable force (N)		Allowable force (kgf)		Backlash (mm)	Weight (kg)	Catalog Number
H	I	J	Bending strength	Surface durability	Bending strength	Surface durability			
7	11	7	4710	1570	481	160	0.12~0.31	4.43	<b>SRHFD2-1000R</b> <b>SRHFD2-1000L</b>
10.8	17.5	11	9910	3520	1010	359	0.15~0.38	8.52	<b>SRHFD3-1000R</b> <b>SRHFD3-1000L</b>

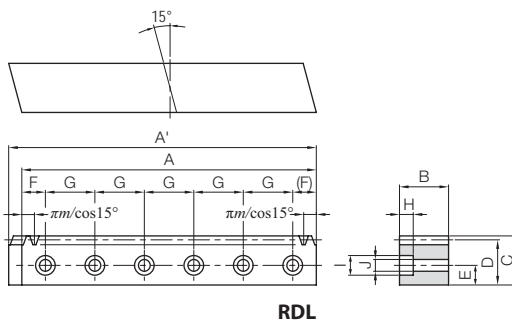
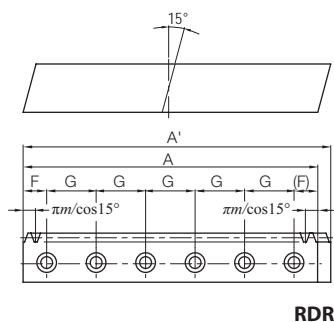

Spur Gears

Helical Gears

Internal Gears

Racks

CP Racks & Pinions

Miter Gears

Bevel Gears

Screw Gears

Worm Gears

Gearboxes

Other Products



Specifications	
Precision grade	KHK R 001 grade 4
Reference section of gear	Normal plane
Gear teeth	Standard full depth
Normal pressure angle	20°
Helix angle/direction	19° 31' 41" right helix
Material	S45C
Heat treatment	—
Tooth hardness	(less than 210HB)
Surface treatment	Black oxide coating

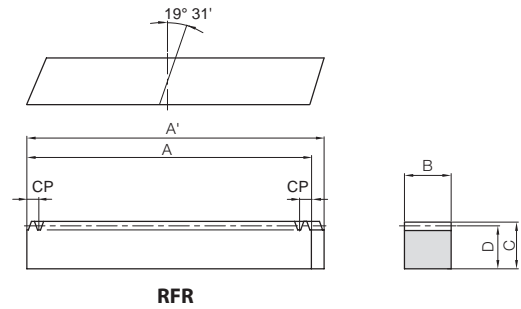

RFR

Catalog Number	Module (front pitch mm)	No. of teeth	Shape	Total Length		Face width	Height	Height to pitch line
				A	A'	B	C	D
SRHEF1.5-1000R	m1.5 (CP5)	200	RFR	1000	1006.03	17	17	15.5
SRHEF2-1000R	m2 (CP6.667)	150			1008.51	24	24	22
SRHEF3-1000R	m3 (CP10)	100			1010.29	29	29	26
SRHEF4-1000R	m4 (CP13.333)	75			1013.83	39	39	35
SRHEF5-1000R	m5 (CP16.667)	60			1017.38	49	39	34
SRHEF6-1000R	m6 (CP20)	50			1020.93	59	49	43

[Caution on Product Characteristics]

① For the proper helical pinions for these racks, see the Mating Gear Selection Chart on Page 192.

② These gears produce axial thrust forces. Please see Page 195 for more details.

③ For the assembly joining gauge, use ZST-GL on Page 268.



Specifications	
Precision grade	JIS grade N8 (JIS B1702-1: 1998)
Reference section of gear	Normal plane
Gear teeth	Standard full depth
Normal pressure angle	20°
Helix angle/direction	19° 31' 41" left helix
Material	S45C
Heat treatment	—
Tooth hardness	(less than 194HB)
Surface treatment	Black oxide coating

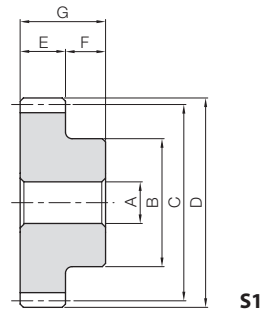

S1

**H** To order Hardened Plus, please specify **Catalog No. + H**. Example: **SHE1.5-20LH**

Catalog Number	Module (front pitch mm)	No. of teeth	Profile shift coefficient	Mounting distance	Shape	Bore	Hub dia.	Pitch dia.	Outside dia.	Face width	Hub width
						AH7	B	C	D	E	F
SHE1.5-20L	m1.5(CP5)	20	+0.390	32	S1	10	25	31.83	36	18	14
SHE1.5-25L		25	+0.404	36		12	35	39.79	44	18	14
SHE1.5-30L		30	+0.418	40		15	40	47.75	52	18	14
SHE2-18L	m2(CP6.667)	18	+0.451	42		12	30	38.20	44	25	16
SHE2-24L		24	+0.268	48		15	45	50.93	56	25	16
SHE2-30L		30	+0.085	54		18	55	63.66	68	25	16
SHE3-20L	m3(CP10)	20	+0.390	59		20	55	63.66	72	30	20
SHE3-25L		25	+0.404	67		20	70	79.58	88	30	20
SHE3-30L		30	+0.418	75		25	85	95.49	104	30	20
SHE4-18L	m4 (CP13.333)	18	+0.201	74		20	65	76.39	86	40	25
SHE4-24L		24	+0.268	87		20	90	101.86	112	40	25
SHE4-30L		30	+0.335	100		25	110	127.32	138	40	25
SHE5-18L	m5 (CP16.667)	18	+0.451	84		25	85	95.49	110	50	25
SHE5-24L		24	+0.468	100		25	110	127.32	142	50	25
SHE6-20L	m6(CP20)	20	+0.390	109		30	110	127.32	144	60	28
SHE6-25L		25	+0.404	125		30	140	159.15	176	60	28

[Caution on Product Characteristics]

① The backlash values shown in the table are the theoretical values for the backlash in the circumferential direction of SRHEF Helical Racks with the same pitch.

[Caution on Secondary Operations]

① See Page 22 for more details on Hardened Plus (H Series and HJ Series).



**ZST-GL  
Assembly Gauges**

Material: S45C  
Accuracy: KHK R 001 Grade 2  
Please see Page 268 in the Master Catalog for more details.

Allowable force (N)		Allowable force (kgf)		Backlash (mm)	Weight (kg)	Catalog Number
Bending strength	Surface durability	Bending strength	Surface durability			
2410	425	245	43.3	0.10~0.28	2.06	<b>SRHEF1.5-1000R</b>
4410	675	450	68.8	0.12~0.32	4.14	<b>SRHEF2-1000R</b>
8210	1650	837	168	0.15~0.39	5.91	<b>SRHEF3-1000R</b>
15200	2700	1550	275	0.19~0.47	10.7	<b>SRHEF4-1000R</b>
22500	4110	2300	419	0.21~0.52	13.1	<b>SRHEF5-1000R</b>
33400	7240	3410	738	0.23~0.57	19.9	<b>SRHEF6-1000R</b>

Helical Gears

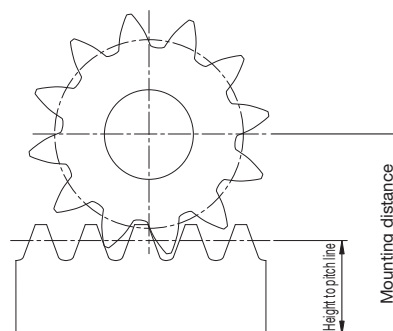
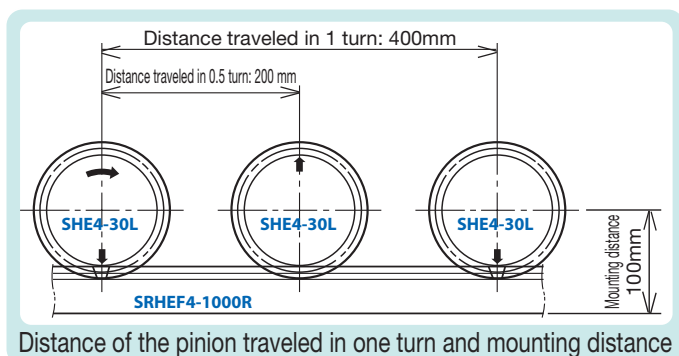

Distance of the pinion traveled in one turn and mounting distance

Mounting distance of profile helix gear and meshing rack

Total Length G	Distance traveled in one turn Distance traveled (mm)	Allowable torque						Backlash (mm)	Weight (kg)	Catalog Number	
		Bending strength		Surface durability		Surface durability					
		N·m	kgf·m	N·m	kgf·m	N·m	kgf·m				
32	100	35.6	3.63	5.89	0.60	20.1	2.05	0.10~0.28	0.16	<b>SHE1.5-20L</b>	
32	125	46.5	4.75	10.3	1.05	34.9	3.56		0.26	<b>SHE1.5-25L</b>	
32	150	57.6	5.87	16.3	1.66	54.7	5.57		0.36	<b>SHE1.5-30L</b>	
41	120	78.2	7.98	11.2	1.15	38.1	3.88	0.12~0.32	0.30	<b>SHE2-18L</b>	
41	160	107	10.9	24.4	2.48	81.3	8.29		0.56	<b>SHE2-24L</b>	
41	200	136	13.8	43.8	4.46	144	14.7		0.85	<b>SHE2-30L</b>	
50	200	238	24.2	45.7	4.66	150	15.3	0.15~0.39	1.06	<b>SHE3-20L</b>	
50	250	310	31.6	80.1	8.17	260	26.5		1.72	<b>SHE3-25L</b>	
50	300	384	39.2	127	12.9	405	41.3		2.47	<b>SHE3-30L</b>	
65	240	474	48.3	89.8	9.16	292	29.8	0.19~0.47	1.99	<b>SHE4-18L</b>	
65	320	687	70.0	183	18.6	582	59.3		3.76	<b>SHE4-24L</b>	
65	400	902	92.0	317	32.3	992	101		5.78	<b>SHE4-30L</b>	
75	300	978	99.7	171	17.4	547	55.8	0.21~0.52	3.91	<b>SHE5-18L</b>	
75	400	1380	141	354	36.1	1110	113		6.95	<b>SHE5-24L</b>	
88	400	1900	194	402	40.9	1260	128	0.23~0.57	8.05	<b>SHE6-20L</b>	
88	500	2480	253	705	71.9	2160	221		12.8	<b>SHE6-25L</b>	

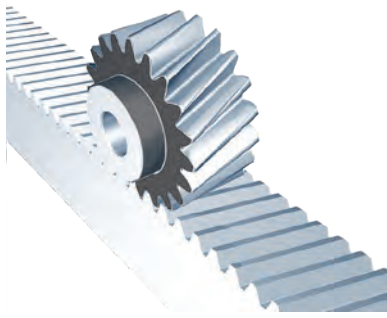

Specifications	
Precision grade	DIN3962, 3963, 3967 Grade Q6*
Reference section of gear	Normal plane
Gear teeth	Standard full depth
Pressure angle	20°
Helix angle/direction	19° 31' 41" right helix
Material	DIN C45 (JIS S45C equivalent)
Heat Treatment	Gear teeth induction hardened **
Tooth hardness	55 to 60HRC

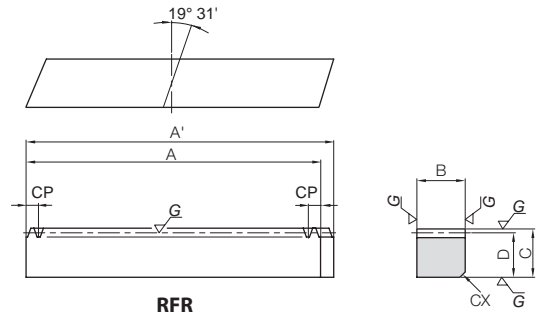

\* Equivalent to KHK R 001 Grade 2.

\*\* The precision grade of J Series products is equivalent to the value shown in the table.

\*\* Due to the gear teeth being induction hardened, no secondary operations can be performed on tooth areas including the bottom land (approx. 2 to 3 mm).

RFR

Catalog Number	Module (front pitch mm)	No. of teeth	Shape	Total Length		Face width B	Height C	Height to pitch line D	C Chamfer Amount CX	Allowable force (N)		Allowable force (kgf)		Backlash (mm)	Weight (kg)	
				A	A'					Bending strength	Surface durability	Bending strength	Surface durability			
ZST2-1000R	m2 (CP6.667)	150	RFR	1000	1008.51	24	24	22	2	4410	2140	450	219	0.06~0.14	4.13	
ZST2-2000R	m2 (CP6.667)	300		2000	2008.52	24	24	22		8210	5580	837	569		8.26	
ZST3-1000R	m3 (CP10)	100		1000	1010.29	29	29	26	3	15200	8960	1550	914		10.7	
ZST3-2000R	m3 (CP10)	200		2000	2010.29	29	29	26		22500	13300	2300	1360		21.4	
ZST4-1000R	m4 (CP13.333)	75		1000	1013.83	39	39	35	3	22500	13300	2300	1360		0.06~0.15	13.0
ZST4-2000R	m4 (CP13.333)	150		2000	2013.83	39	39	35		33400	22800	3410	2320			19.9
ZST5-1000R	m5 (CP16.667)	60	RFR	1000	1017.38	49	49	34	3	22500	13300	2300	1360	0.06~0.15	13.0	
ZST6-1000R	m6 (CP20)	50		1000	1020.93	59	59	43		33400	22800	3410	2320		19.9	

Catalog Number	Module (front pitch mm)	No. of teeth	Shape	Total Length		Face width B	Height C	Height to pitch line D	C Chamfer Amount CX	Mounting hole dimensions					
				A	A'					E	F	(F')	G	No. of holes	Screw size
ZSTD2-1000RJ	m2 (CP6.667)	150	RDR	1000	1008.51	24	24	22	2	8	71.01	53.99	125	8	M6
ZSTD2-2000RJ		300		2000	2008.52	24	24	22		9	72.79	52.21		8	
ZSTD3-1000RJ	m3 (CP10)	100		1000	1010.29	29	29	26	3	12	76.33	48.67		8	M8
ZSTD3-2000RJ		200		2000	2010.29	29	29	26		79.88	45.12	8			
ZSTD4-1000RJ	m4 (CP13.333)	75		1000	1013.83	39	39	35	3	16	83.43	41.57		8	M12
ZSTD4-2000RJ		150		2000	2013.83	39	39	35		16	83.43	41.57		8	
ZSTD5-1000RJ	m5 (CP16.667)	60	RDR	1000	1017.38	49	49	34	3	16	83.43	41.57	8	M16	
ZSTD6-1000RJ	m6 (CP20)	50		1000	1020.93	59	59	43		16	83.43	41.57	8		



Specifications	
Precision grade	JIS B 1702-1:1998 Grade N6 *
Reference section of gear	Normal plane
Gear teeth	Standard full depth
Pressure angle	20°
Helix angle/direction	19° 31' 41" left helix
Material	SCM440
Heat treatment	Thermal refined, gear teeth induction hardened **
Tooth hardness	50 to 60HRC
Surface treatment	Black oxide coated except for ground part
Shape	S1

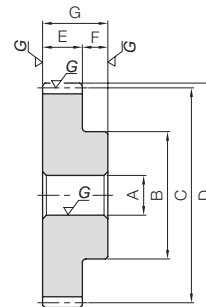

\* The precision grade of J Series products is equivalent to the value shown in the table.

\*\* Due to the gear teeth being induction hardened, no secondary operations can be performed on tooth areas including the bottom land (approx. 2 to 3 mm).

S1

Catalog Number	Module (front pitch mm)	No. of teeth	Profile shift coefficient	Mounting Distance	Bore	Hub dia.	Pitch dia.	Outside dia.	Face width	Hub width	Total length	Distance traveled in one turn	Allowable torque (N·m)		Allowable torque (kgf·m)		Backlash (mm)
					A <sub>H7</sub>	B	C	D	E	F	G	Bending strength	Surface durability	Bending strength	Surface durability		
ZSTP2-18L	m2 (CP6.667)	18	+0.451	42	12	30	38.20	44	25	16	41	120	124	71.4	12.6	7.28	0.06~0.14
ZSTP2-24L		24	+0.268	48	15	45	50.93	56					169	162	17.3	16.5	
ZSTP2-30L		30	+0.085	54	18	55	63.66	68					214	263	21.8	26.9	
ZSTP3-20L	m3 (CP10)	20	+0.390	59	20	55	63.66	72	30	20	50	200	375	275	38.3	28.0	0.06~0.14
ZSTP3-25L		25	+0.404	67	20	70	79.58	88					490	471	50.0	48.0	
ZSTP3-30L		30	+0.418	75	25	85	95.49	104					606	729	61.8	74.4	
ZSTP4-18L	m4 (CP13.333)	18	+0.201	74	20	65	76.39	86	40	25	65	240	748	530	76.3	54.0	0.06~0.15
ZSTP4-24L		24	+0.268	87	20	90	101.86	112					1080	1050	111	107	
ZSTP4-30L		30	+0.335	100	25	110	127.32	138					1420	1910	145	195	
ZSTP5-18L	m5 (CP16.667)	18	+0.451	84	25	85	95.49	110	50	25	75	300	1540	985	157	100	0.06~0.15
ZSTP5-24L		24	+0.468	100	25	110	127.32	142					2180	1980	222	202	
ZSTP6-20L	m6 (CP20)	20	+0.390	109	30	110	127.32	144	60	28	88	400	3000	2240	306	229	0.06~0.15
ZSTP6-25L		25	+0.404	125	30	140	159.15	176					3920	3850	400	392	

[Caution on Product Characteristics] ① The backlash values shown in the table are the theoretical values for the backlash in the circumferential direction of ZST Helical Racks with the same pitch.

[Caution on Secondary Operations] ① Because of the influence of hardening residual stress, avoid removing the entire boss, as it may cause the gears to deform.

PUH Lubricated Helical Gears



Please see Page 494 for more details.

J Series

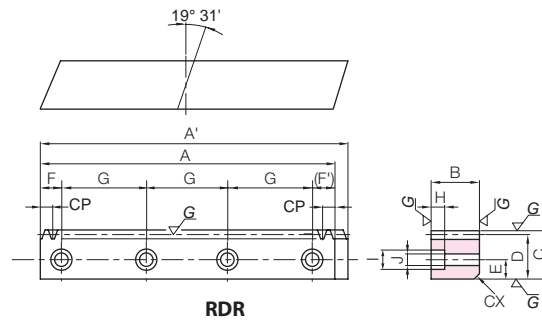

ZST-GL Assembly Gauges



Material: S45C  
Accuracy: KHK R 001 Grade 2  
Please see Page 268 in the Master Catalog for more details.

- [Caution on Product Characteristics] ① For the proper helical pinions for these racks, see the Mating Gear Selection Chart on Page 192.  
② These gears produce axial thrust forces. Please see Page 195 for more details.
- [Caution on J series] ① **Cancellation is not possible** for made-to-order products. See page 42 for lead times and allowable order quantities. See page 44 for other precautions.

Counterbore dimensions			Allowable force (N)		Allowable force (kgf)		Backlash (mm)	Weight (kg)	Catalog Number ● : J Series (Available-on-request)	
H	I	J	Bending strength	Surface durability	Bending strength	Surface durability				
7	11	7	4410	2140	450	219	0.06~0.14	4.05	● ZSTD2-1000RJ ● ZSTD2-2000RJ	
8.6	14	9	8210	5580	837	569		5.70		● ZSTD3-1000RJ ● ZSTD3-2000RJ
8.6	14	9	15200	8960	1550	914		11.4		
13	20	14	22500	13300	2300	1360	0.06~0.15	10.4	● ZSTD4-1000RJ ● ZSTD4-2000RJ	
17.5	26	18	33400	22800	3410	2320		20.9		● ZSTD5-1000RJ ● ZSTD6-1000RJ
								12.4		
								18.6		

Ground Helical Gears

J Series

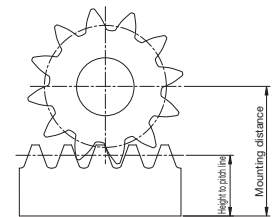
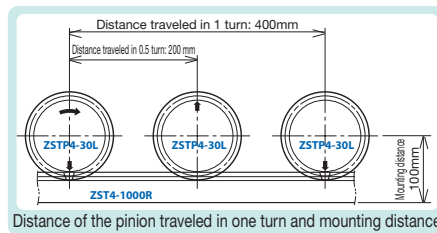
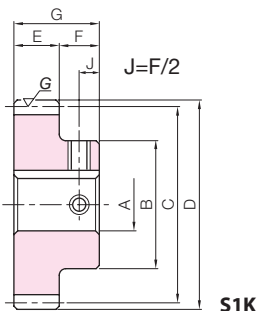

Mounting distance of profile helix gear and meshing rack

To order J Series products, please specify: **Catalog No. + J + BORE.**

Bore H7	* The product shapes of J Series items are identified by background color.																											
Keyway JS9	12	14	15	16	17	18	19	20	22	25	28	30	32	35	40	45	50	55	60	65	70	75	80					
Screw size	4x1.8	5x2.3				6x2.8				8x3.3				10x3.3		12x3.3	14x3.8		16x4.3	18x4.4		20x4.9		22x5.4				
Catalog Number	M4				M5				M6				M8		M10	M12		M16										
ZSTP2-18LJ BORE																												
ZSTP2-24LJ BORE																												
ZSTP2-30LJ BORE																												
ZSTP3-20LJ BORE																												
ZSTP3-25LJ BORE																												
ZSTP3-30LJ BORE																												
ZSTP4-18LJ BORE																												
ZSTP4-24LJ BORE																												
ZSTP4-30LJ BORE																												
ZSTP5-18LJ BORE																												
ZSTP5-24LJ BORE																												
ZSTP6-20LJ BORE																												
ZSTP6-25LJ BORE																												

[Caution on J series] ① **Cancellation is not possible** for made-to-order products. See page 42 for lead times and allowable order quantities. See page 44 for other precautions.

Spur Gears

Helical Gears

Internal Gears

Racks

CP Racks & Pinions

Miter Gears

Bevel Gears

Screw Gears

Worm Gears

Gearboxes

Other Products



Spur Gears

Helical Gears

Internal Gears

Racks

CP Racks & Pinions

Miter Gears

Bevel Gears

Screw Gears

Worm Gears

Gearboxes

Other Products



Specifications	
Precision grade	KHK R 001 grade 2
Reference section of gear	Normal plane
Gear teeth	Standard full depth
Normal pressure angle	20°
Helix angle/direction	19° 31' 41" left helix
Material	S45C
Heat treatment	—
Tooth hardness	(less than 210HB)
Surface treatment	Black oxide coating

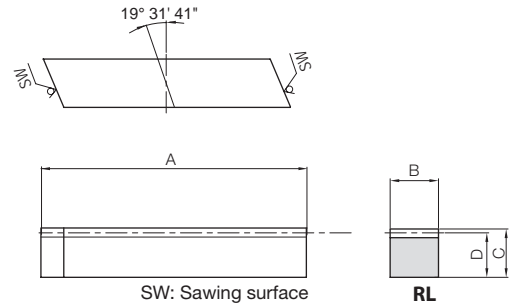

Catalog Number	Normal module (front pitch mm)	Effective No. of teeth	Shape	Total Length	Face width	Height	Height to pitch line	Weight (kg)
				A	B	C	D	
ZST1.5-GL	m1.5 (CP5)	9	RL	59	17	17	15.5	0.11
ZST2-GL	m2 (CP6.667)	7		66	25	25	23	0.26
ZST3-GL	m3 (CP10)	8		108	30	30	27	0.62
ZST4-GL	m4 (CP13.333)	6		118	40	40	36	1.17
ZST5-GL	m5 (CP16.667)	4		115	50	50	45	1.72
ZST6-GL	m6 (CP20)	3		119	60	60	54	2.49

### Points of Caution in Assembling

① ZST/ZSTD ground racks are designed to give the proper backlash when assembled using the mounting distance (tolerance of H7 to H8 required) given by the ZSTP Mating Pinion Dimension Table (Page 266). Make sure that the mounting distance stays constant for the length of the rack.

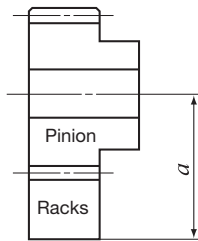

② Machined end type racks such as the ZST and ZSTD Series have pitch tolerance of -0.05 to -0.4mm at the end face. If you try to connect the racks without any space, the pitch at the connection will be too small and will cause problems. Please follow the following diagrams, "Connecting the Racks," for assembly.

③ The ZST/ZSTD type of KHK stock ground racks have four surfaces ground parallel with high precision. To maintain true angle, they should be mounted on high precision bases (within 10 μm recommended) as shown below. It is even possible to correct for the angular errors of racks by compensating the mounting base. With recent increases in the requirement for zero backlash linear drives, such accurate assembly as shown is becoming more important. If the racks are not secured properly to the base, they could shift during operation and cause unexpected problems. It is very important to insure firm mounting by the use of dowel pins or similar devices. Please see Page 221 for more details.

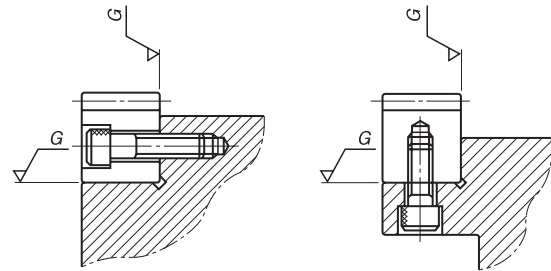

### Connecting the Racks

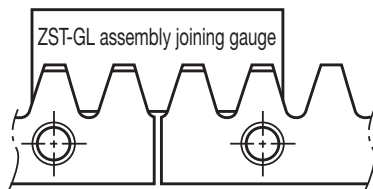

[NOTE] Please use the ZST-GL assembly gauge for the joining rack.